



Quick Installation Guide

IES-1160

Industrial Unmanaged Switch

Introduction

IES-1160 is unmanaged Ethernet switch with 16x10/100Base-(TX) ports. IES-1160 support redundant power inputs, relay output alarm, and surge protection. The wide operating temperature range from -40°C to 70°C can satisfy most of operating environments. Especially, IES-1160 features dual different redundant DC power inputs, two DC power inputs on terminal block to avoid any unexpected fails on power. Thus, IES-1160 could guarantee a non-stop operation. Therefore, the switch is one of the most reliable choice for highly-unmanaged Ethernet application.

Features

- > RJ-45 port support Auto MDI/MDI-X switching function
- > Provides Store-and-Forward switching architecture
- > Provides 3.2Gbps Back-plane (Switching Fabric)
- > Warning system by relay output
- > Rigid IP-30 housing design
- > DIN-Rail and wall mounting enabled

Power Connection Guide

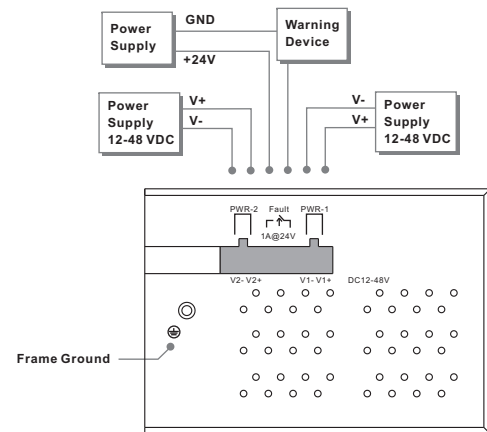

Practical Operation

IES-1160 is usually deployed for connecting several Ethernet devices, such like Ethernet I/O, IP-Camera, etc. The designs of rugged housing and wide operating temperature, range form -40 ~ 70°C, makes IES-1160 reliably in any kinds of industrial applications.

Connections of Ethernet devices

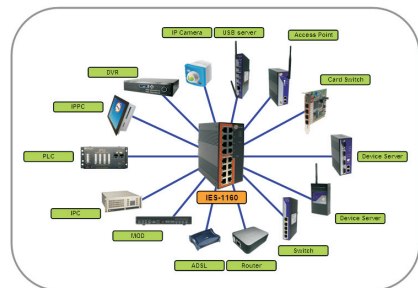

Installation

DIN-Rail Install Step

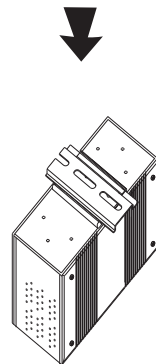
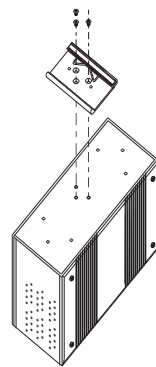

Wall-mounted Install Step

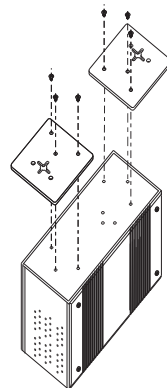

Front Panel

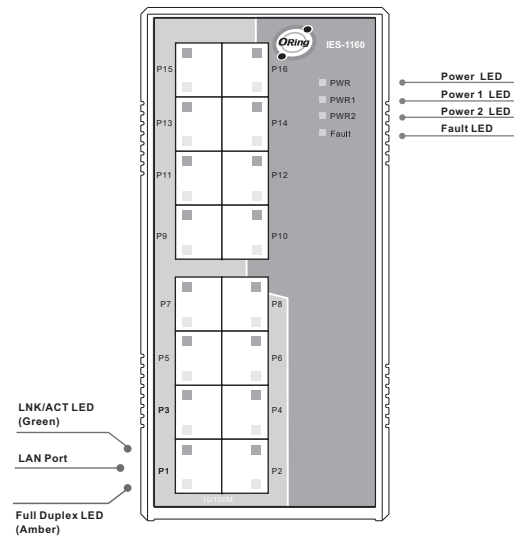

Accessory

- ① 66mm DIN-Rail kit
- ② 6-Pin Terminal block
- ③ Dust Cover
- ④ QIG
- ⑤ Wall-mounted kit

Packing list

Model Name	Model Description	Accessory
IES-1160	Industrial 16-port unmanaged Ethernet switch with 16x10/100Base-T(X)	<ul style="list-style-type: none"> ○X1, ○X1, ○X16, ○X1, ○X2

Specifications

Switch Model	IES-1160	
Physical Ports		
10/100 Base-T(X) Ports in RJ45 Auto MDI/MDIX	16	
Technology		
Ethernet Standards	IEEE 802.3 for 10Base-T, IEEE 802.3u for 100Base-T(X), IEEE 802.3x for Flow control	
MAC Table	8192 MAC addresses	
Priority Queues	4	
Processing	Store-and-Forward	
Switch Properties	Switching latency: 9 us Switching bandwidth: 3.2Gbps	
LED Indicators		
Power indicator	Green: Power LED x 3	
Fault Indicator	Amber: Indicate power failed warning	
10/100Base-T(X) RJ45 Port Indicator	Green for port Link/Act. Amber for Duplex/Collision	
Fault contact		
Relay	Relay output to carry capacity of 1A at 24VDC	
Power		
Redundant Input power	Dual DC inputs, 12-48VDC on 6-pin terminal block	
Power consumption(Typ.)	9 Watts	
Reverse polarity protection	Present	
Overload current protection	Present on terminal block	
Physical Characteristic		
Enclosure	IP-30	
Dimension (W x D x H)	74.3(W)x109.2(D)x153.6(H) mm (2.93x4.3x6.05 inch)	
Weight (g)	1060g	
Environmental		
Storage Temperature	-40 to 85°C (-40 to 185°F)	
Operating Temperature	-40 to 70°C (-40 to 158°F)	
Operating Humidity	5% to 95% Non-condensing	
Regulatory approvals		
EMI	FCC Part 15, CISPR (EN55022) class A	
EMS	EN61000-4-2 (ESD), EN61000-4-3 (RS), EN61000-4-4 (EFT), EN61000-4-5 (Surge), EN61000-4-6 (CS), EN61000-4-8, EN61000-4-11	
Shock	IEC60068-2-27	
Free Fall	IEC60068-2-32	
Vibration	IEC60068-2-6	
Safety	EN60950-1	
Warranty	5 years	



ORing Industrial Networking Corp.

Copyright© 2010 ORing
All rights reserved.



TEL: +886-2-2918-3036 Website: www.oring-networking.com
FAX: +886-2-2918-3084 E-mail: support@oring-networking.com