

Korenix JetNet 3810G Series
JetNet 3810(Gf)/ 3806G/ 3710G
Industrial Power over Ethernet GbE Switch

User's Manual

Sixth Edition, March 2012



www.korenix.com

Korenix JetNet 3810G Series

JetNet 3810(Gf)/ 3806G/ 3710G

Industrial Power over Ethernet GbE Switch

User's Manual

Copyright Notice

Copyright © 2008 Korenix Technology Co., Ltd.
All rights reserved.
Reproduction in any form or by any means without permission is prohibited.

Index

Index.....	2
1. Introduction	3
1.1 Overview	4
1.2 Product Features	5
2. Hardware Installation.....	6
2.1 Hardware Introduction.....	6
Dimensions.....	6
Front Panel	8
Bottom View	10
LED Indicators.....	10
2.2 Wiring the Power Inputs	12
2.3 Wiring the Relay Output	13
2.4 Wiring Earth Ground	14
2.5 DIP Switches	14
2.6 Wiring the Ethernet Ports	15
2.7 Wiring the Fiber Ports (only JetNet 3810Gf)	16
2.8 Connecting Powered Device (PD)	17
2.9 DIN-Rail Mounting Installation.....	18
3. Appendix	19
3.1 Product Specification	19
3.2 Revision History.....	21

1. Introduction

Korenix JetNet 3810G Series is a power over Ethernet rail switch that is specially designed for industrial or commercial applications. The following topics are covered in this chapter:

1.1 Overview

1.2 Product Features

1.1 Overview

JetNet 3810G series, Industrial Power over Ethernet (PoE) GbE Switches, are designed with 8/4 Fast Ethernet PoE ports and 2Gigabit uplink ports to ensure high-bandwidth uplink connection for wide PoE markets. This series include JetNet 3810G/ 3806G/ 3710G which are all compliant with IEEE 802.3af PoE standard to deliver maximum 15.4Watts per port. For JetNet 3810G/ 3806G model, it integrates with Korenix patented power boost technology- Input DC 12~24V boosting to 48V built-in power booster which is the best solution for the vehicle PoE applications with standard DC 48V power supply unavailable. For fiber Switch series such as JetNet 3810Gf, it combines hot-swappable SFP fiber transceiver interfaces which can meet different specifications of fiber cable for extending transmission distance.

To ensure the high quality of video data transmission, JetNet 3810G series not only provide Gigabit bandwidth uplink for large image traffic, but also support QoS to adjust the priority of data transfer. With the feature of Fault Relay, JetNet 3810G series could automatically warn administrator if any abnormal situation happens. The compact size with IP-30 rigid aluminum case allows JetNet 3810G series to be reliably operated in -25~60°C extreme environment.

1.2 Product Features

Korenix JetNet 3810(Gf)/ 3806G/ 3710G have the following features:

	JetNet 3810G	JetNet 3810Gf	JetNet 3810f	JetNet 3806G	JetNet 3710G
Features Highlight					
10/100 TX PoE port	8	8	8	4	8
10/100/1000 TX uplink port	2			2	2
Giga FX SFP		2			
100 FX SFP			2		
PoE Standard compliant: IEEE802.3af PoE	Yes	Yes	Yes	Yes	Yes
PoE Power per port	15.4W	15.4W	15.4W	15.4W	15.4W
Total PoE Power Budget	65W*	65W*	65W*	60W*	65W*
Quality of Service	Yes	Yes	Yes	Yes	Yes
Fault relay alarm	Yes	Yes	Yes	Yes	Yes
Aluminum Case Protection	IP30	IP30	IP30	IP30	IP30
Operating Temperature	-25~60°C	-25~60°C	-25~60°C	-25~60°C	-25~70°C
Power Input	12~24V power input, 48V PoE output	12~24V power input, 48V PoE output	12~24V power input, 48V PoE output	12~24V power input, 48V PoE output	48V power input, 48V PoE output

*Specifications may change without prior notice

2. Hardware Installation

2.1 Hardware Introduction

Dimensions

JetNet 3810(Gf) dimensions: 149.0(H) x 131.2(W) x 66.0(D) (with Din-rail clip)

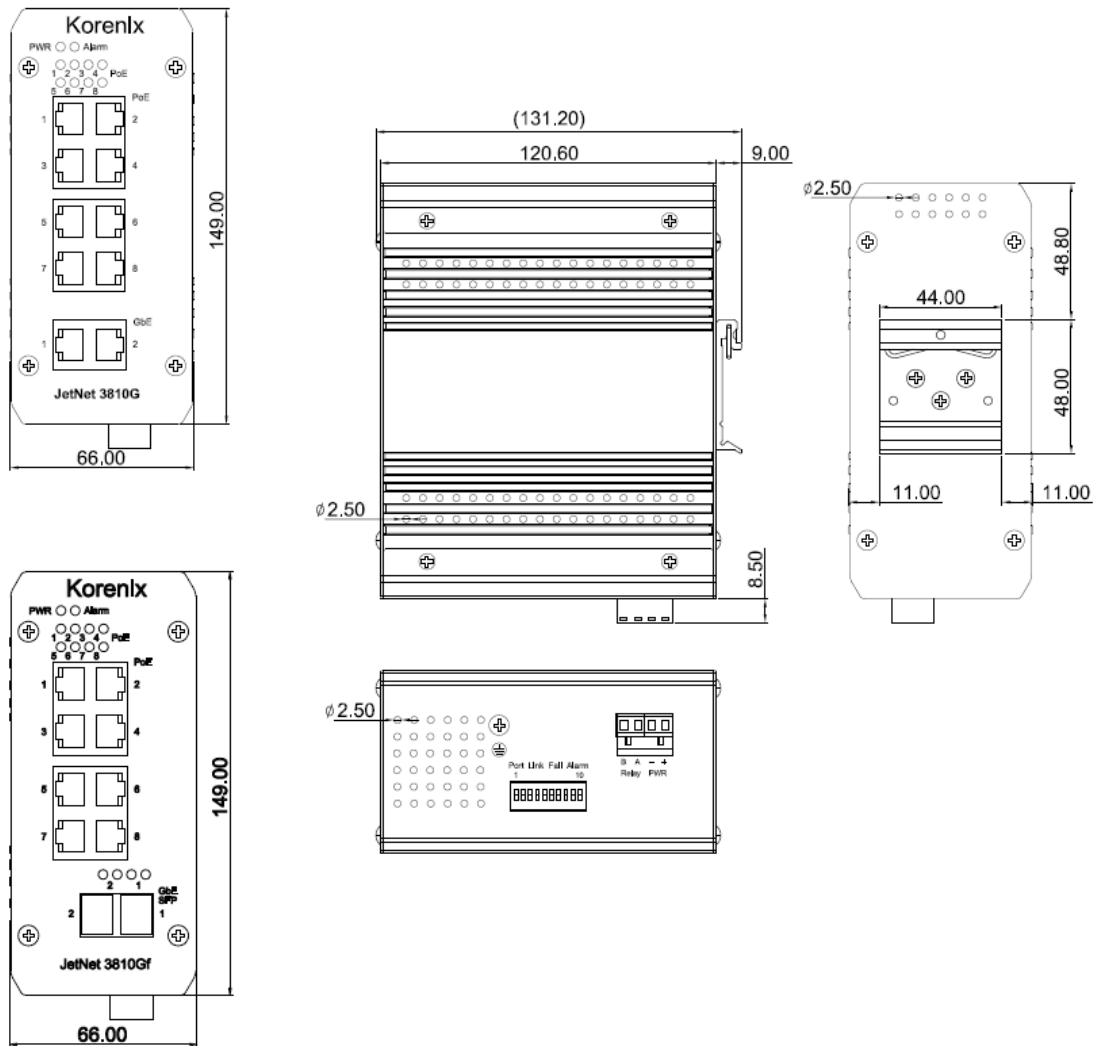

JetNet 3806G dimensions: 149.0(H) x 131.2(W) x 66.0(D) (with Din-rail clip)

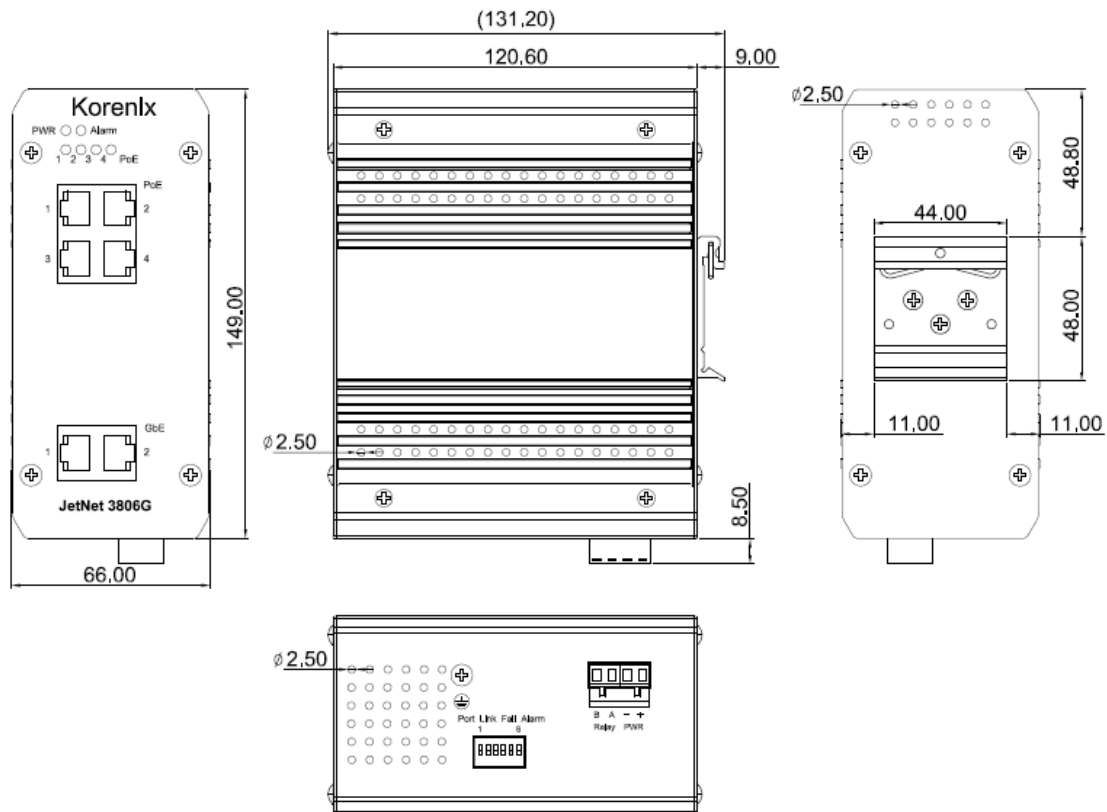

JetNet 3710G dimensions: 149.0(H) x 131.2(W) x 66.0(D) (with Din-rail clip)

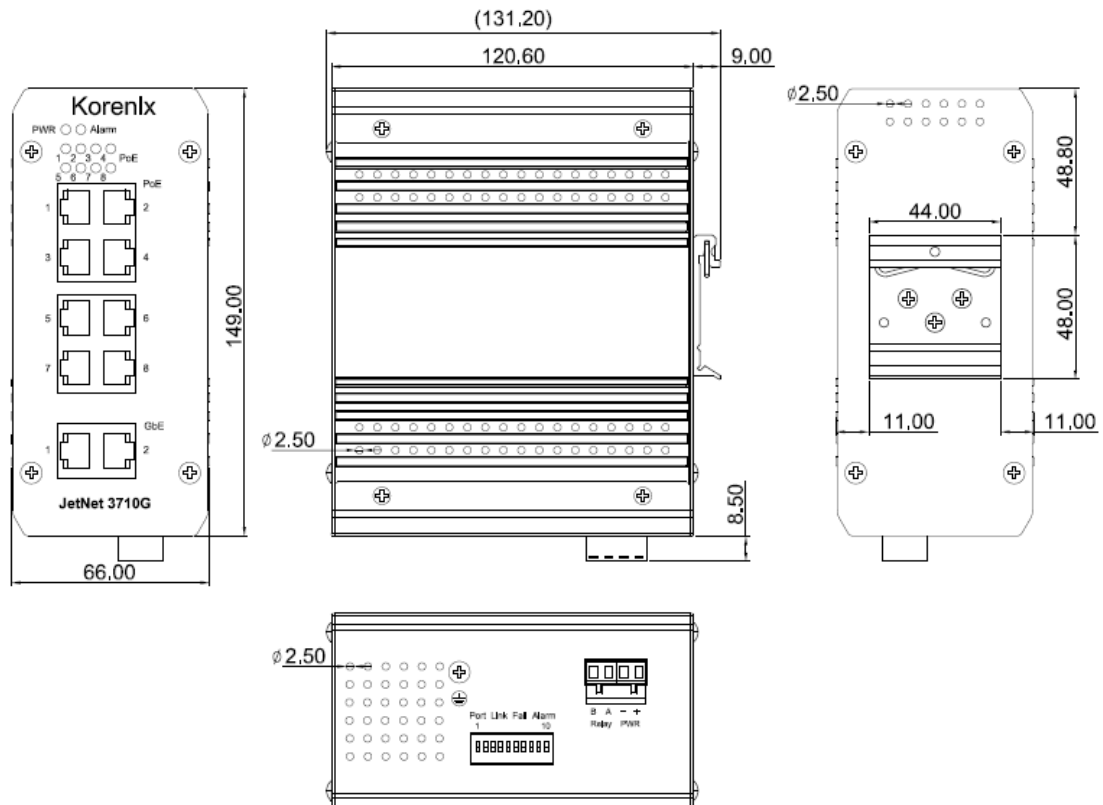

Front Panel

JetNet 3810G/ 3710G includes system power LED x1, alarm relay LED x1, PoE LED x8; and 20 LEDs for the port operating status.

JetNet 3806G includes system power LED x1, alarm relay LED x1, PoE LED x4, and 12 LEDs for the port operating status.

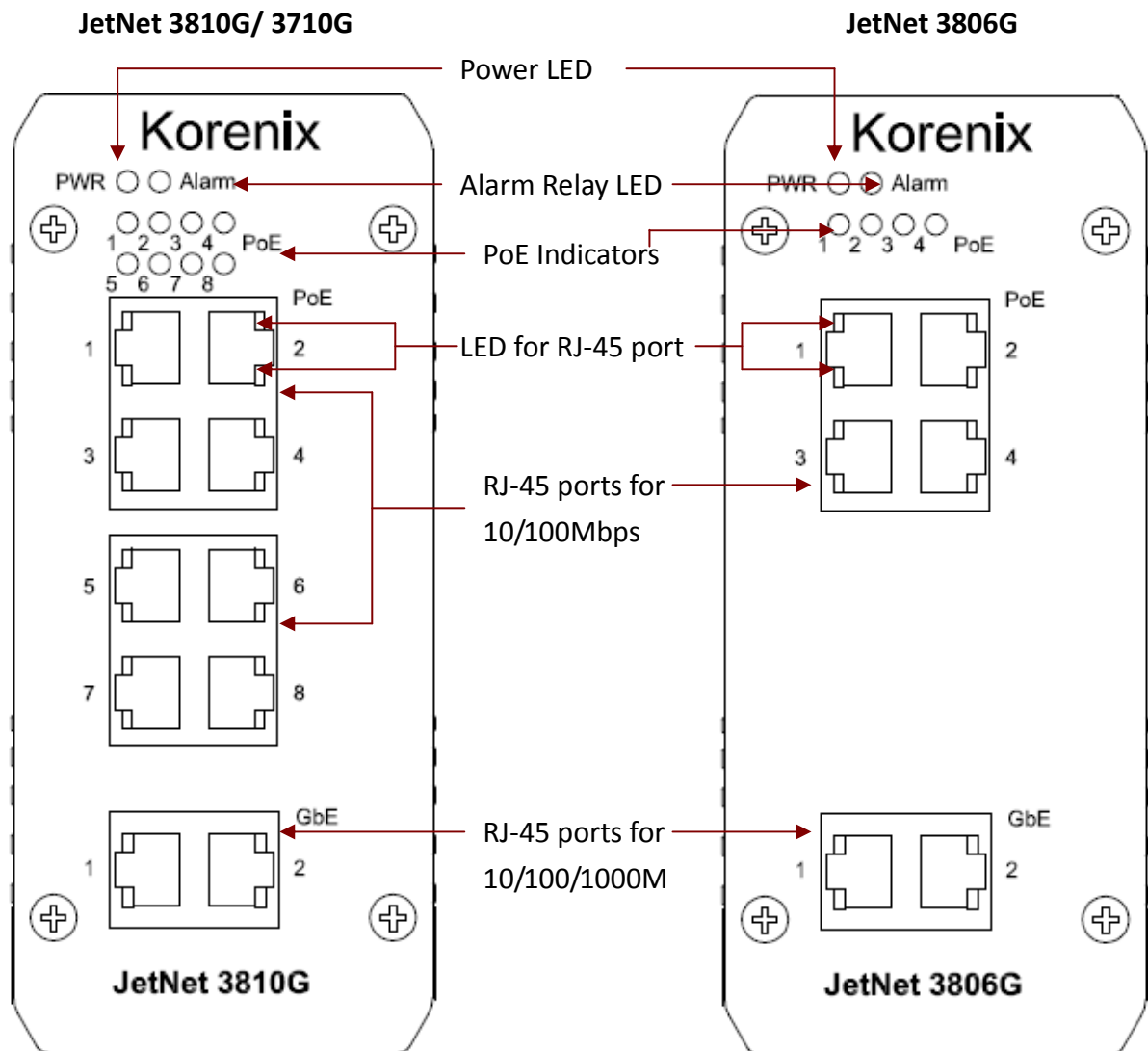

JetNet 3810Gf/ 3810f includes system power LED x1, alarm relay LED x1, PoE LED x8, 16 LEDs for RJ-45 port operating status, and 4 LEDs for SFP fiber port status.

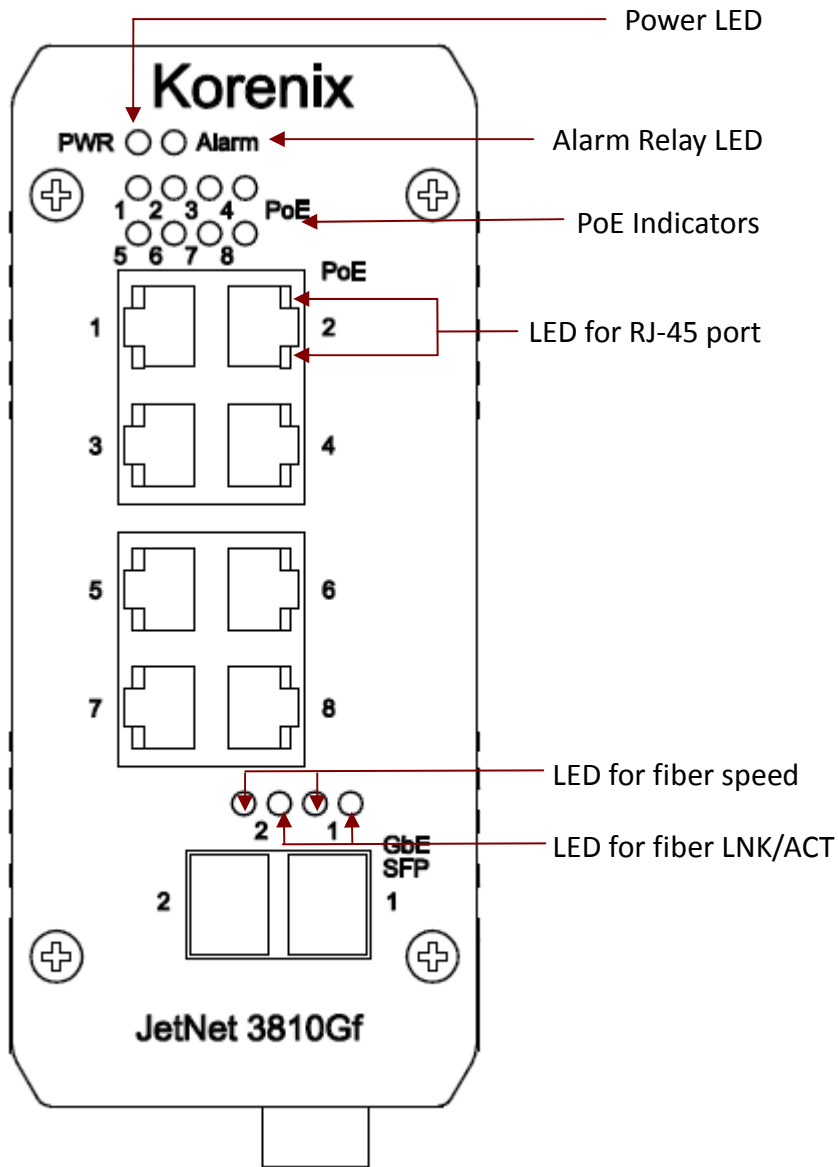

Bottom View

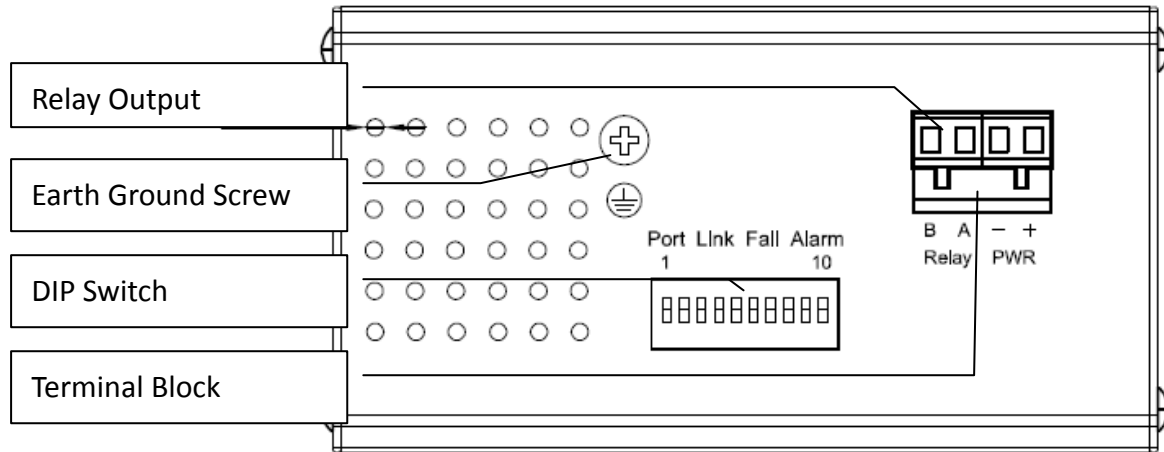

The bottom side of the JetNet 3810(Gf)/ 3710G includes one 4-pin removable terminal block connector (with 1 power input & 1 relay alarm output) and one 10-Pin DIP Switch for ports link failure alarm (6-Pin DIP Switch for JetNet 3806G). There is also an earth ground screw to prevent interference.

LED Indicators

The following table describes the function of each LED indicator.

LED	Status	Description
PWR	Green	DC-IN Power Jack is On
	Off	No Power in DC-IN
Alarm	Red	Ports link failure occur
	Off	No failure is found

PoE LED	Status	Description
PoE 1~8	Green	The port is delivering PoE power.
	Off	No PD is attached.

10/100 TX Port LED	Status	Description
LNK/ACT	Green on	RJ-45 port is attached with partner.

	Blinking	RJ-45 port is transmitting or receiving packets.
	Off	RJ-45port's link is inactive
FDX/COL	Yellow on	Link with partner on Full Duplex mode.
	Blinking	Data collision is occurred.
	off	RJ-45 port's link is inactive or link as Half Duplex mode.

For JetNet 3810G/ 3806G/ 3710G

GbE TX Port LED	Status	Description
LNK/ACT	Green on	RJ-45 port is attached with partner.
	Blinking	RJ-45 port is transmitting or receiving packets.
	Off	RJ-45port's link is inactive
Speed	Yellow Blinking	3 blinks per order – 1000Mbps
		2 blinks per order – 100Mbps
		1 blinks per order – 10Mbps
	off	RJ-45 port's link is inactive

For JetNet 3810Gf/ 3810f

GbE FX Port LED	Status	Description
LNK/ACT	Green on	Fiber port is attached with partner.
	Blinking	Fiber port is transmitting or receiving packets.
	Off	Fiber port's link is inactive
Speed	Yellow Blinking	3 blinks per order – 1000Mbps*
		2 blinks per order – 100Mbps**
	off	Fiber port's link is inactive

*NOT supported in JetNet 3810f

** 100M fiber is optional and can be supported by different settings

2.2 Wiring the Power Inputs

JetNet 3810(Gf)/3806G accepts 12~24V DC power input and boosts to 48V DC output for 802.3af standard PoE devices.

JetNet 3710G without power boosting function accepts only 48V DC power Input.

IMPORTANT: Do make sure that different models must connect to the corresponding supply voltage. Guarantee will not apply to the damage caused by wrong input power.

Note: The product intended to be supplied by LPS power supply.

1. Insert the positive and negative wires of your DC supply into the V+ and V- contacts of the terminal block connector. The acceptable wire range is 12 to 24 AWG.

JetNet 3810(Gf)/ 3806G

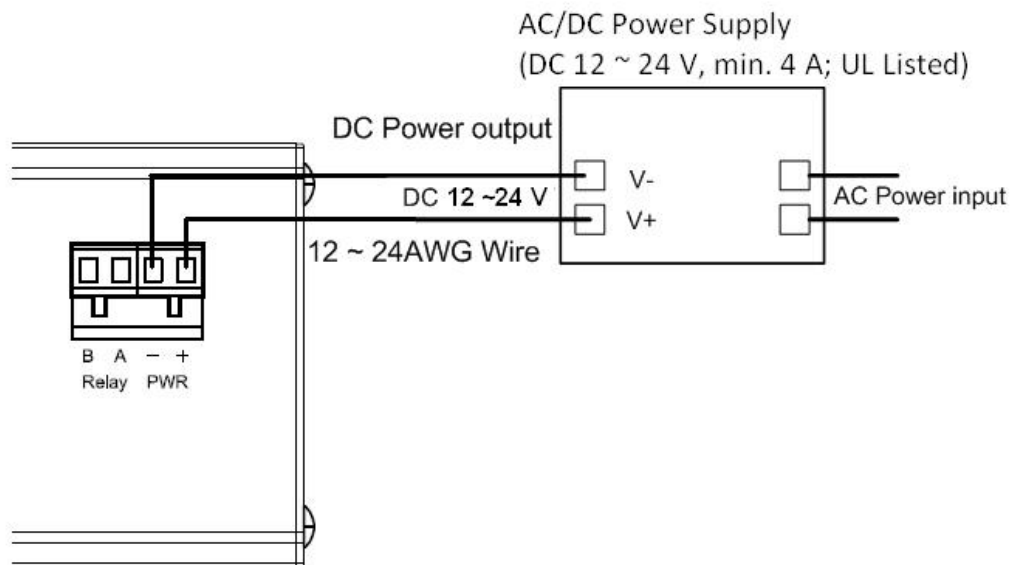

JetNet 3710G

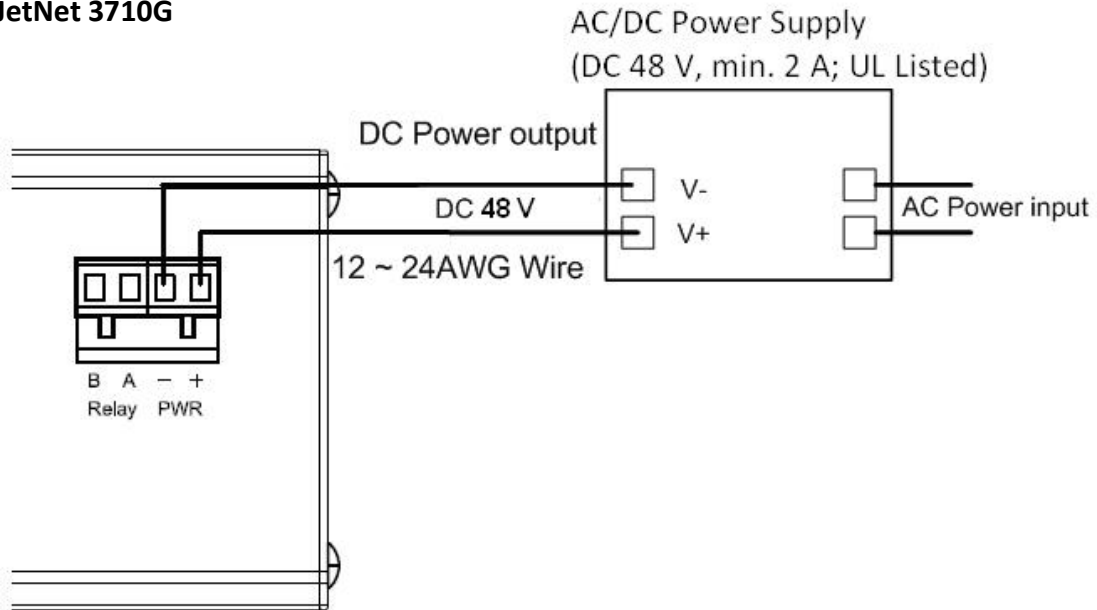

2. Tighten the terminal screws to prevent the DC wires from coming loose.

2.3 Wiring the Relay Output

JetNet 3810(Gf)/3806G/3710G provide Relay Output. The relay contacts are energized (open) for normal operation and will close under faulty condition such as Ethernet port link break. The Relay alarm can be configured by DIP Switches.

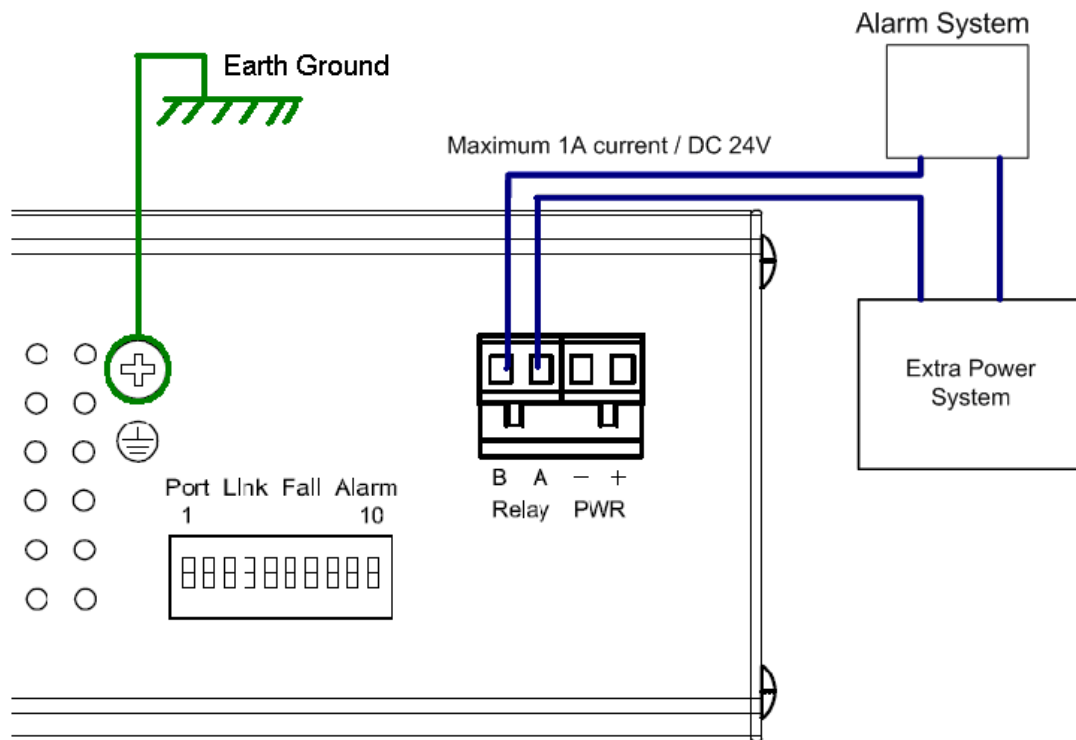

2.4 Wiring Earth Ground

To ensure the system will not be damaged by noise or electric shock, we suggest making a direct connection between the JetNet 3810(Gf)/3806G/ 3710G and earth ground to avoid system damage. (Please refer to the upside photo)

1. On the bottom of the JetNet 3810(Gf)/3806G/ 3710G, there is one earth ground screw.
2. Loosen the earth ground screw with a screwdriver
3. Tighten the screw after the earth ground wire is connected.

2.5 DIP Switches

10-Pin Dip switches are located on the bottom panel of JetNet 3810(Gf)/ 3710G for configuration purpose (6-Pin for JetNet 3806G). They are used to configure Port Alarm to corresponding TX ports.

DIP Switch number	Status	Description
DIP 1~2 JetNet 3810(Gf)/3710G/ 3806G	On	To enable GbE port break alarm at this port
	Off	To disable GbE port break alarm at this port (Default)

JetNet 3810(Gf)/3710G: DIP 3~10 JetNet 3806G: DIP 3~6	On	To enable PoE port break alarm at this port
	Off	To disable PoE port break alarm at this port (Default)

Note: Port break alarm is limited to apply on Auto-negotiation 10/100 Full-duplex device

DIP Switch number mapping to corresponding PoE port & GbE port as follow:

DIP Switch #	3	4	5	6	7	8	9	10
PoE port	1	2	3	4	5	6	7	8

For JetNet 3810G / 3710G / 3806G:

DIP Switch #	1	2
GbE port	2	1

For JetNet 3810Gf / 3810f:

DIP Switch #	1	2
GbE port	1	2

2.6 Wiring the Ethernet Ports

JetNet 3810(Gf)/ 3806G/ 3710G Industrial Gigabit PoE Switch support 8/4 RJ-45 ports with automatic MDI/MDI-X crossover, PoE Injector, and automatic 10/100Mbps data rate sensing for 10Base-T or 100Base-TX connections. Automatic MDI/MDI-X crossover allows you to connect to other switches, hubs, or workstations, without regard to using straight-through or crossover cabling. For JetNet 3810G/ 3806G/ 3710G model, the switch also provides two 10/100/1000 Base-TX uplinks.

Port 1 to port 8/4 also provides Power over Ethernet function that delivers DC 48V power through the spare pairs to power the PD.

The following figures depict the schematic diagram of straight-through and crossover cabling. Note that crossover cables simply cross-connect the transmit lines at each end to the receive lines at the opposite end.

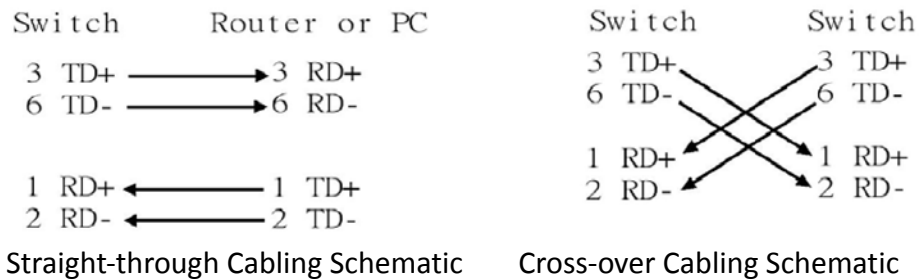

Note: that Ethernet cables use pins 1, 2, 3, and 6 of an 8-pin RJ45 connector. The signals of these pins are converted by the automatic MDI-X function, as shown in the table below:

Pin MDI-X	Signals	MDI Signals
1	RD+	TD+
2	RD-	TD-
3	TD+	RD+
6	TD-	RD-

Connect one side of an Ethernet cable into any switch port and connect the other side to your attached device. The green LNK LED will light up when the cable is correctly connected. Refer to the LED Indicators section for descriptions of each LED indicator. Always make sure that the cables between the switches and attached devices (e.g. switch, hub, or workstation) are less than 100 meters (328 feet).

2.7 Wiring the Fiber Ports (only JetNet 3810Gf)

JetNet 3810Gf equips 2 gigabit SFP fiber ports. The speed of the SFP port supports up to 1000Base-SX/LX. The SFP ports accept standard MINI GBIC SFP transceiver. But, to ensure system reliability, **Korenix recommends using the Korenix certified Gigabit SFP Transceiver**. The certificated SFP transceiver includes 1000Base-SX/LX single/multi mode ranger from 550m to 80KM. The way to connect the SFP transceiver is to plug in SFP fiber transceiver fist. Cross-connect the transmit channel at each end to the receive channel at the opposite end as illustrated in the figure below.

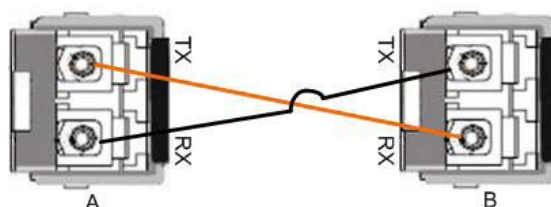

Note: This is a Class 1 Laser/LED product. Don't stare at the Laser/LED Beam.

Note: 100Base-FX SFP transceiver is optional and can be supported by different settings

Note: The unit has to use UL recognized Laser Class 1 SFP transceiver.

2.8 Connecting Powered Device (PD)

Port 1 to port 8/4 provide PoE inject function with maximum 15.4w ability to power up the powered device use the straight or cross-over Ethernet cable.

The JetNet 3810(Gf)/ 3806G/ 3710G follow the IEEE802.3af Alternative B mode connector assignment. The following table shows pin assignment of alternative A and B for the PSE (Power Source Equipment).^{PSE}

Conductor	Alternative A (MDI-X)	Alternative A (MDI)	Alternative B (All)
1	Rx & Negative Vport	Tx & Positive Vport	
2	Rx & Negative Vport	Tx & Positive Vport	
3	Tx & Positive Vport	Rx & Negative Vport	
4			Positive Vport
5			Positive Vport
6	Tx & Positive Vport	Rx & Negative Vport	
7			Negative Vport
8			Negative Vport

PIN Assignment of PSE

Be sure the twisted pair cable is bound with the standard RJ-45 pin, especially the pin 4, 5, 7 and 8.

If the RJ-45 is bound with the wrong pin number, JetNet will not recognize the PD and won't forward DC 48V power to PD, since the JetNet 3810G series switch following the Alternative B mode.

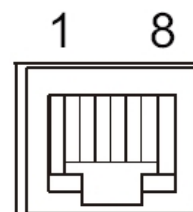

In the IEEE 802.3af standard documents, it indicates the PD should support mode A and B, and only receiver power from either mode A or mode B.

The following table shows the RJ-45 pin out for the PD.

PD Pinout		
Conductor	Mode A	Mode B
1	Positive Vport, Negative Vport	
2	Positive Vport, Negative Vport	
3	Negative Vport, Positive Vport	
4		Positive Vport,
5		Positive Vport,
6	Negative Vport, Positive Vport	
7		Negative Vport,
8		Negative Vport,

Note: This product is designed for in building installation only and is not intended to be connected to exposed (outside plant) networks.

2.9 DIN-Rail Mounting Installation

The DIN-Rail clip is already attached on the rear side of JetNet 3810(Gf)/ 3806G/ 3710G. It supports EN 50022 standard DIN Rail, in the following diagram includes the dimension of EN 55022 DIN Rail for your reference.

The DIN rail should behind the spring when install the JetNet 3810G series onto the standard DIN Rail.

Follow the steps below to mount the JetNet 3810G series on the DIN-Rail track.

1. Insert the upper end of the DIN-Rail clip into the back of the DIN-Rail track from its upper side
2. Lightly push the bottom of the DIN-Rail clip into the track.

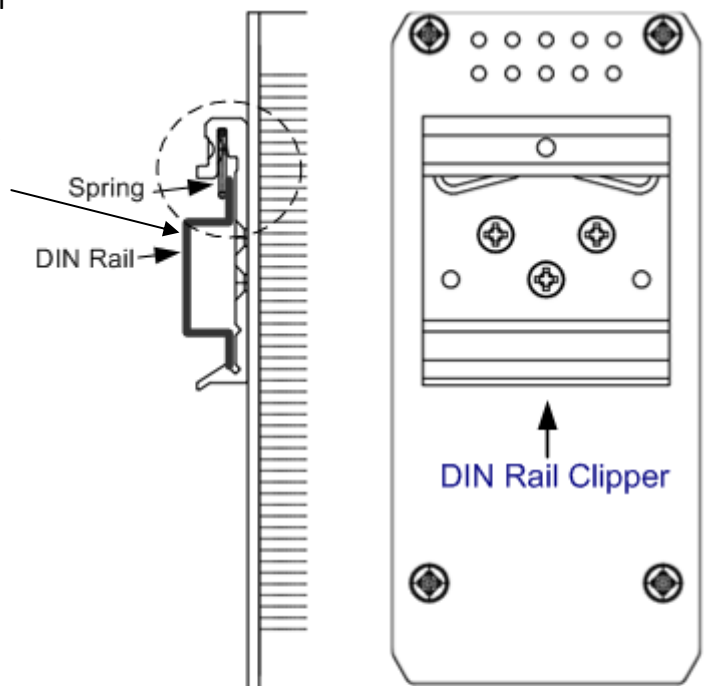

Kor
JetNet 3810(Gf)

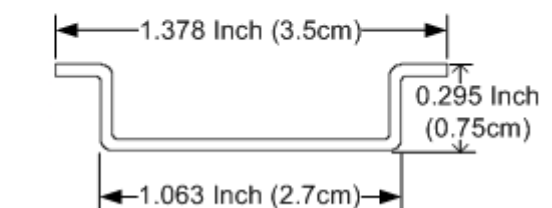

DIN EN 50022 DIN Rail Dimension

3. Check if the DIN-Rail clip is tightly attached to the track.

To remove the JetNet 3810G series from the track, reverse the steps above.

3. Appendix

3.1 Product Specification

3.2 Revision History

3.1 Product Specification

Technologies	
Standard	IEEE 802.3 10Base-T Ethernet IEEE 802.3u 100Base-T Fast Ethernet IEEE 802.3ab 1000Base-T (JetNet 3810G/ 3806G/ 3710G) IEEE 802.3z Gigabit Ethernet Fiber (only JetNet 3810Gf) IEEE802.3x Flow Control and Back-pressure (except JetNet 3810f for 100M fiber) IEEE 802.3af Power Over Ethernet IEEE 802.1p Class of Service
Performance	
Switch Technology	Store and Forward Technology with 32Gbps Switch Fabric.
System Throughput	14,880pps for 10M Ethernet, 148,800pps for 100M Fast Ethernet, 1,488,100pps for Gigabit Ethernet
Transfer packet size	64 bytes to 1522 bytes for untag and tagged frames
MAC Address	8k
Packet Buffer	1 Mbits
MTBF	Greater than 20,000 hours @ 25 °C
Interface	
Configuration	802.3af compliant PoE ports x 8 - JetNet 3810(Gf)/ 3710G x 4 - JetNet 3806G 10/100/1000Base-TX x 2 (JetNet 3810G/ 3806G/ 3710G) Gigabit/100 Base-FX SFPx 2 (JetNet 3810Gf) 100 Base-FX SFP x 2 (JetNet 3810f) Auto MDI/MDI-X, Auto Negotiation

Cables	10Base-T: 2-pair UTP/STP Cat. 3, 4, 5 cable (100m) 100 Base-TX: 2/4-pair UTP/STP Cat. 5 cable (100m) 1000 Base-T: 4-pair UTP/STP Cat. 5 cable (100m)
Diagnostic LED	Power (Green) x1 Fault alarm (Red) x1 PoE (Green) x8 - JetNet 3810(Gf)/ 3710G x4 - JetNet 3806G Link/Activity(Green) x8 - JetNet 3810(Gf)/ 3710G X4 - JetNet 3806G Full duplex/Collision (Yellow) x8 - JetNet 3810(Gf)/ 3710G x4 - JetNet 3806G JetNet 3810G/ 3806G/ 3710G: Gigabit Copper: Link/Activity(Green) x2 Gigabit Copper: Speed (Yellow) x2 JetNet 3810Gf: Gigabit fiber: Link/Activity(Green) x2 Gigabit fiber: Speed (Yellow) x2 JetNet 3810f: Fiber: Link/Activity(Green) x2 Fiber: Speed(Yellow) x2
Relay Alarm	Dry Relay output with 1A@24V ability
POE technology	Alternative B
Power Requirements	
Power	12~24V DC input voltage –JetNet 3810(Gf)/ 3806G 48V DC input voltage - JetNet 3710G Isolated 3.3V system power
Power Consumption*	JetNet 3810(Gf)/ 3710G: 30 Watt without PoE loading 95 Watt with full PoE loading JetNet 3806G: 25 Watt without PoE loading 80 Watt with full PoE loading
Mechanical	
Construction	Rugged Aluminum Alloy Chassis, IP30 protection
Mounting	DIN-Rail mount
Dimension	66(W) x 149(H) x 131.2(D) mm (with Din-rail clip)
Net weight	1.05kg

Environment

Operating Temp	JetNet 3810(Gf)/ 3806G -13 ~ 140°F(-25 ~ 60°C), 5 to 95% RH
	JetNet 3710G -13 ~ 158°F(-25 ~ 70°C), 5 to 95% RH
Storage Temp	-40 ~ 176°F(-40 ~ 80°C), 5 to 95% RH
Railway**	EN50155
EMC	EMI: FCC class A, CE/EN55022 Class A EMC: EN61000-4-2, EN61000-4-3, EN61000-4-4, EN61000-4-5, EN61000-4-6, EN61000-4-8, EN61000-4-11 Shock: IEC60068-2-27 (50g peak acceleration) Vibration: IEC60068-2-6 (5g/ 5~500Hz/random operation)
Warranty	5 years

*Specifications may change without prior notice
**pending

3.2 Revision History

Edition	Date	Modifications
V0.1	06/30/2010	New edition
V0.2	10/22/2010	Add JetNet 3810Gf
V0.3	02/11/2011	Add port alarm note
V0.6	03/05/2012	1. Add JetNet 3810f 2. Modifying DIP switches