

ADP-L2T

User's Manual

Edition 1.3



Copyright

Copyright 2008 all rights reserved. This document is copyrighted and all rights are reserved. The information in this document is subject to change without prior notice to make improvements to the products.

This document contains proprietary information and protected by copyright. No part of this document may be reproduced, copied, or translated in any form or any means without prior written permission of the manufacturer.

All trademarks and/or registered trademarks contains in this document are property of their respective owners.

Disclaimer

The company shall not be liable for any incidental or consequential damages resulting from the performance or use of this product.

The company does not issue a warranty of any kind, express or implied, including without limitation implied warranties of merchantability or fitness for a particular purpose.

The company has the right to revise the manual or include changes in the specifications of the product described within it at any time without notice and without obligation to notify any person of such revision or changes.

Trademark

All trademarks are the property of their respective holders.

Any questions please visit our website at <http://www.commell.com.tw>.

Packing List:

Hardware:

ADP-L2T adapter x1

Cable Kit:



Cable x 1

Product Specification

General Specification	
Panel	For 18-bit TTL LCD Panel
Dimensions (W x D)	31.50mm x 19.45mm
Temperature	Operating within 0~60 centigrade
Ordering Code	
ADP-L2T	LVDS to TTL adapter for 18bit LCD with Hirose DF13-40DP-1.25

Component Placement

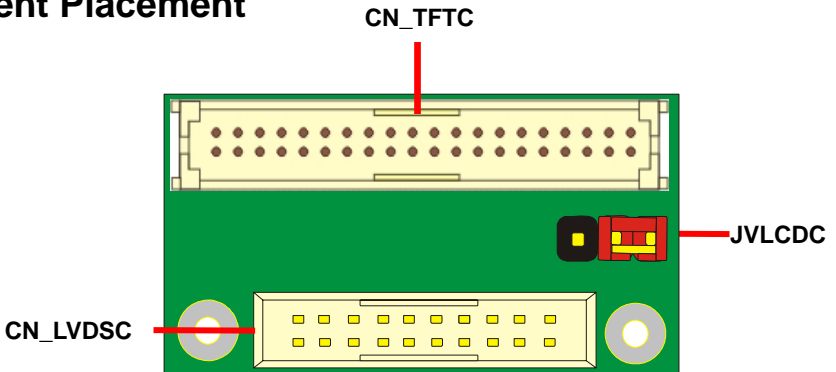

Mechanical Drawing

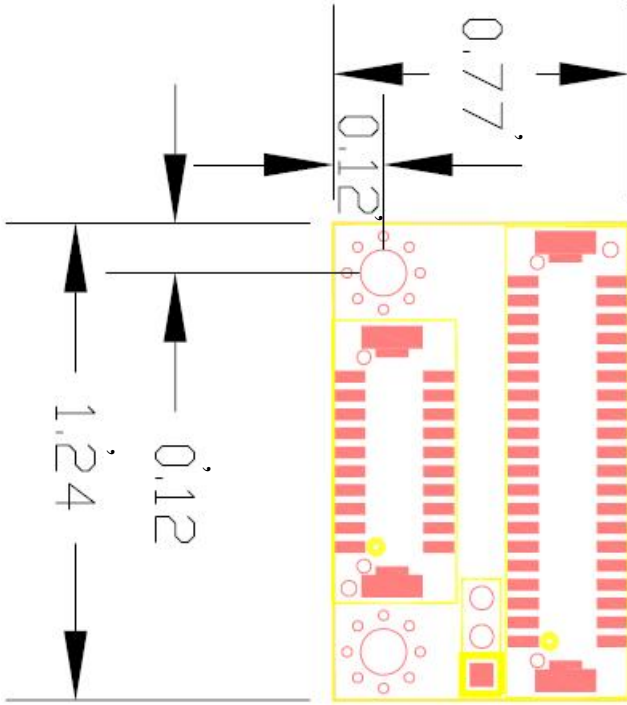

Connector Reference

Connector: JVLDCD

Type: 3-pin Power select Header

Pin	Description
1-2	VCC3 (3.3V)
2-3	VCC (5V)
Default: 1-2	

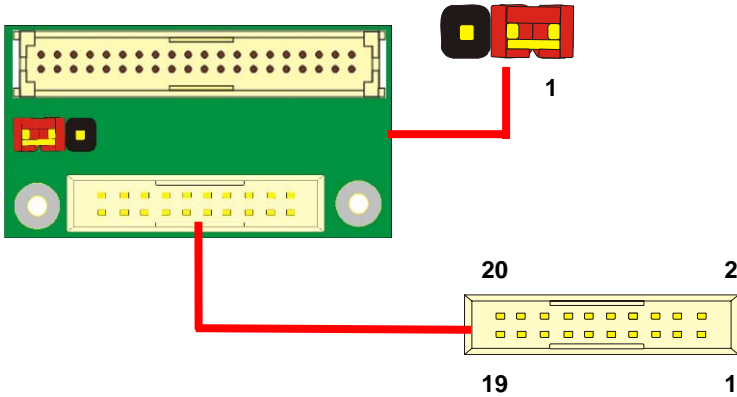

Connector: CN_LVDSC

Type: onboard 20-pin connector for LVDS connector

Connector model: **HIROSE DF13-20S**

Pin	Signal	Pin	Signal
1	LCDVCC	2	LCDVCC
3	GND	4	GND
5	TX0-	6	TX0+
7	GND	8	TX1-
9	TX1+	10	GND
11	TX2-	12	TX2+
13	GND	14	TXC-
15	TXC+	16	GND
17	N/C	18	N/C
19	GND	20	GND

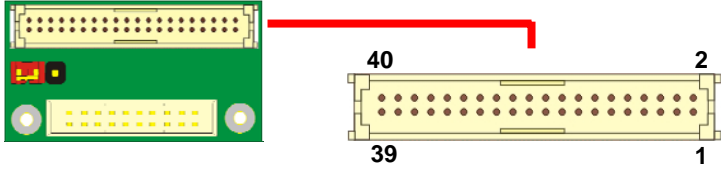

Connector: CN_TFTC

Type: onboard 40-pin connector for LVDS connector

Connector model: **HIROSE DF13-40S**

Pin	Signal	Pin	Signal
1	N/C	2	N/C
3	GND	4	GND
5	TVCC	6	TVCC
7	GND	8	GND
9	N/C	10	N/C
11	PD2 (B0)	12	PD3 (B1)
13	PD4 (B2)	14	PD5 (B3)
15	PD6 (B4)	16	PD7 (B5)
17	N/C	18	N/C
19	PD10 (G0)	20	PD11 (G1)
21	PD12 (G2)	22	PD13 (G3)
23	PD14 (G4)	24	PD15 (G5)
25	N/C	26	N/C
27	PD18 (R0)	28	PD19 (R1)
29	PD20 (R2)	30	PD21 (R3)
31	PD22 (R4)	32	PD23 (R5)
33	N/C	34	N/C
35	DCLK	36	V sync
37	DE (RM)	38	H sync
39	GND	40	GND

ADP-L2T User's Manual

To setup the LCD, you need the component below:

1. A panel with LVDS interfaces.
2. An inverter for panel's backlight power.
3. A LCD cable and an inverter cable.

For the cables, please follow the pin assignment of the connector to make a cable, because every panel has its own pin assignment, so we do not provide a standard cable; please find a local cable manufacture to make cables.

LCD Installation Guide:

1. Preparing the motherboard (LV-67B), LCD panel and the backlight inverter.

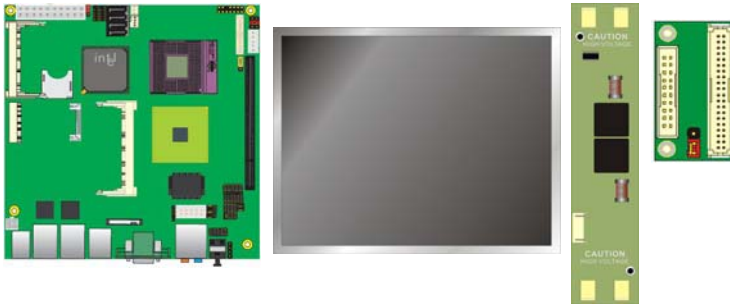

2. Please set the jumper **JVLCD** to +5V
3. You would need a LVDS type cable.



4. To connect all of the devices well.

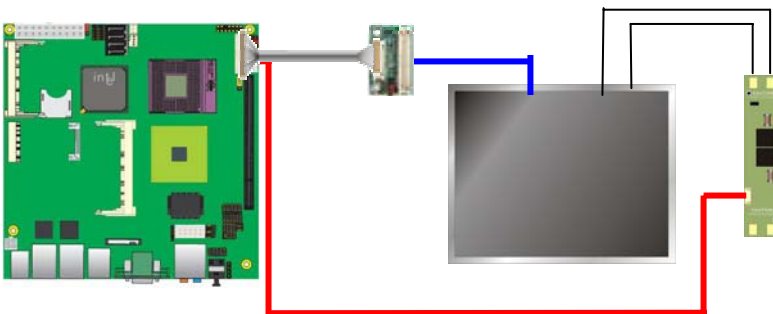

Contact Information

Any advice or comment about our products and service, or anything we can help you please don't hesitate to contact with us. We will do our best to support you for your products, projects and business.

Taiwan Commate Computer Inc.

Address	19F., No.94, Sec. 1, Xintai 5th Rd., Xizhi Dist., New Taipei City 22102, Taiwan (R.O.C.)
TEL	+886-2-26963909
FAX	+886-2-26963911
Website	http://www.commell.com.tw
E-Mail	info@commell.com.tw (General Information) tech@commell.com.tw (Technical Support)
Facebook	https://www.facebook.com/pages/Taiwan-Commate-Computer-Inc/547993955271899
Twitter	https://twitter.com/Taiwan_Commate

Commell is the trademark of Taiwan Commate Computer INC.