

I-7000 and M-7000 DIO User Manual

Warranty

All products manufactured by ICP DAS are under warranty regarding defective materials for a period of one year from the date of delivery to the original purchaser.

Warning

ICP DAS assumes no liability for damages resulting from the use of this product. ICP DAS reserves the right to change this manual at any time without notification. The information furnished by ICP DAS is believed to be accurate and reliable. However, no responsibility is assumed by ICP DAS for its use, or for any infringements of patents or other rights of third parties resulting from its use.

Copyright

Copyright 1999 - 2011 ICP DAS. All rights reserved.

Trademark

The names used for identification only may be registered trademarks of their respective companies.

Date: 2011/10/7

Table of Contents

| | |
|---|----|
| 1. Introduction | 6 |
| 1.1 More Information | 7 |
| 1.2 Terminal Assignment | 8 |
| 1.3 Specifications | 26 |
| 1.4 Block Diagrams | 32 |
| 1.4.1 Block Diagram for the I-7041/41D, I-7041P/41PD, M-7041/41D and M-7041P/41PD | 32 |
| 1.4.2 Block Diagram for the I-7042/42D | 32 |
| 1.4.3 Block Diagram for the I-7043/43D | 33 |
| 1.4.4 Block Diagram for the I-7044/44D | 33 |
| 1.4.5 Block Diagram for the I-7045/45D and M-7045/45D | 34 |
| 1.4.6 Block Diagram for the I-7045-NPN/45D-NPN and M-7045-NPN/45D-NPN | 34 |
| 1.4.7 Block Diagram for the I-7050/50D and M-7050/50D | 35 |
| 1.4.8 Block Diagram for the I-7050A/50AD | 35 |
| 1.4.9 Block Diagram for the I-7051/51D and M-7051/51D | 36 |
| 1.4.10 Block Diagram for the I-7052/52D and M-7052/52D | 36 |
| 1.4.11 Block Diagram for the I-7053_FG/53D_FG and M-7053/53D | 37 |
| 1.4.12 Block Diagram for the I-7055/55D and M-7055/55D | 37 |
| 1.4.13 Block Diagram for the I-7055-NPN/55D-NPN and M-7055-NPN/55D-NPN | 38 |
| 1.4.14 Block Diagram for the I-7058/58D and M-7058/58D | 38 |
| 1.4.15 Block Diagram for the I-7059/59D and M-7059/59D | 39 |
| 1.4.16 Block Diagram for the I-7060/60D, M-7060/60D, and M-7060P | 39 |
| 1.4.17 Block Diagram for the I-7061/61D and M-7061/61D | 40 |
| 1.4.18 Block Diagram for the I-7063/63D | 40 |
| 1.4.19 Block Diagram for the I-7063A/63AD | 41 |
| 1.4.20 Block Diagram for the I-7063B/63BD | 41 |
| 1.4.21 Block Diagram for the I-7065/65D | 42 |
| 1.4.22 Block Diagram for the I-7065A/65AD | 42 |
| 1.4.23 Block Diagram for the I-7065B/65BD | 43 |
| 1.4.24 Block Diagram for the I-7066/66D | 43 |
| 1.4.25 Block Diagram for the I-7067/67D and M-7067/67D | 44 |

| | |
|---|----|
| 1.5 Dimensions..... | 45 |
| 1.5.1 Modules without Frame Ground | 45 |
| 1.5.2 Modules with Frame Ground | 46 |
| 1.6 Wiring | 47 |
| 1.6.1 I-7041/41D, I-7041P/41PD, M-7041/41D and M-7041P/41PD wiring..... | 47 |
| 1.6.2 I-7042/42D wiring..... | 47 |
| 1.6.3 I-7043/43D wiring..... | 47 |
| 1.6.4 I-7044/44D wiring..... | 48 |
| 1.6.5 I-7045/45D and M-7045/45D wiring | 48 |
| 1.6.6 I-7045-NPN, I-7045D-NPN, M-7045-NPN and M-7045D-NPN wiring | 49 |
| 1.6.7 I-7050/50D and M-7050/50D wiring | 49 |
| 1.6.8 I-7050A/50AD wiring | 50 |
| 1.6.9 I-7051/51D and M-7051/51D wiring | 50 |
| 1.6.10 I-7052/52D and M-7052/52D wiring | 50 |
| 1.6.11 I-7053_FG/53D_FG and M-7053/53D wiring..... | 51 |
| 1.6.12 I-7055/55D and M-7055/55D wiring | 51 |
| 1.6.13 I-7055-NPN, I-7055D-NPN, M-7055-NPN and M-7055D-NPN wiring | 52 |
| 1.6.14 I-7058/58D, I-7059/59D, M-7058/58D and M-7059/59D wiring | 52 |
| 1.6.15 I-7060/60D and M-7060/60D wiring | 53 |
| 1.6.16 M-7060P wiring | 54 |
| 1.6.17 I-7061/61D and M-7061/61D wiring | 54 |
| 1.6.18 I-7063/63D, I-7063A/63AD, I-7063B/63BD, I-7065/65D, I-7065A/65AD and I-7065B/65BD wiring | 55 |
| 1.6.19 I-7066/66D, I-7067/67D and M-7067/67D wiring..... | 55 |
| 1.6.20 Wiring Recommendations..... | 55 |
| 1.7 Jumper Setting..... | 56 |
| 1.8 Quick Start | 57 |
| 1.9 Default Settings | 59 |
| 1.10 Configuration Tables..... | 60 |
| 1.11 DIO Active States | 63 |
| 1.12 M-7000 Notes..... | 64 |
| 1.12.1 Protocol Switching | 64 |
| 1.12.2 INIT Mode | 65 |
| 1.13 Mounting | 66 |

| | |
|---------------------------------|-----|
| 1.13.1 Din-Rail Mounting | 66 |
| 1.13.2 Piggyback Mounting | 68 |
| 1.13.3 Wall Mounting | 69 |
| 1.14 Technical Support | 70 |
| 2. DCON Protocol | 71 |
| 2.1 %AANNTTCCFF | 74 |
| 2.2 #** | 77 |
| 2.3 #AA00(Data)..... | 78 |
| 2.4 #AA0A(Data)..... | 80 |
| 2.5 #AA0B(Data)..... | 82 |
| 2.6 #AA1cDD | 84 |
| 2.7 #AAAcDD..... | 86 |
| 2.8 #AABcDD..... | 88 |
| 2.9 #AAN | 90 |
| 2.10 \$AA2 | 92 |
| 2.11 \$AA4 | 94 |
| 2.12 \$AA5 | 96 |
| 2.13 \$AA6 | 98 |
| 2.14 \$AAC | 100 |
| 2.15 \$AACN | 102 |
| 2.16 \$AAF..... | 104 |
| 2.17 \$AALS | 105 |
| 2.18 \$AAM | 107 |
| 2.19 \$AAP..... | 108 |
| 2.20 \$AAPN..... | 110 |
| 2.21 @AA | 112 |
| 2.22 @AA(Data)..... | 114 |
| 2.23 ~AAO(Name)..... | 116 |
| 2.24 ~**..... | 118 |
| 2.25 ~AA0..... | 119 |
| 2.26 ~AA1..... | 121 |
| 2.27 ~AA2..... | 123 |
| 2.28 ~AA3EVV..... | 125 |
| 2.29 ~AA4V | 127 |
| 2.30 ~AA5V | 129 |
| 2.31 ~AAD..... | 131 |
| 2.32 ~AADVV | 133 |
| 3. Modbus RTU Protocol | 135 |

| | |
|---|-----|
| 3.1 01 (0x01) Read Coils..... | 136 |
| 3.2 02 (0x02) Read Discrete Inputs..... | 139 |
| 3.3 03 (0x03) Read Multiple Registers | 141 |
| 3.4 04 (0x04) Read Multiple Input Registers..... | 143 |
| 3.5 05 (0x05) Write Single Coils | 145 |
| 3.6 15 (0x0F) Write Multiple Coils..... | 148 |
| 3.7 70 (0x46) Read/Write Module Settings..... | 150 |
| 3.7.1 Sub-function 00 (0x00) Read module name..... | 151 |
| 3.7.2 Sub-function 04 (0x04) Set module address | 152 |
| 3.7.3 Sub-function 05 (0x05) Read communication settings | 153 |
| 3.7.4 Sub-function 06 (0x06) Set communication settings . | 154 |
| 3.7.5 Sub-function 32 (0x20) Read firmware version..... | 156 |
| 3.7.6 Sub-function 33 (0x21) Set digital input counter trigger edge | 157 |
| 3.7.7 Sub-function 34 (0x22) Read digital input counter trigger edge value | 158 |
| 3.7.8 Sub-function 39 (0x27) Set the power-on value..... | 159 |
| 3.7.9 Sub-function 40 (0x28) Read the power-on value | 160 |
| 3.7.10 Sub-function 41 (0x29) Set DI/O active states..... | 161 |
| 3.7.11 Sub-function 42 (0x2A) Read DI/O active states..... | 163 |
| 3.8 Modbus Address Mapping | 164 |
| 4. Troubleshooting | 165 |
| 4.1 Communicating with the module | 166 |
| A. Appendix | 167 |
| A.1 INIT Mode..... | 167 |
| A.2 Dual Watchdog Operation..... | 169 |
| A.3 Frame Ground | 170 |
| A.4 Node Information Area | 172 |
| A.5 Reset Status | 173 |
| A.6 Safe Value and Power-on Value of Digital Output..... | 174 |
| A.7 Latched Digital Input..... | 175 |
| A.8 DN Module..... | 176 |
| A.8.1 DN-SSR4..... | 177 |
| A.8.2 DN-PR4 | 178 |
| A.8.3 RM-104, RM-108, and RM-116..... | 179 |
| A.8.4 RM-204, RM-208, RM-216 | 180 |

1. Introduction

The I-7000 series is a family of network data acquisition and control modules, providing analog-to-digital, digital-to-analog, digital input/output, timer/counter and other functions. The modules can be remotely controlled using a set of commands, which we call the DCON protocol. Communication between the module and the host is in ASCII format via an RS-485 bi-directional serial bus standard. Baud Rates are software programmable and transmission speeds of up to 115.2 Kbps can be selected.

The functionality of the M-7000 series is the same as the I-7000 series, with the exception that the M-7000 series offers extended support for the Modbus RTU protocol.

Some I-7000 modules feature a new design for the frame ground and INIT switch as shown in the figure (rear view). The frame ground provides enhanced static protection (ESD) abilities and ensures the module is more reliable. The INIT switch allows easier access to INIT mode. Please refer to Sections A.1 and A.3 for more details.

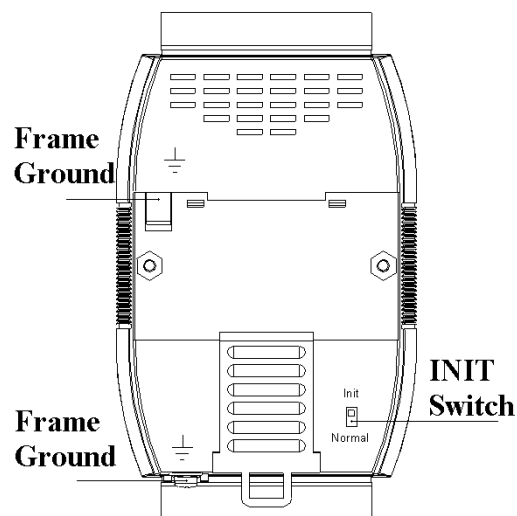

The I-7000 and M-7000 DIO modules support TTL signal, photo-isolated digital input, AC voltage digital input, relay contact output, solid-state relay output, photoMOS output and open-collector output.

1.1 More Information

For more information regarding the I-7000 series, please refer to chapter 1 of the “I-7000 Bus Converter User’s Manual” as shown below or visit the ICP DAS website <http://www.icpdas.com>.

| | |
|-----|--|
| 1.1 | The 7000 Series Overview |
| 1.2 | Related Documentation for the 7000 Series |
| 1.3 | Common Features of the 7000 Series |
| 1.4 | The 7000 Series System Network Configuration |
| 1.5 | 7000 Dimensions |

- For details of **INIT mode** operation, please refer to Section A.1 INIT Mode.
- For details of **module watchdog** and **host watchdog**, please refer to Section A.2 Dual Watchdog Operation.
- For details of **ESD protection** and **grounding**, please refer to Section A.3 Frame Ground.
- The **node information area** can be written with some information, please refer to Section A.4 Node Information Area for details.
- There is a way to check whether the module is reset, please refer to Section A.5 **Reset Status** for details.
- For details of the **safe value** and **power-on value** of the digital output, please refer to Section A.6 Safe Value and Power-on Value of Digital Output.
- The module with digital inputs provides the **latched digital inputs**, please refer to Section A.7 Latched Digital Input for details.
- For details of the **I/O extension modules**, please refer to Section A.8 DN Module.

1.2 Terminal Assignment

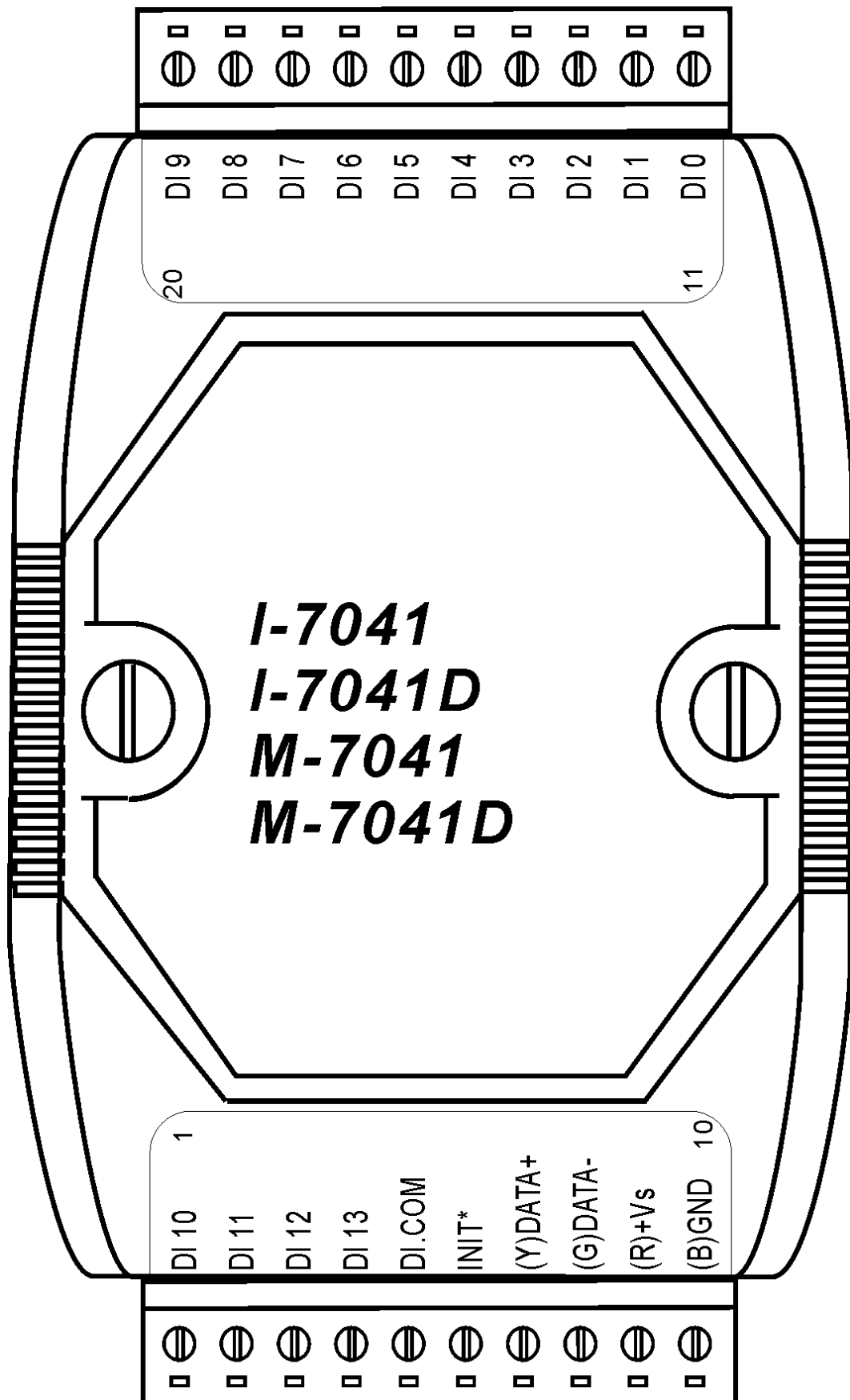

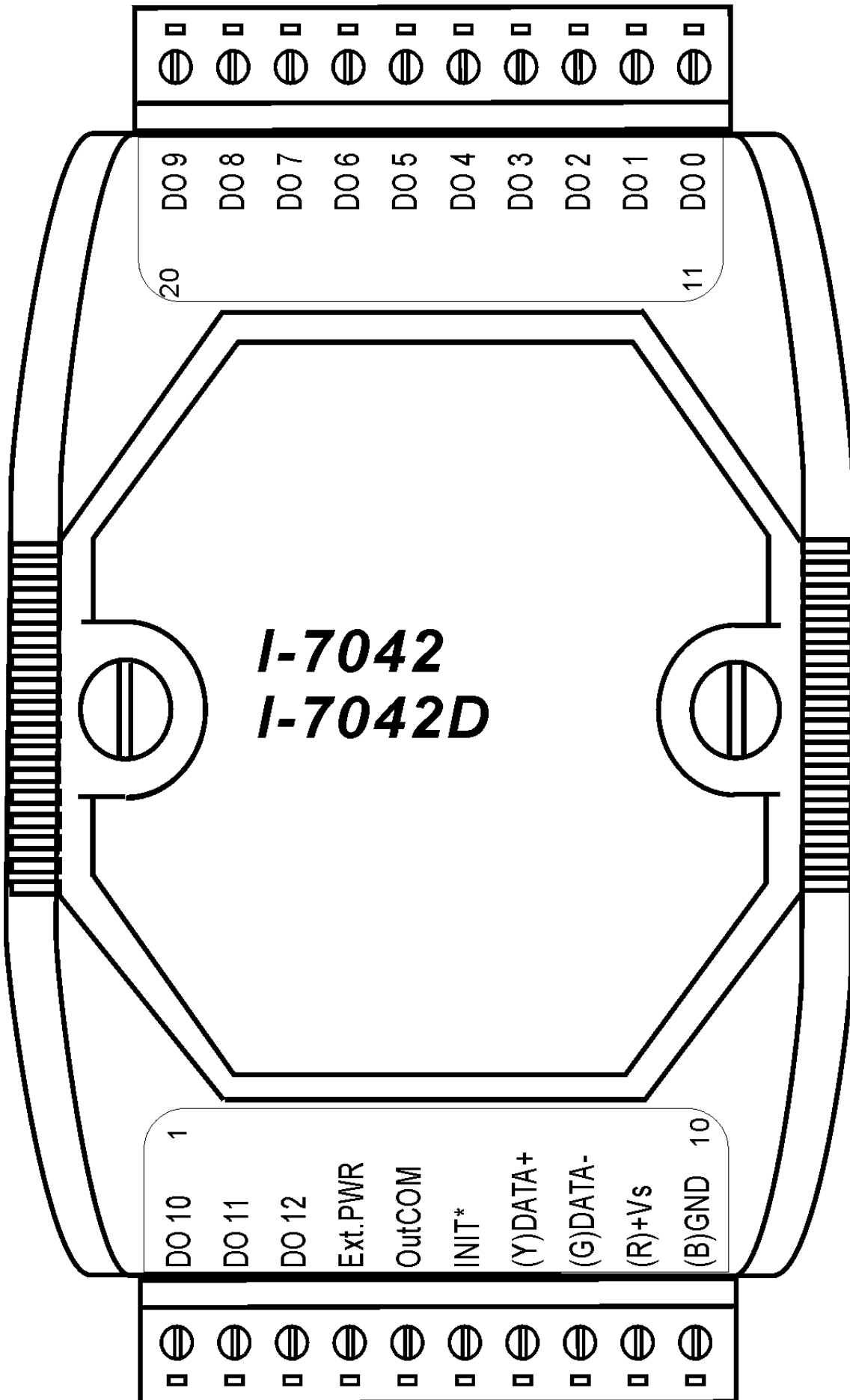

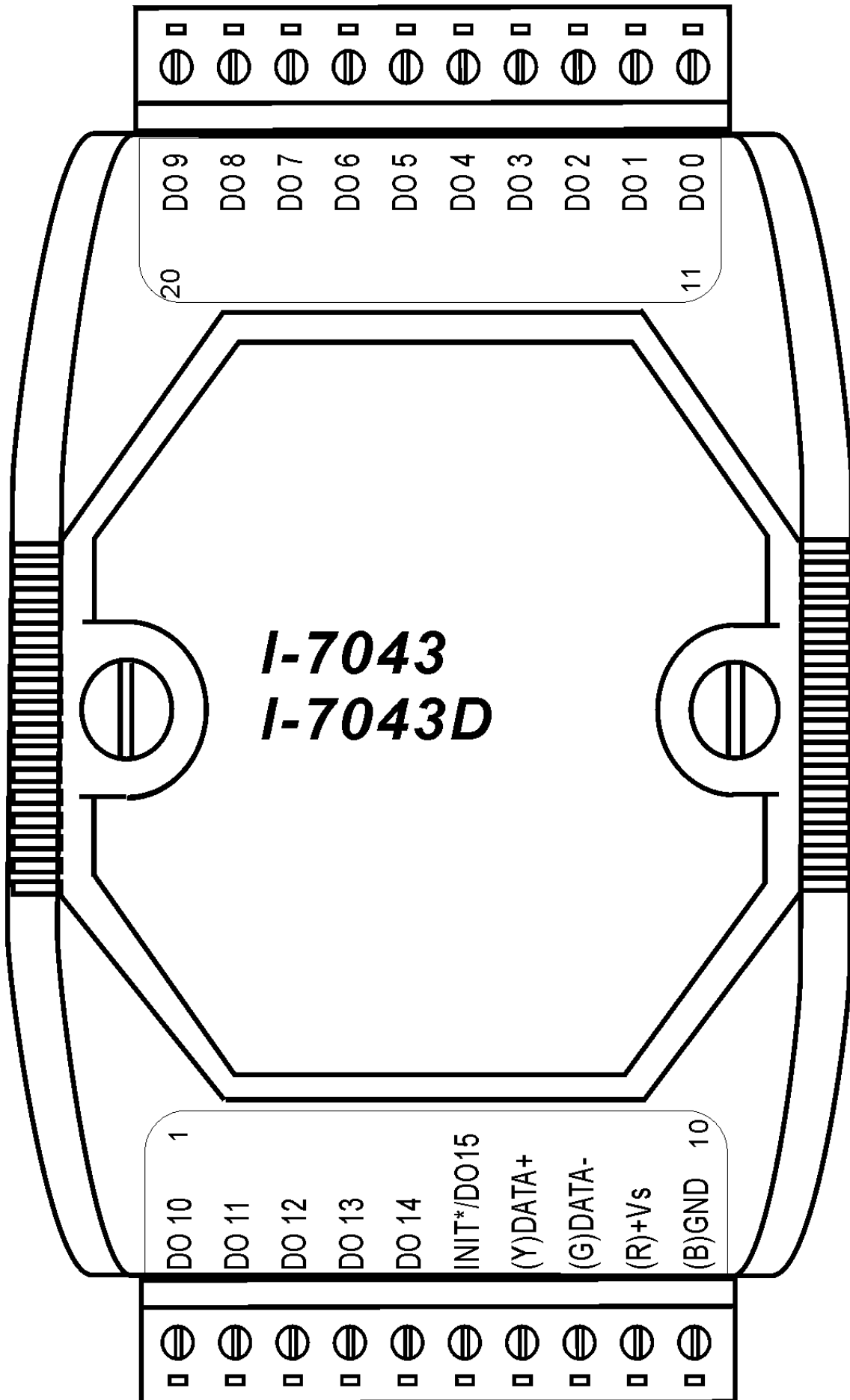

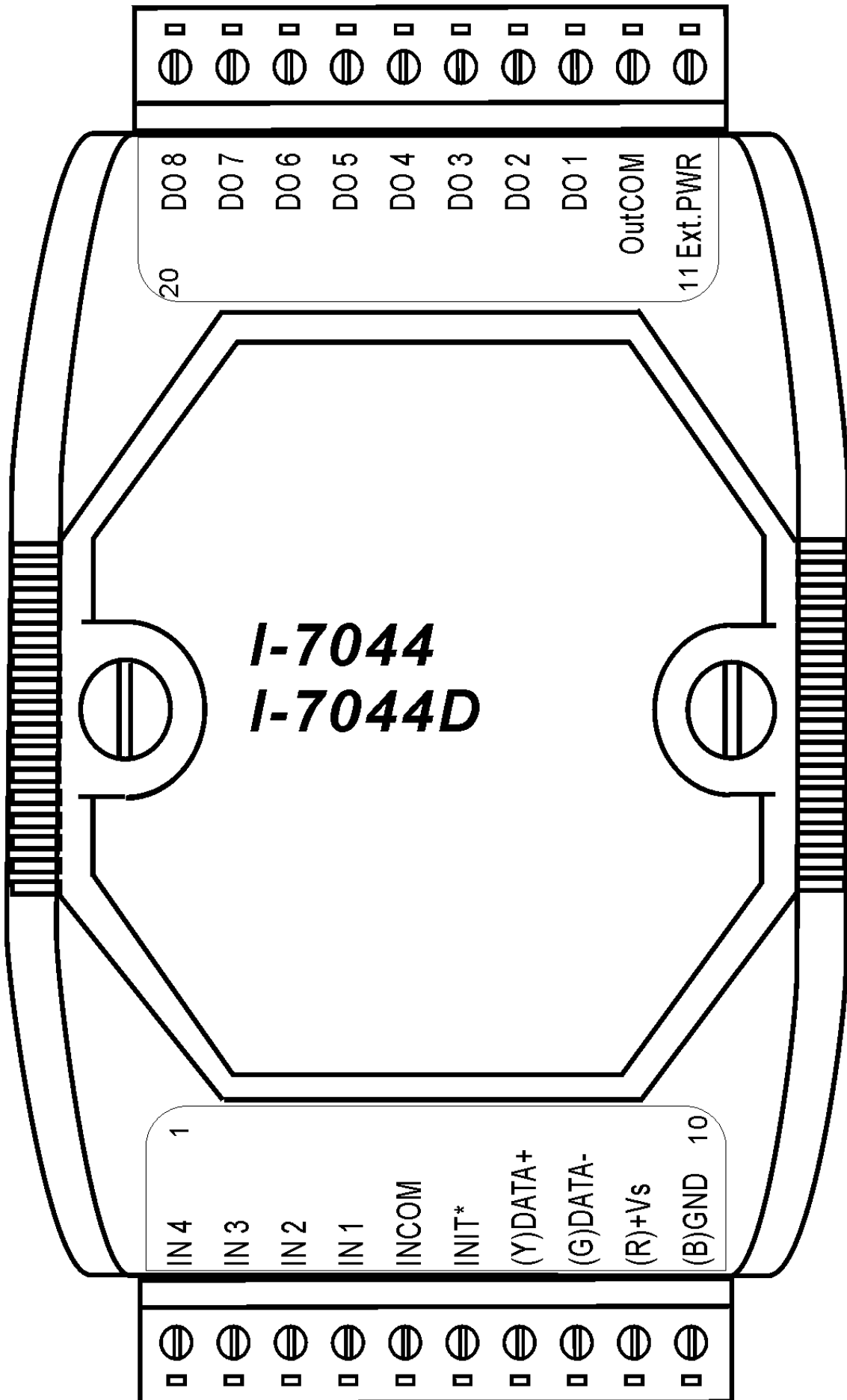

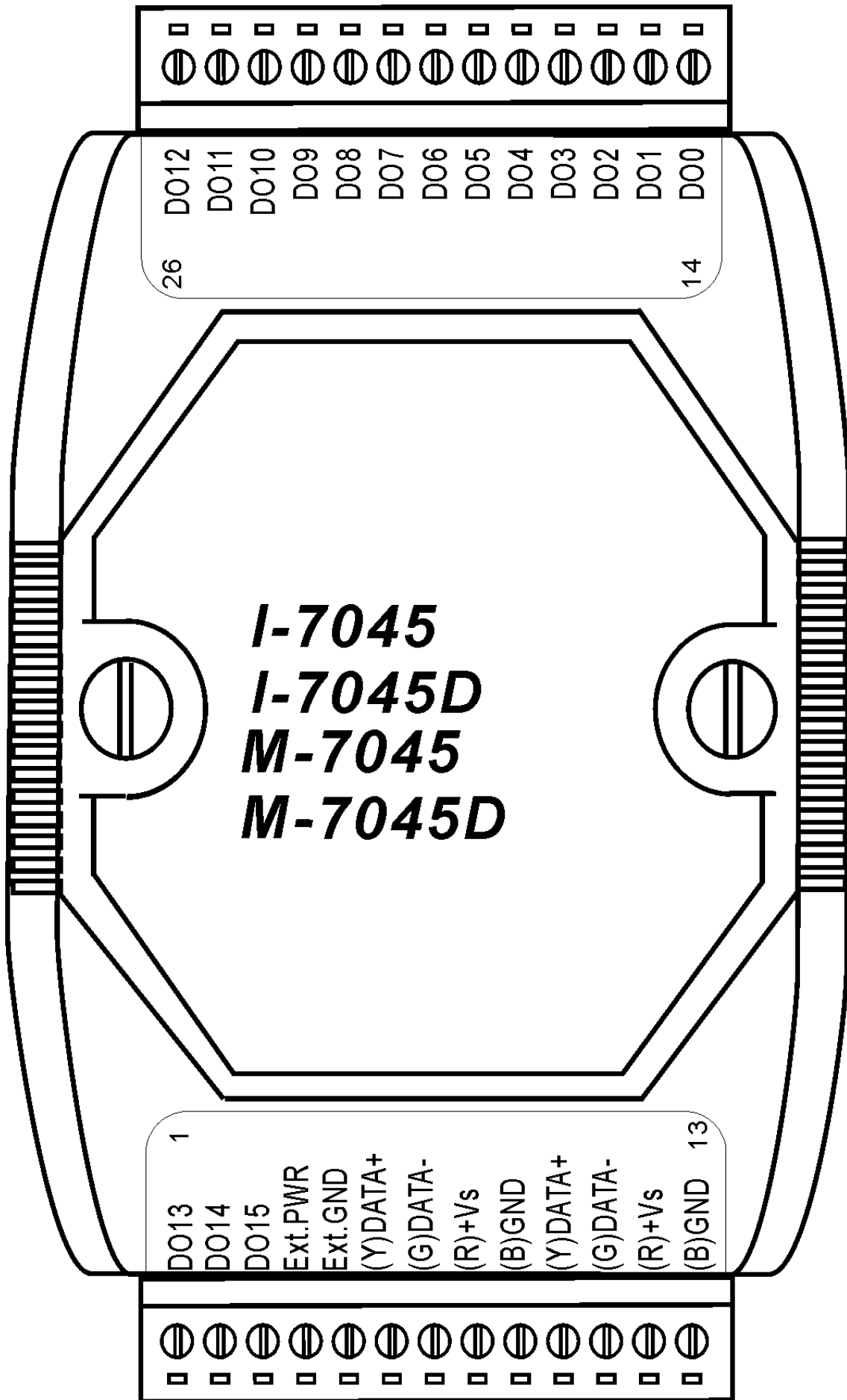

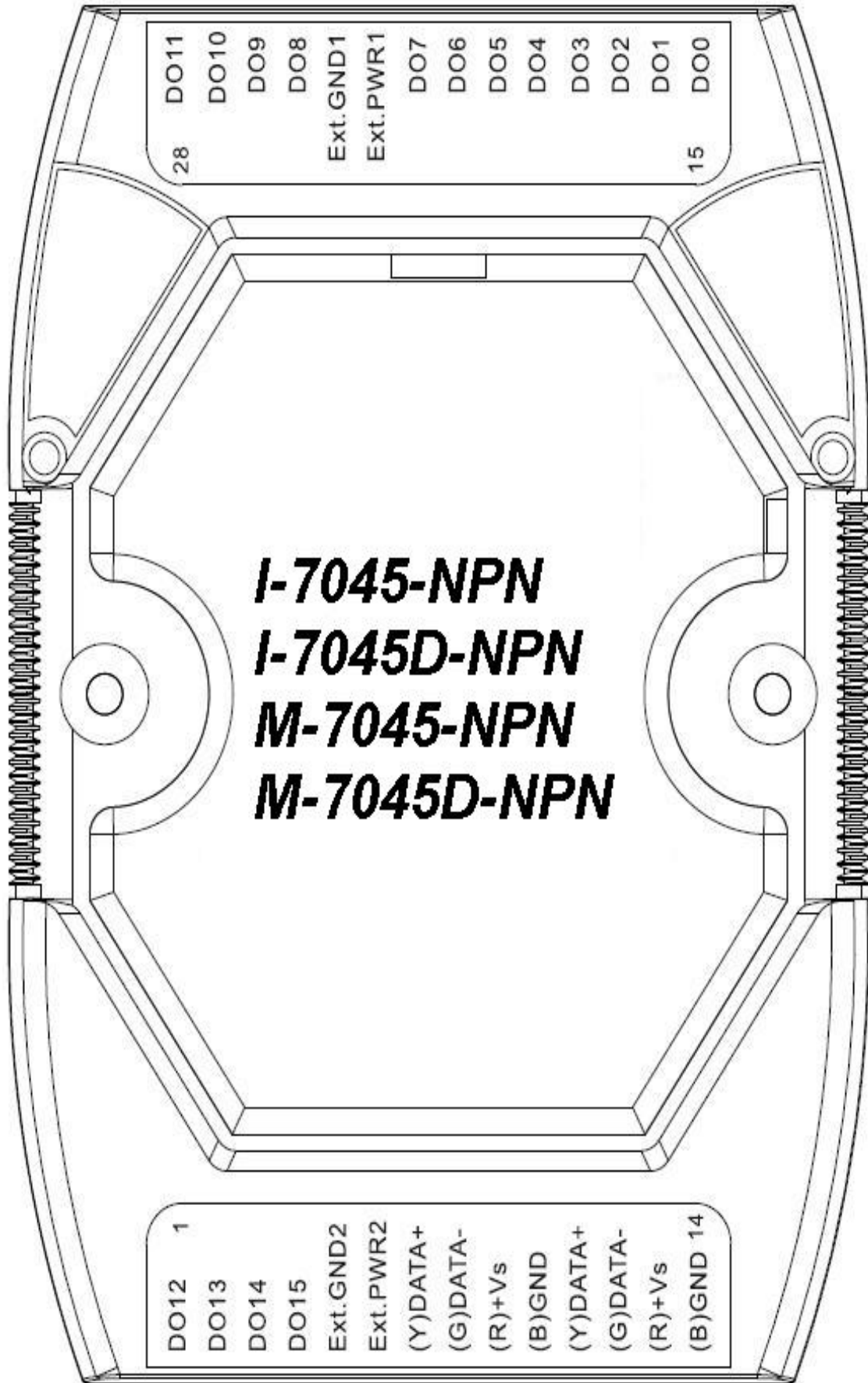

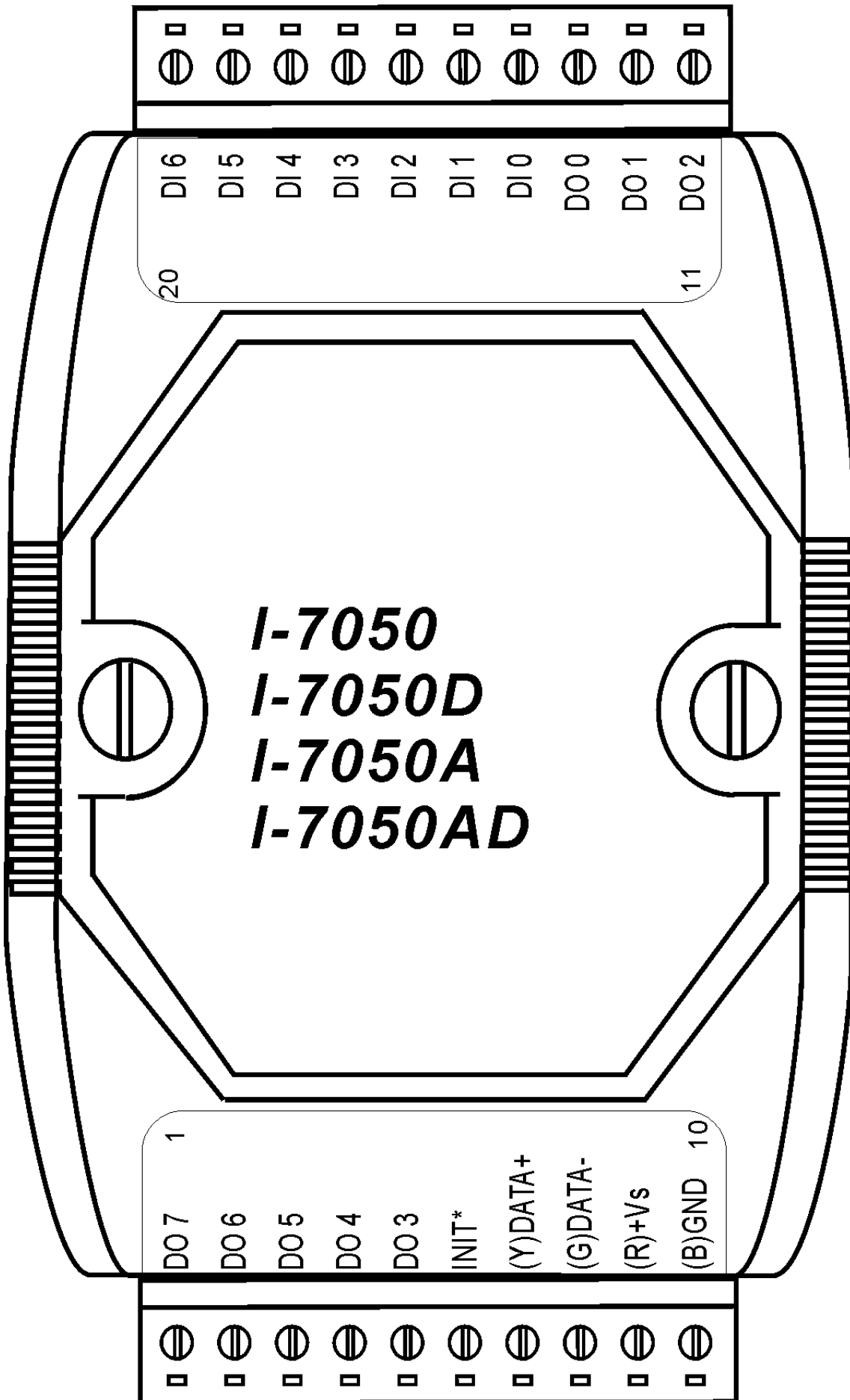

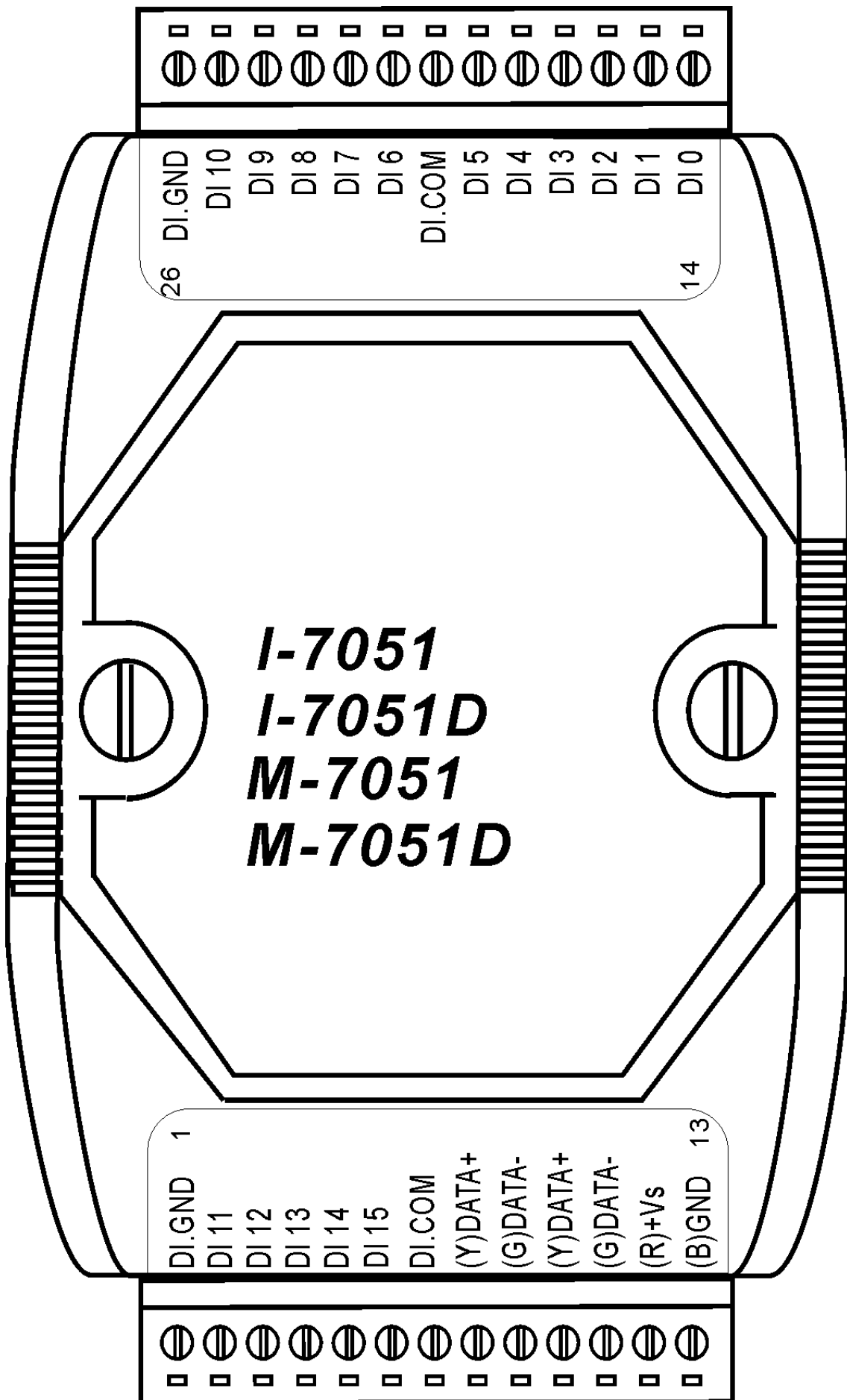

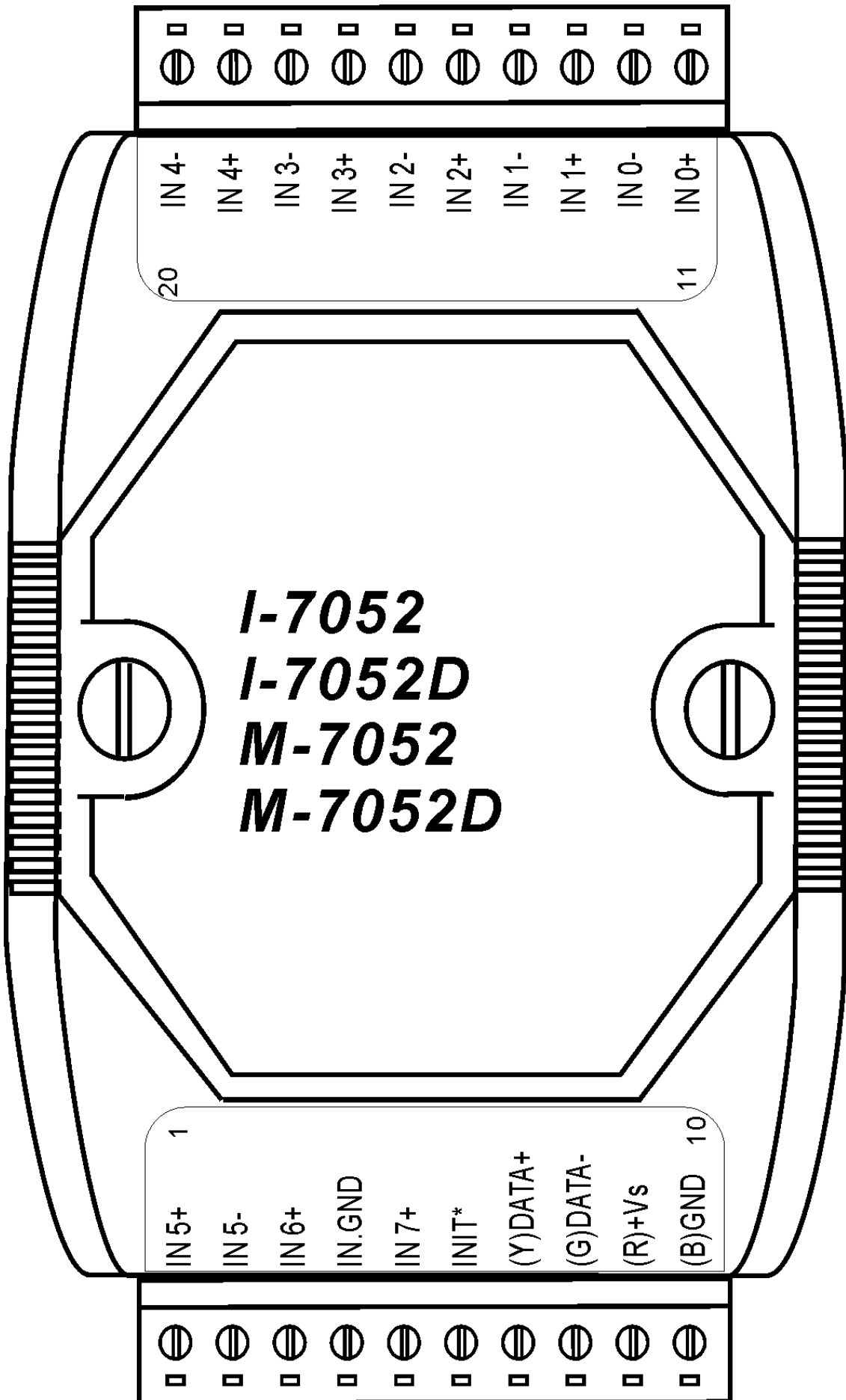

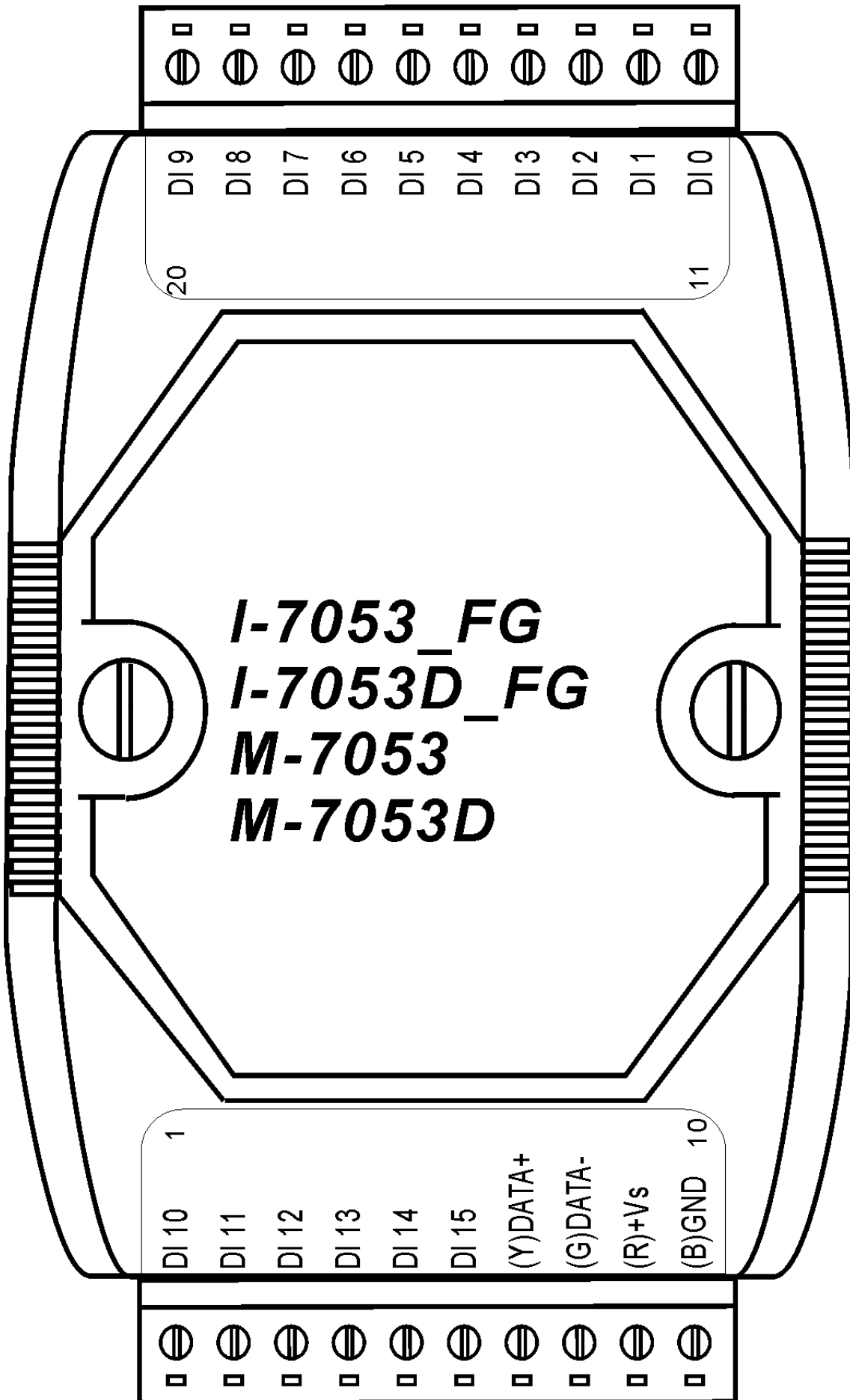

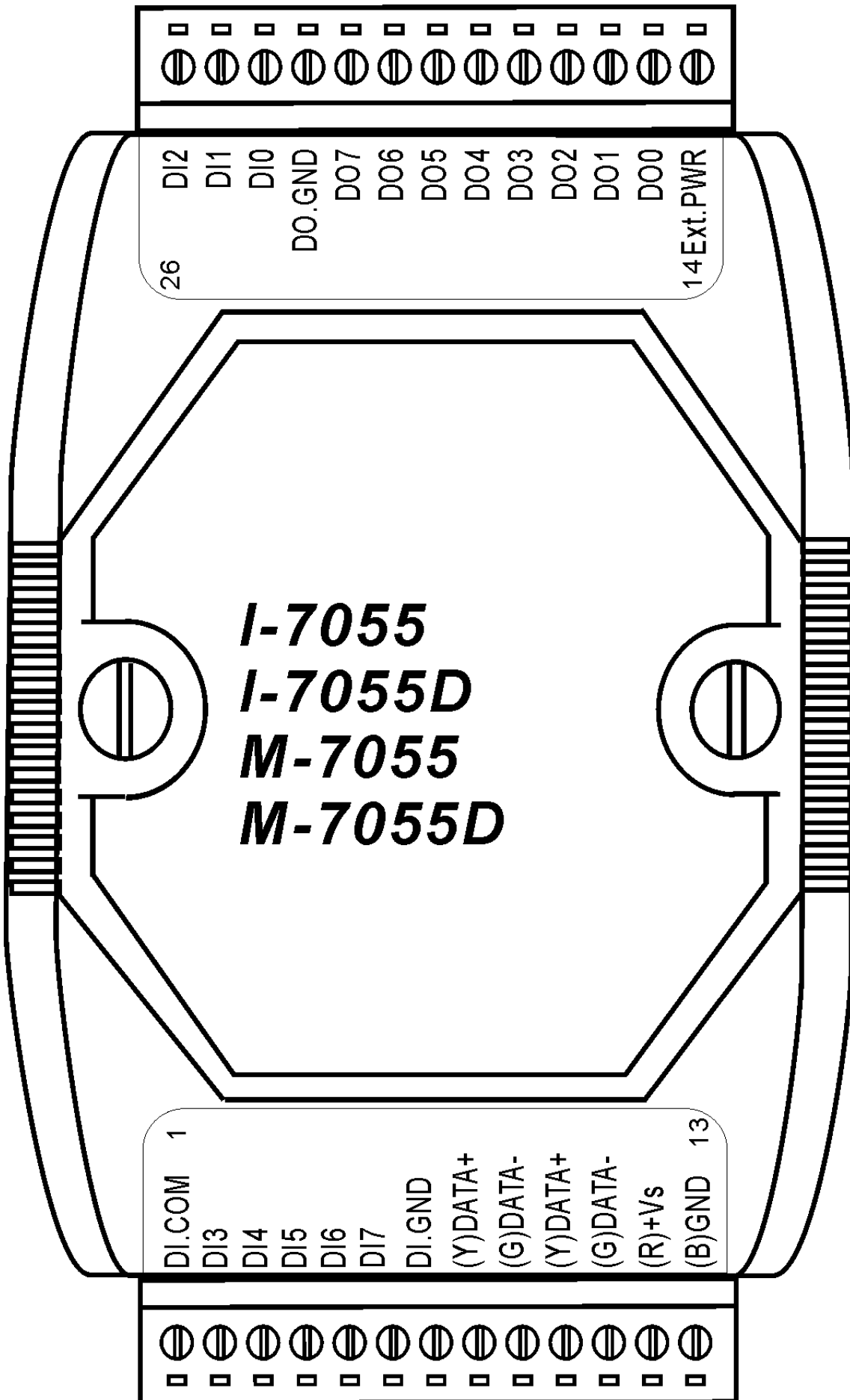

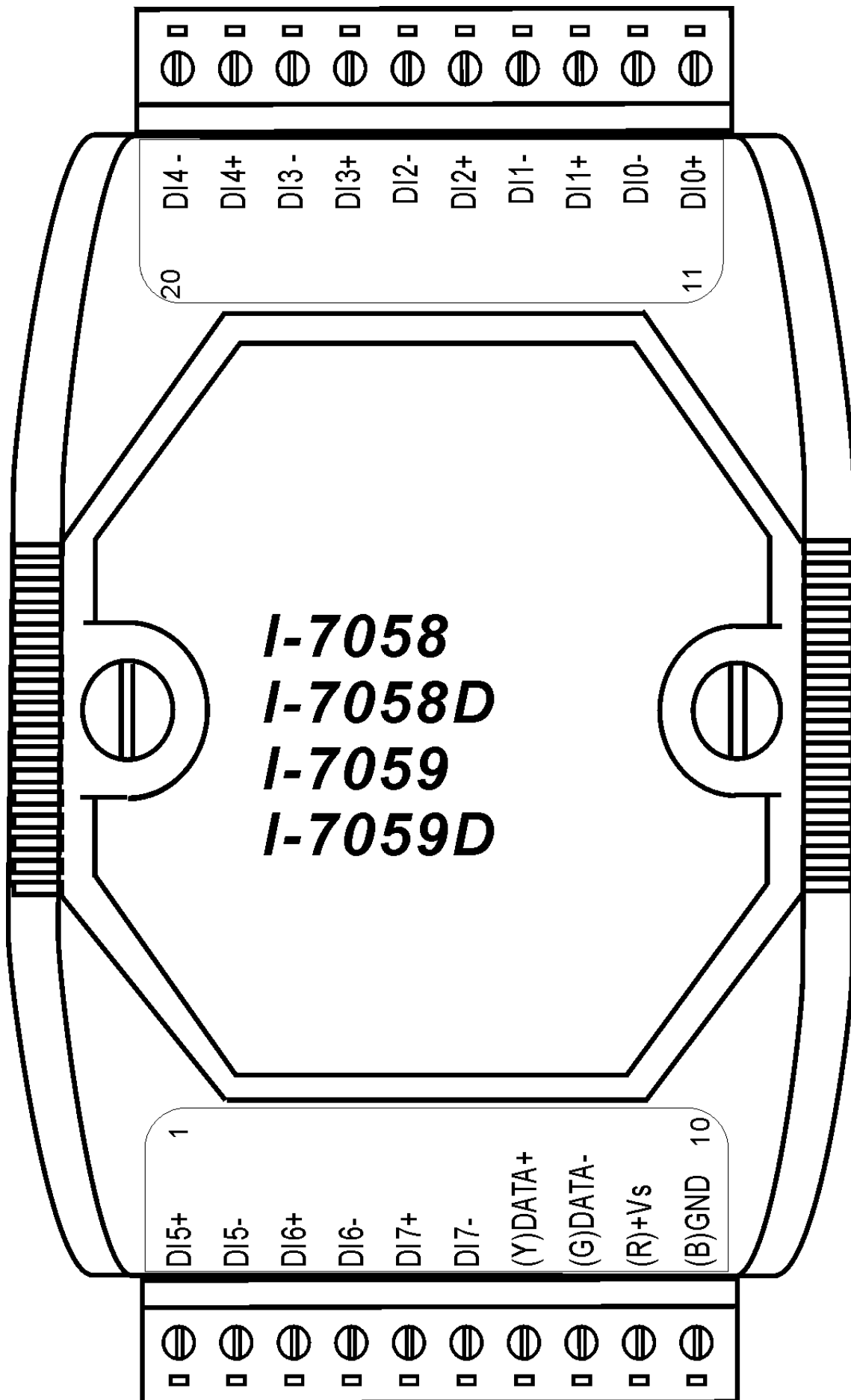

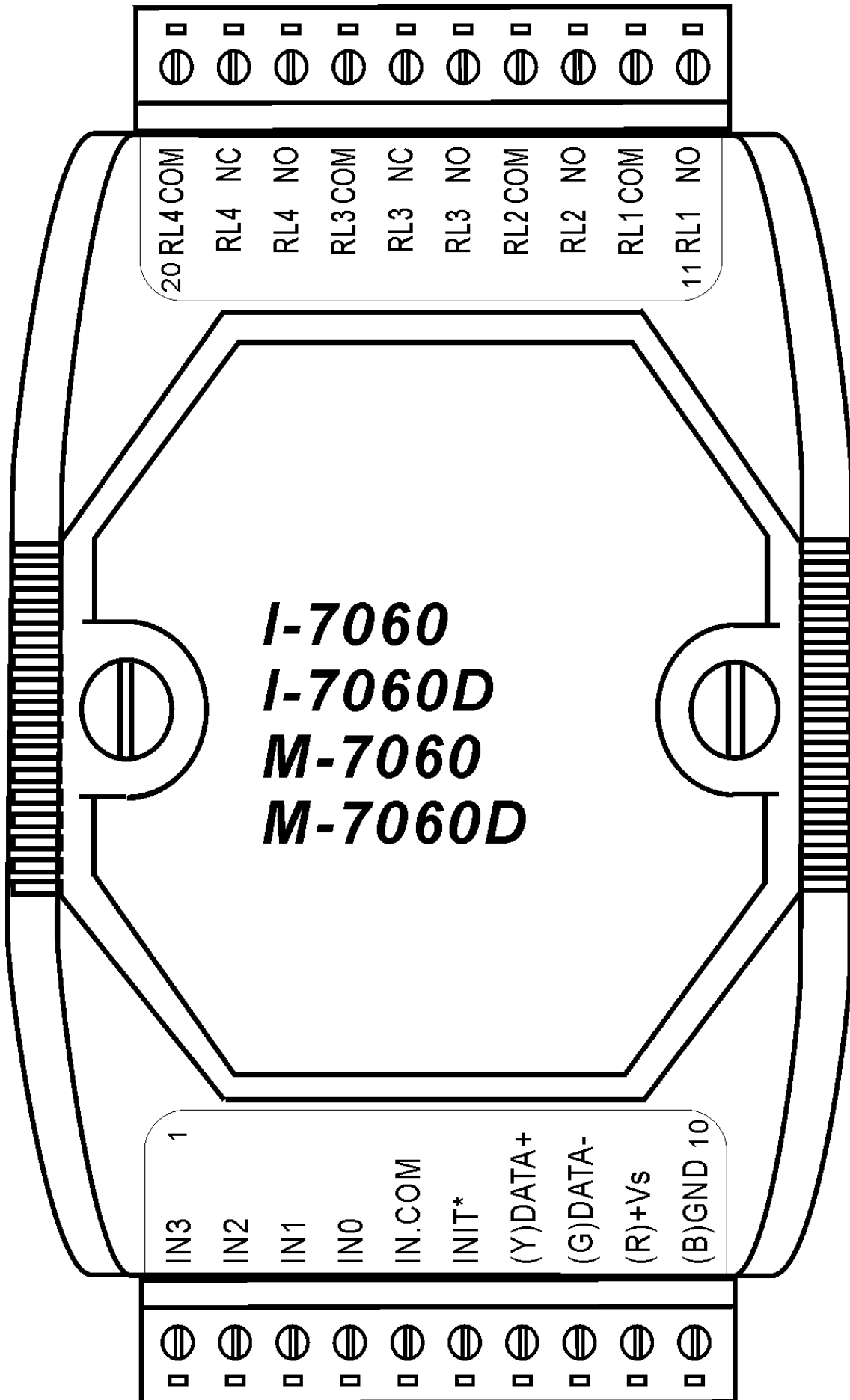

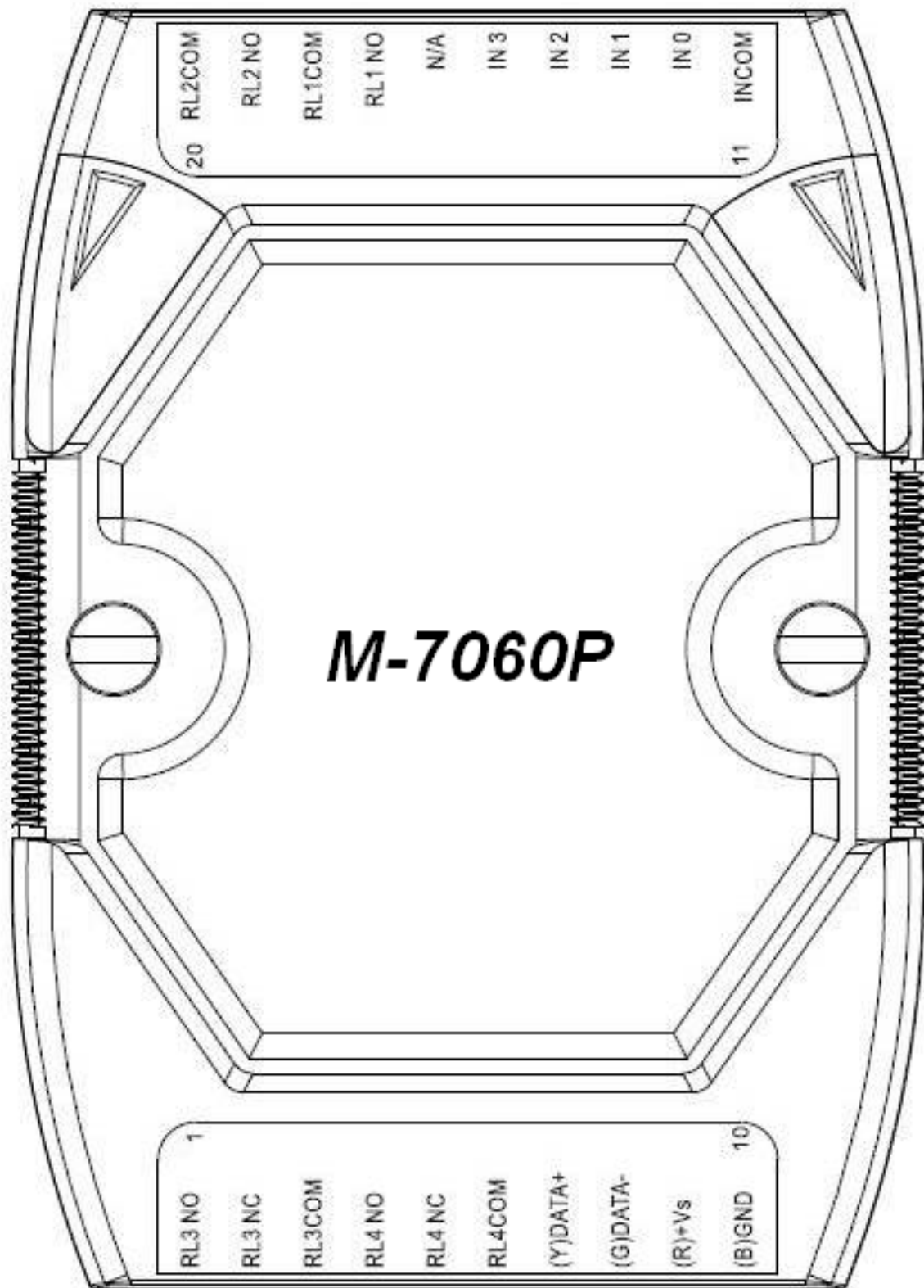

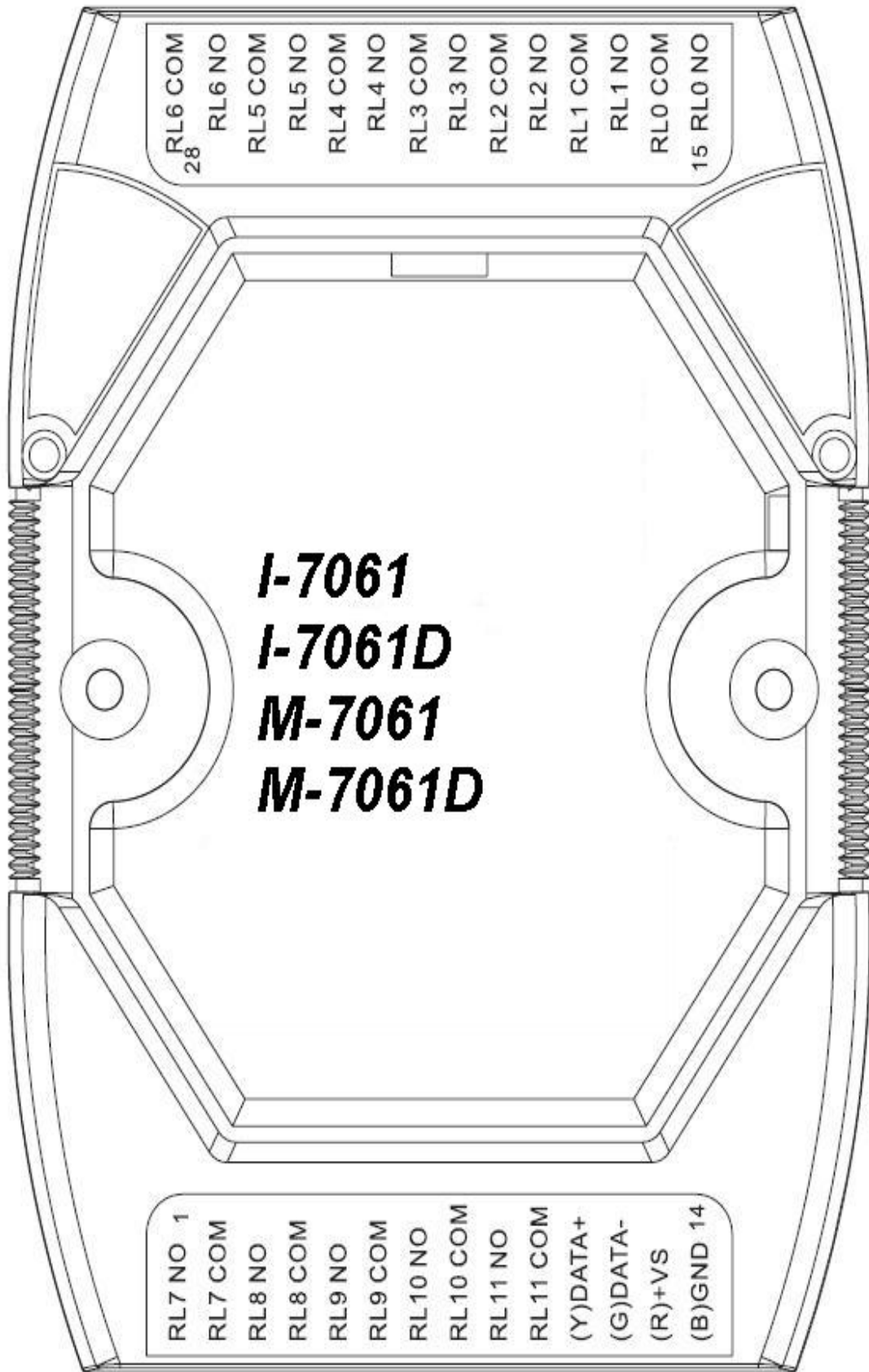

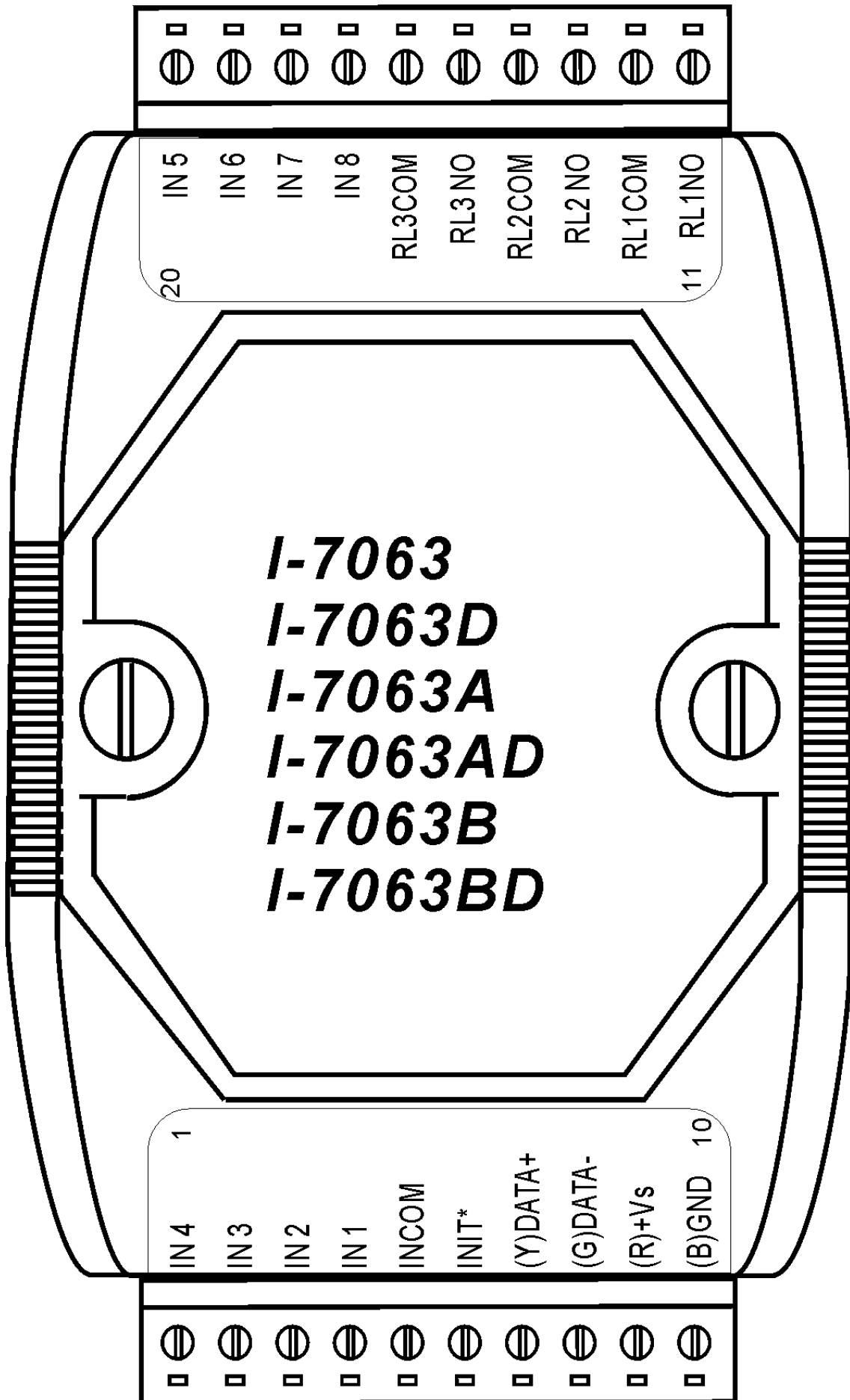

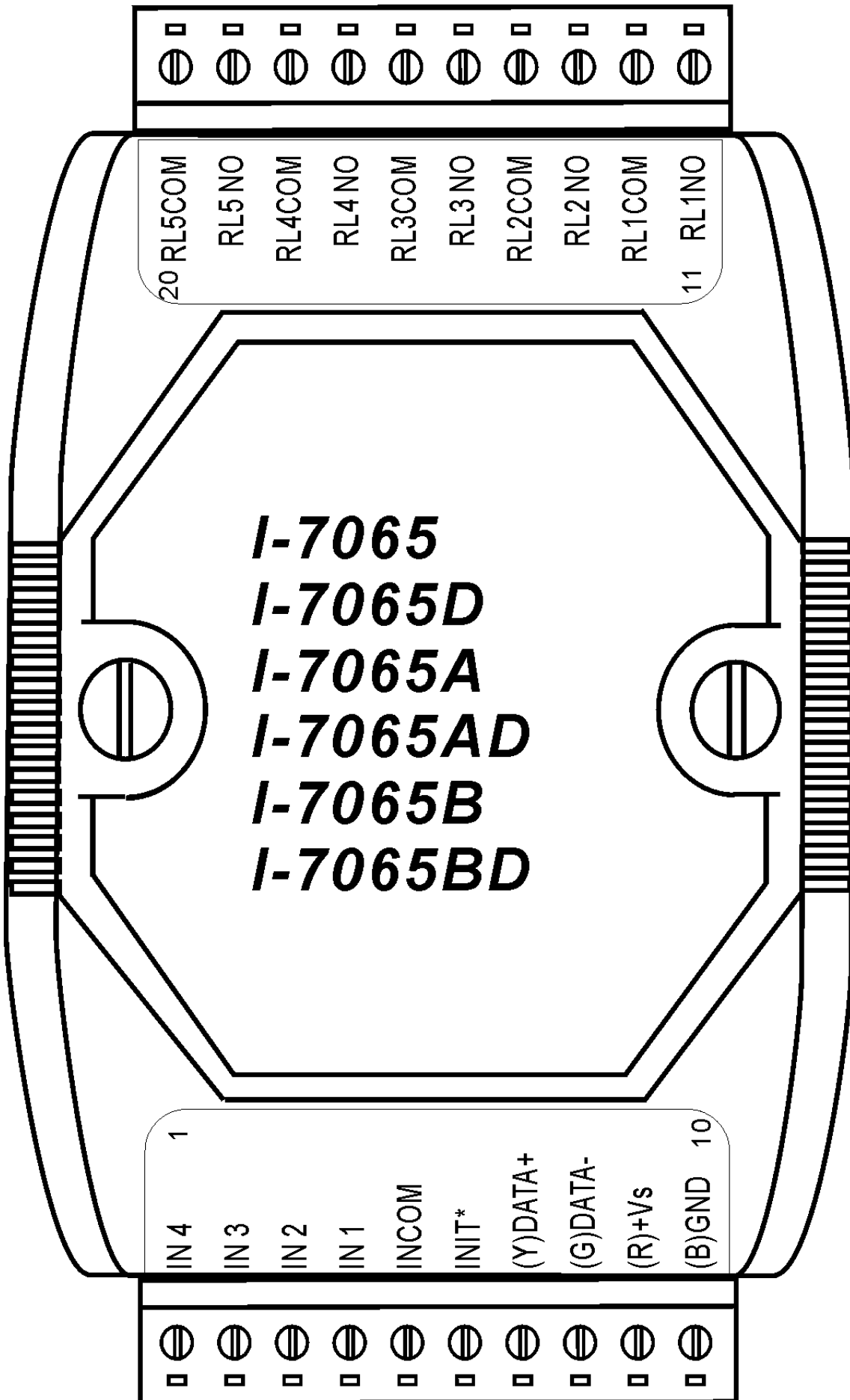

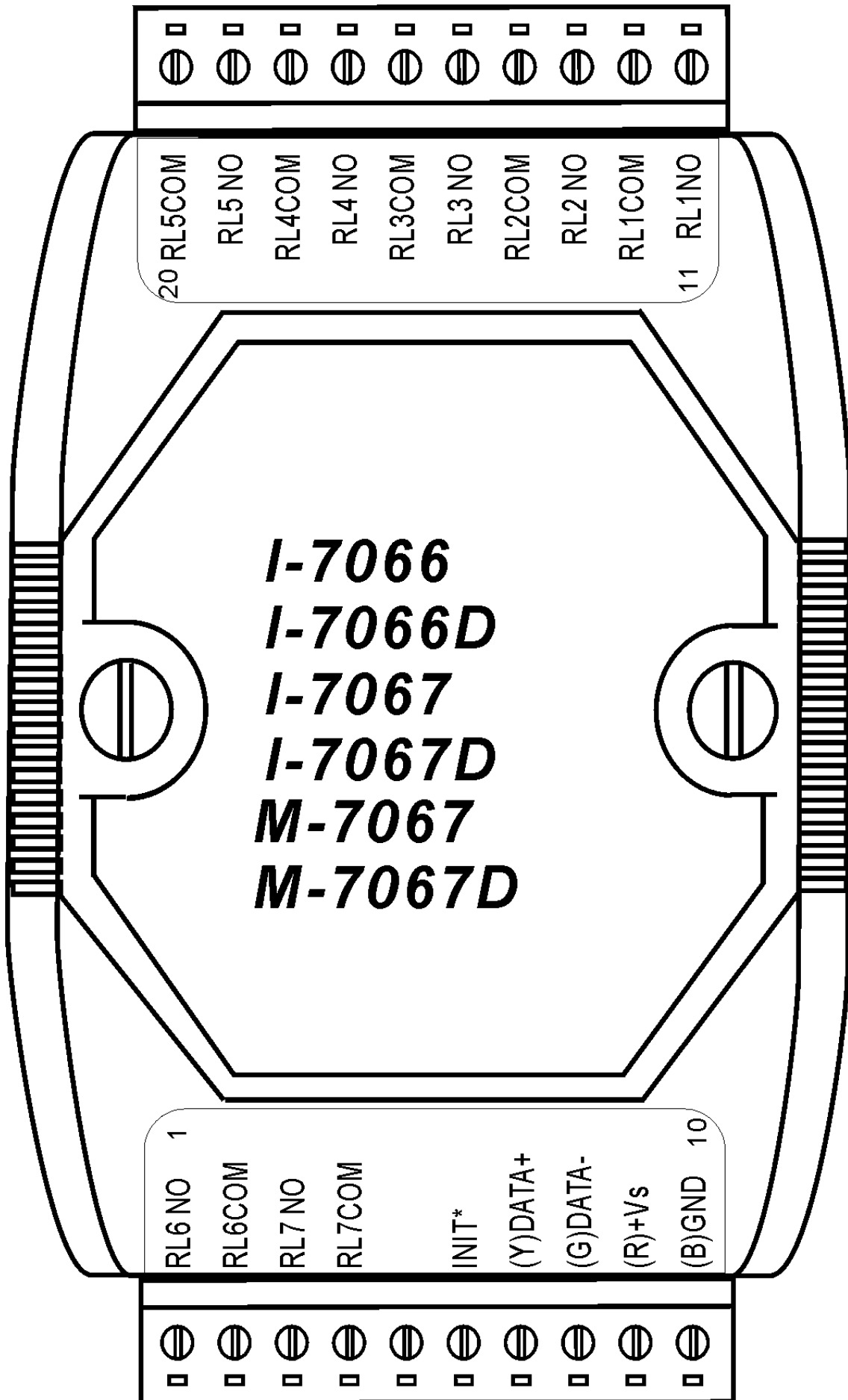

1.3 Specifications

| DC Input Modules | | | | | |
|--------------------------|--|--|--|---|--|
| Module | I-7041/41D M-7041/41D | I-7041P/41PD M-7041P/41PD | I-7051/51D M-7051/51D | I-7052/52D M-7052/52D | I-7053_FG/53D_FG M-7053/53D |
| Input Channels | 14 (Sink/Source) | 14 (Sink/Source) | 16 (Sink/Source) | 8 (Sink) | 16 (Source) |
| Input Type | Isolated with Common Power or Ground | Isolated with Common Power or Ground | Dry Contact and Wet Contact | 6 Differential and 2 Common Ground | Non-Isolated with Dry Contact |
| ON Voltage Level | +4 to +30 V | +19 to +30 V | +10 to +50 V | +4 to +30 V | Close to GND |
| OFF Voltage Level | +1 V Max. | +1 V Max. | +4 V Max. | +1 V Max. | open |
| Input Impedance | 3K Ohms | 3K Ohms | 10K Ohms | 3K Ohms | 820 Ohms |
| Isolation Voltage | 3750 Vrms | 3750 Vrms | 3750 Vrms | 5000 Vrms | Non-Isolated |
| Modbus RTU | M-7041/41D | M-7041P/41PD | M-7051/51D | M-7052/52D | M-7053/53D |
| Power Requirement | +10 to +30 VDC | | | | |
| Power Consumption | 0.2 W for I-7041/ M-7041 0.9 W for I-7041D/ M-7041D | 0.2 W for I-7041P/ M-7041P 0.9 W for I-7041PD/ M-7041PD | 0.3 W for I-7051/ M-7051 1.1 W for I-7051D/ M-7051D | 0.2 W for I-7052/ M-7052D 0.6 W for I-7052D/ M-7052D | 0.6 W for I-7053/ M-7053 1.4 W for I-7053D/ M-7053D |
| Operating Temperature | -25 °C to +75 °C | -25 °C to +75 °C | -25 °C to +75 °C | -25 °C to +75 °C | -25 °C to +75 °C |
| Storage Temperature | -30 °C to +75 °C | -30 °C to +75 °C | -30 °C to +75 °C | -30 °C to +75 °C | -30 °C to +75 °C |

| AC Input Module | | |
|------------------------|--|--|
| Module | I-7058/58D M-7058/58D | I-7059/59D M-7059/59D |
| Input Channels | 8 | 8 |
| Input Type | Differential | Differential |
| ON Voltage Level | > 80 VAC Min. | > 10 VAC Min. |
| OFF Voltage Level | < 30 VAC Max. | < 3 VAC Max. |
| Max. Input Voltage | 250 VAC | 80 VAC |
| Operating AC Frequency | 47~400 Hz | 47 ~ 400 Hz |
| Input Impedance | 68K Ohms | 10K Ohms |
| Isolation Voltage | 5000 Vrms | 5000 Vrms |
| Modbus RTU | M-7058/58D | M-7059/59D |
| Power Requirement | +10 to +30 VDC | +10 to +30 VDC |
| Power Consumption | 0.3 W for I-7058/M-7058 0.7 W for I-7058D/M-7058D | 0.3 W for I-7059/M-7059 0.7 W for I-7059D/M-7059D |
| Operating Temperature | -25 °C to +75 °C | -25 °C to +75 °C |
| Storage Temperature | -30 °C to +75 °C | -30 °C to +75 °C |

| DC Output Modules | | | | |
|--------------------------|---------------------------------------|---------------------------------------|---|---|
| Module | I-7042/42D | I-7043/43D | I-7045/45D M-7045/45D | I-7045-NPN/45D-NPN M-7045-NPN/45D-NPN |
| Output Channels | 13 (Sink) | 16 (Sink) | 16 (Source) | 16 (Sink) |
| Output type | Open Collector (NPN) | Open Collector (NPN) | Open Source (N-MOSFET) | Open Collector (NPN) |
| Load Voltage | +3.5 to +30 V | +3.5 to +30 V | +10 to +40 V | +3.5 to +50 V |
| Max Load Current | 100 mA | 100 mA | 650 mA | 700 mA |
| Short-Circuit Protection | No | No | Yes | Yes |
| Isolation Voltage | 3750 Vrms | Non-Isolated | 3750 Vrms | 3750 Vrms |
| Modbus RTU | | | M-7045/45D | M-7045-NPN/45D-NPN |
| Power Requirement | +10 to +30 VDC | | | |
| Power Consumption | 0.9 W for I-7042 1.5 W for I-7042D | 0.4 W for I-7043 1.2 W for I-7043D | 0.6 W for I/M-7045 1.5 W for I/M-7045D | 0.4 W for I/M-7045 1.2 W for I/M-7045D |
| Operating Temperature | -25 °C to +75 °C | -25 °C to +75 °C | -25 °C to +75 °C | -25 °C to +75 °C |
| Storage Temperature | -30 °C to +75 °C | -30 °C to +75 °C | -30 °C to +75 °C | -30 °C to +75 °C |

| DC Input and Output Modules | | | | | |
|------------------------------------|---------------------------------------|---------------------------------------|---|--|--|
| Module | I-7044/44D | I-7050/50D | I-7050A/50AD | I-7055/55D M-7055/55D | I-7055-NPN I-7055D-NPN M-7055-NPN M-7055D-NPN |
| Output Channels | 8 (Sink) | 8 (Sink) | 8 (Source) | 8 (Source) | 8 (Sink) |
| Output Type | Open Collector (NPN) | Open Collector (NPN) | Open Collector (PNP) | Open Source (N-MOSFET) | Open Collector (NPN) |
| Load Voltage | +3.5 to +30 V | +3.5 to +30 V | +3.5 to +30 V | +10 to +40 V | +3.5 to +50 V |
| Max Load Current | 375 mA | 30 mA | 50 mA | 650 mA | 700 mA |
| Short-Circuit Protection | No | No | No | Yes | Yes |
| Isolation Voltage | 3750 Vrms | Non-Isolated | Non-Isolated | 3750 Vrms | 3750 Vrms |
| Input Channels | 4 (Sink/Source) | 7 (Source) | 7 (Sink) | 8 (Sink/Source) | 8 (Sink/Source) |
| Input Type | Isolated with Common Source | Non-Isolated | Non-Isolated | Dry Contact and Wet Contact | Dry Contact and Wet Contact |
| ON Voltage Level | +4 to +30 V | +4 to +30 V | +4 to +30 V | +10 to +50 V | +10 to +50 V |
| OFF Voltage Level | +1 V Max. | +1 V Max. | +1 V Max. | +4 V Max. | +4 V Max. |
| Input Impedance | 3K Ohms | - | - | 10K Ohms | 10K Ohms |
| Isolation Voltage | 3750 Vrms | Non-Isolated | Non-Isolated | 3750 Vrms | 3750 Vrms |
| Modbus RTU | | | | M-7055/55D | M-7055-NPN M-7055D-NPN |
| Power Requirement | +10 to +30 V | | | | |
| Power Consumption | 0.6 W for I-7044 1.2 W for I-7044D | 0.4 W for I-7050 1.2 W for I-7050D | 1.0 W for I-7050A 1.8 W for I-7050AD | 0.8 W for I-7055/ M-7055 1.6 W for I- 7055D/ M-7055D | 1.2 W for I-7055-NPN/ M-7055-NPN 2.2 W for I-7055D-NPN/ M-7055D-NPN |
| Operating Temperature | -25 °C to +75 °C | -25 °C to +75 °C | -25 °C to +75 °C | -25 °C to +75 °C | -25 °C to +75 °C |
| Storage Temperature | -30 °C to +75 °C | -30 °C to +75 °C | -30 °C to +75 °C | -30 °C to +75 °C | -30 °C to +75 °C |

| Relay Output and DC Input Modules | | | | |
|--|--|---------------------------------------|---------------------------------------|---|
| Module | I-7060/60D M-7060/60D | I-7063/63D | I-7065/65D | M-7060P |
| Output Channels | 4 | 3 | 5 | 4 |
| Relay Type | RL1, RL2: Form A RL3, RL4: Form C | Form A | Form A | RL1, RL2: Form A RL3, RL4: Form C |
| Contact Rating | 0.6A@125 VAC 2A@30 VDC | 5A@250 VAC 5A@30 VDC | | Form A: 16 A@250 VAC 10A @ 30 VDC Form C: 10A(NO)/6A(NC) @250 VAC 10A(NO)/6A(NC) @30 VDC |
| Surge Strength | 500 V | 4000 V | | 2500 V |
| Operate Time | 3 ms | 6 ms Max. | | 6 ms |
| Release Time | 2 ms | 3 ms Max. | | 3 ms |
| Min. Life | 5*10 ⁵ ops. | 10 ⁵ ops. | | 5*10 ⁴ ops |
| Input Channels | 4 | 8 | 4 | 4 |
| Isolation | Isolated with Common Source | | | |
| Isolation Voltage | 3750 Vrms | | | |
| Digital Level 0 | +1 V max | | | +4 V max |
| Digital Level 1 | +4 to 30 V | | | +10 to 50 V |
| Input Impedance | 3K ohm | | | 10K ohm |
| Modbus RTU | M-7060/60D | | | M-7060P |
| Power Requirement | +10 to 30 VDC | | | |
| Power Consumption | 1.3 W for I-7060/ M-7060 1.9 W for I-7060D/ M-7060D | 1.0 W for I-7063 1.5 W for I-7063D | 1.3 W for I-7065 2.2 W for I-7065D | 1.4W for M-7060P |
| Operating Temperature | -25 °C to +75 °C | -25 °C to +75 °C | -25 °C to +75 °C | -25 °C to +75 °C |
| Storage Temperature | -30 °C to +75 °C | -30 °C to +75 °C | -30 °C to +75 °C | -30 °C to +75 °C |

| Relay Output Modules | | |
|-----------------------------|--|--|
| Module | I-7067/67D M-7067/67D | I-7061/61D M-7061/61D |
| Output Channels | 7 | 12 |
| Relay Type | Form A | Form A |
| Contact Rating | 0.5A@120 VAC 1.0A@24 VDC | 5A@250 VAC 5A@30 VDC |
| Surge Strength | 1500 V | 3000 V |
| Operate Time | 5 ms Max. | 6 ms |
| Release Time | 2 ms Max. | 3 ms |
| Min. Life | 10 ⁵ ops. | 20*10 ⁵ ops |
| Modbus RTU | M-7067/67D | M-7061/61D |
| Power Requirement | +10 to 30 VDC | |
| Power Consumption | 1.5W for I-7067/ M-7067 2.2 W for I-7067D/ M-7067D | 1.7W for I-7061/ M-7061 2.3 W for I-7061D/ M-7061D |
| Operating Temperature | -25 °C to +75 °C | -25 °C to +75 °C |
| Storage Temperature | -30 °C to +75 °C | -30 °C to +75 °C |

| Solid-State Relay Output Modules | | | | |
|---|---|---|---|---|
| Module | I-7063A/63AD | I-7065A/65AD | I-7063B/63BD | I-7065B/65BD |
| Output Channels | 3 | 5 | 3 | 5 |
| SSR Type | AC-SSR, Normal Open | | DC-SSR, Normal Open | |
| Load Voltage Range | 24 to 265 Vrms | | 3 to 30 VDC | |
| Leakage Current | 1.5 mArms | | 0.1 mA | |
| Max Load Current | 1.0 Arms | | 1.0 A | |
| Min. Operate Time | 1mS | | | |
| Min. Release Time | 1/2 cycle +1mS | | 1 mS | |
| Dielectric Strength | 2500 Vrms | | | |
| Input Channels | 8 | 4 | 8 | 4 |
| Isolation | Isolated with Common Source | | | |
| Isolation Voltage | 3750 Vrms | | | |
| Digital Level 0 | +1 V max | | | |
| Digital Level 1 | +4 to +30 V | | | |
| Input Impedance | 3K ohms | | | |
| Power Requirement | +10 to +30 VDC | | | |
| Power Consumption | 0.7 W for I-7063A 1.5 W for I-7063AD | 0.8 W for I-7065A 1.6 W for I-7065AD | 0.6 W for I-7063B 1.4 W for I-7063BD | 0.7 W for I-7065B 1.5 W for I-7065BD |
| Operating Temperature | -25 °C to +75 °C | -25 °C to +75 °C | -25 °C to +75 °C | -25 °C to +75 °C |
| Storage Temperature | -30 °C to +75 °C | -30 °C to +75 °C | -30 °C to +75 °C | -30 °C to +75 °C |

| PhotoMos Output Module | |
|-------------------------------|---------------------------------------|
| Module | I-7066/66D |
| Output Channels | 7 |
| Load Current | 0.13 A |
| Load Voltage | 350 V max |
| Isolation Voltage | 5000 VAC |
| Turn On Time | 0.7 ms typ |
| Turn Off Time | 0.05 ms typ |
| Power Requirement | +10 to +30 VDC |
| Power Consumption | 0.5 W for I-7066 0.8 W for I-7066D |
| Operating Temperature | -25 °C to +75 °C |
| Storage Temperature | -30 °C to +75 °C |

1.4 Block Diagrams

1.4.1 Block Diagram for the I-7041/41D, I-7041P/41PD, M-7041/41D and M-7041P/41PD

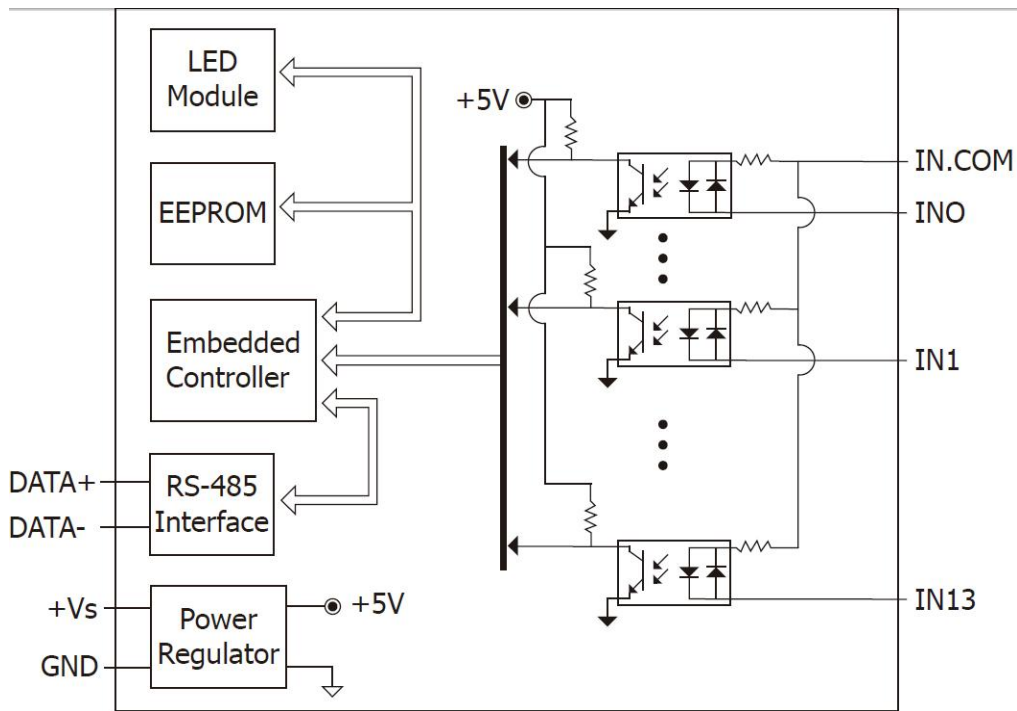

1.4.2 Block Diagram for the I-7042/42D

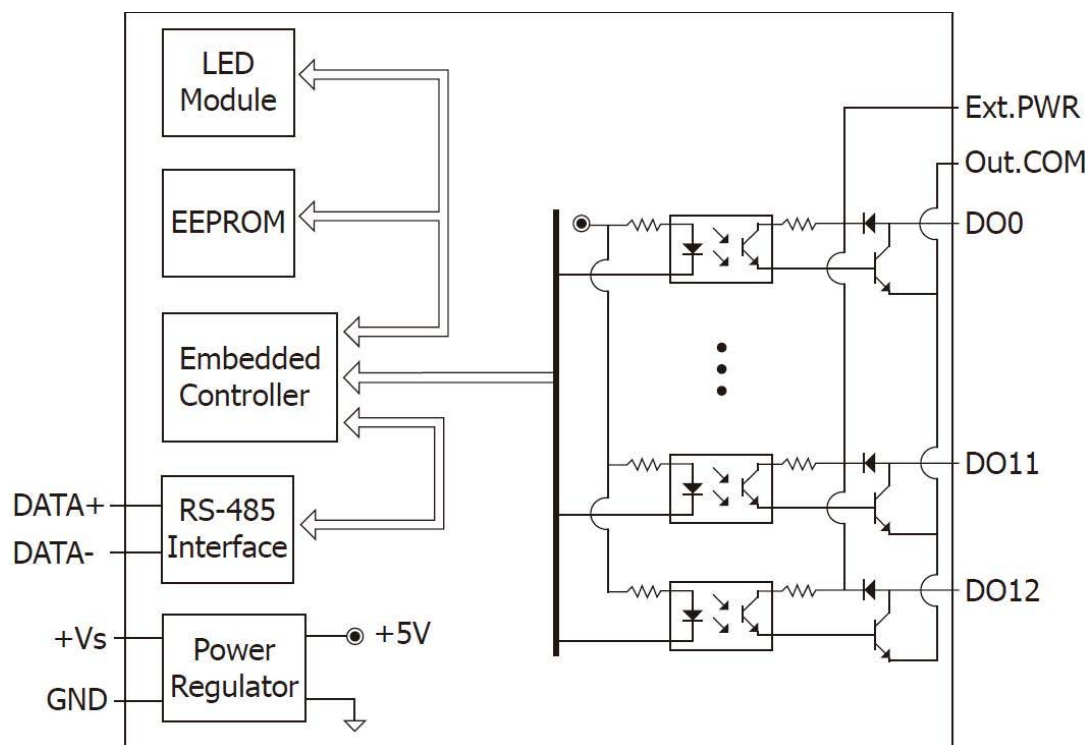

1.4.3 Block Diagram for the I-7043/43D

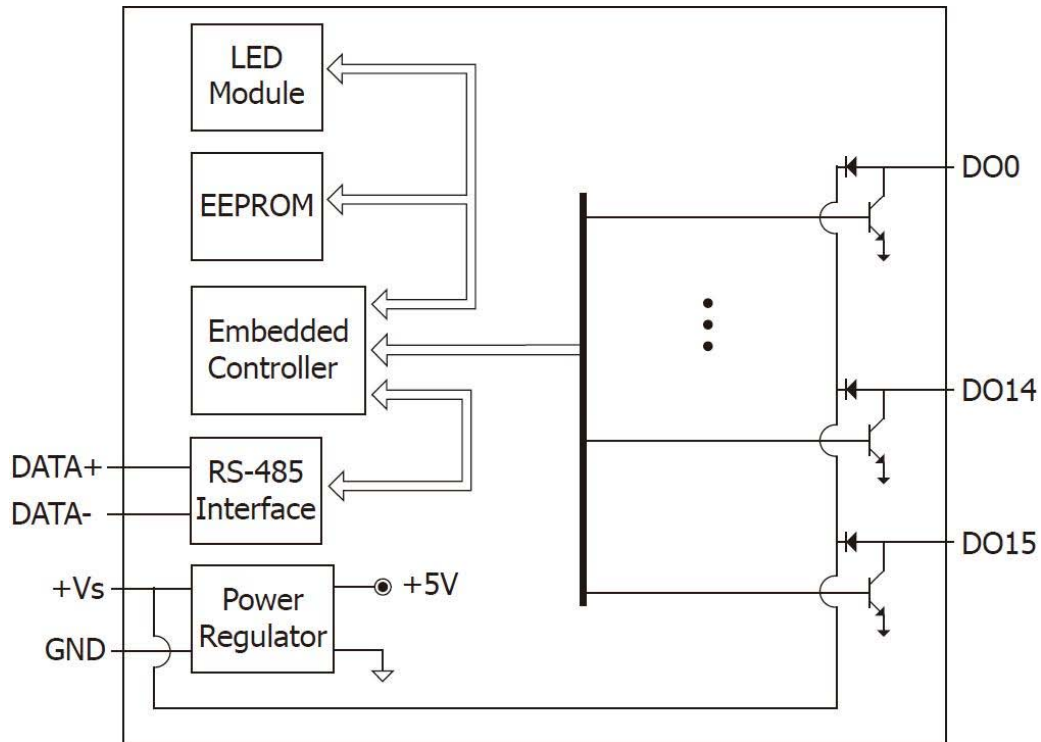

1.4.4 Block Diagram for the I-7044/44D

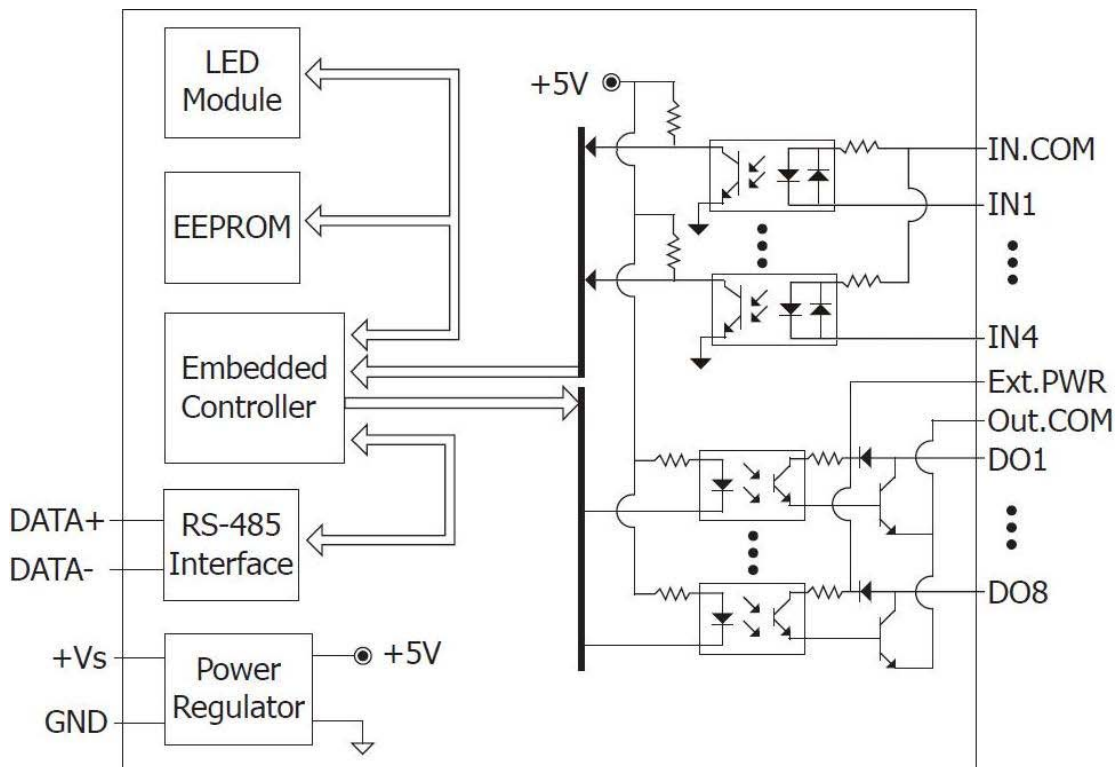

1.4.5 Block Diagram for the I-7045/45D and M-7045/45D

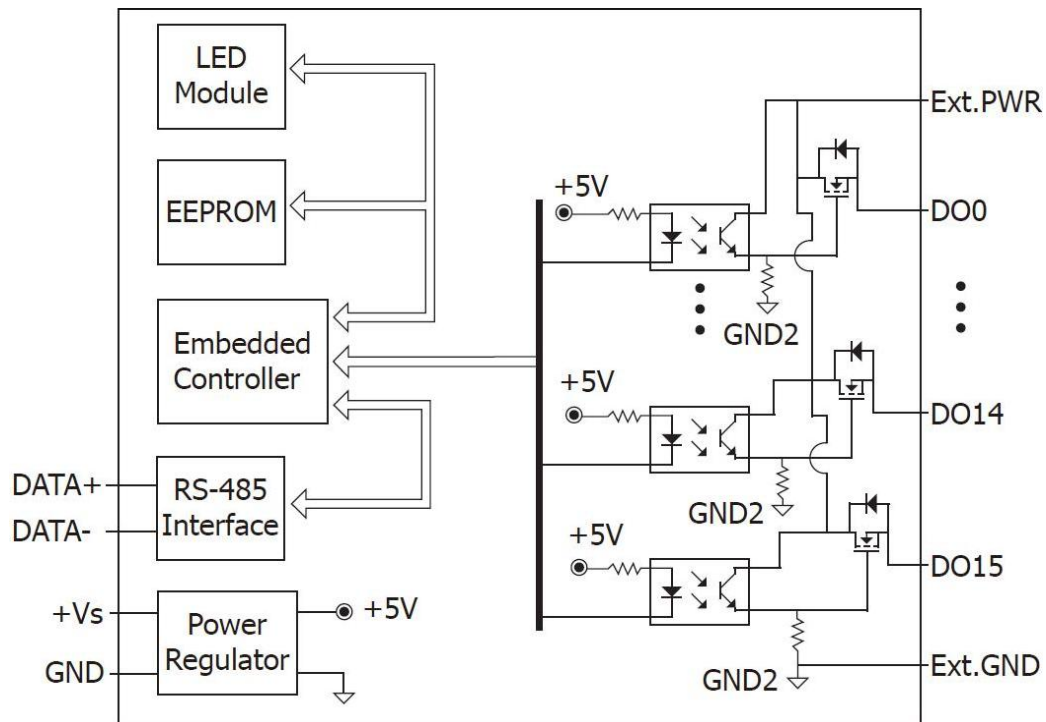

1.4.6 Block Diagram for the I-7045-NPN/45D-NPN and M-7045-NPN/45D-NPN

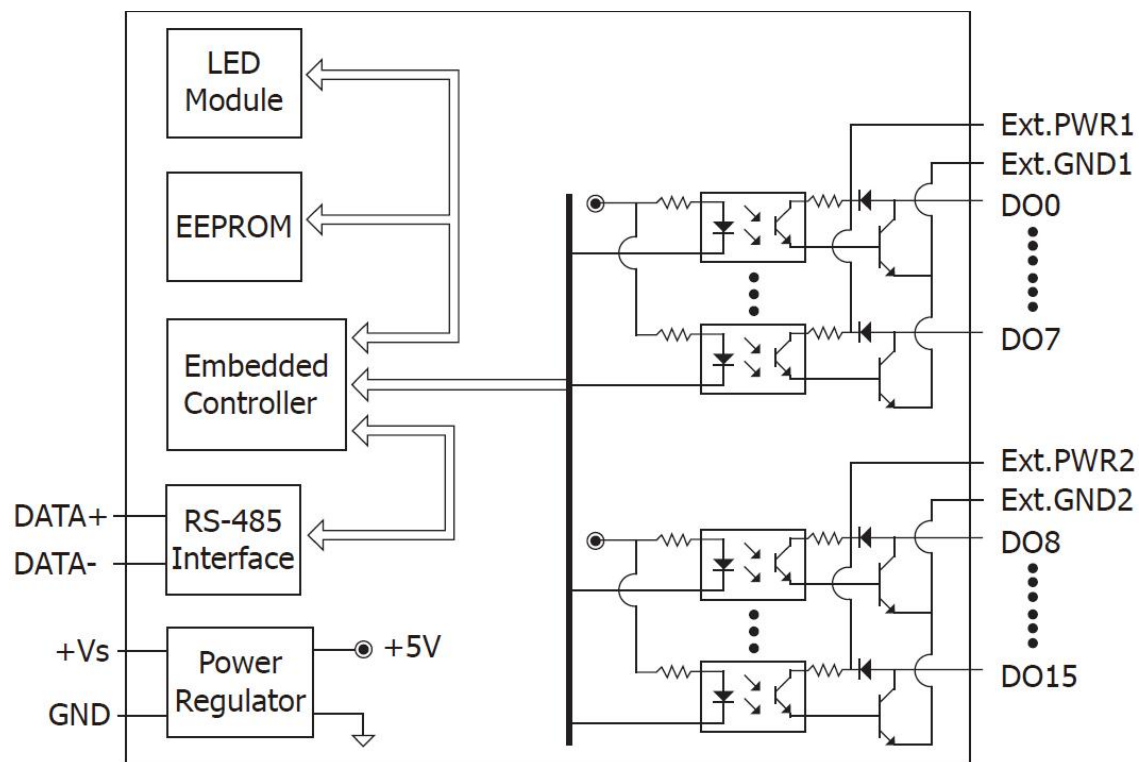

1.4.7 Block Diagram for the I-7050/50D and M-7050/50D

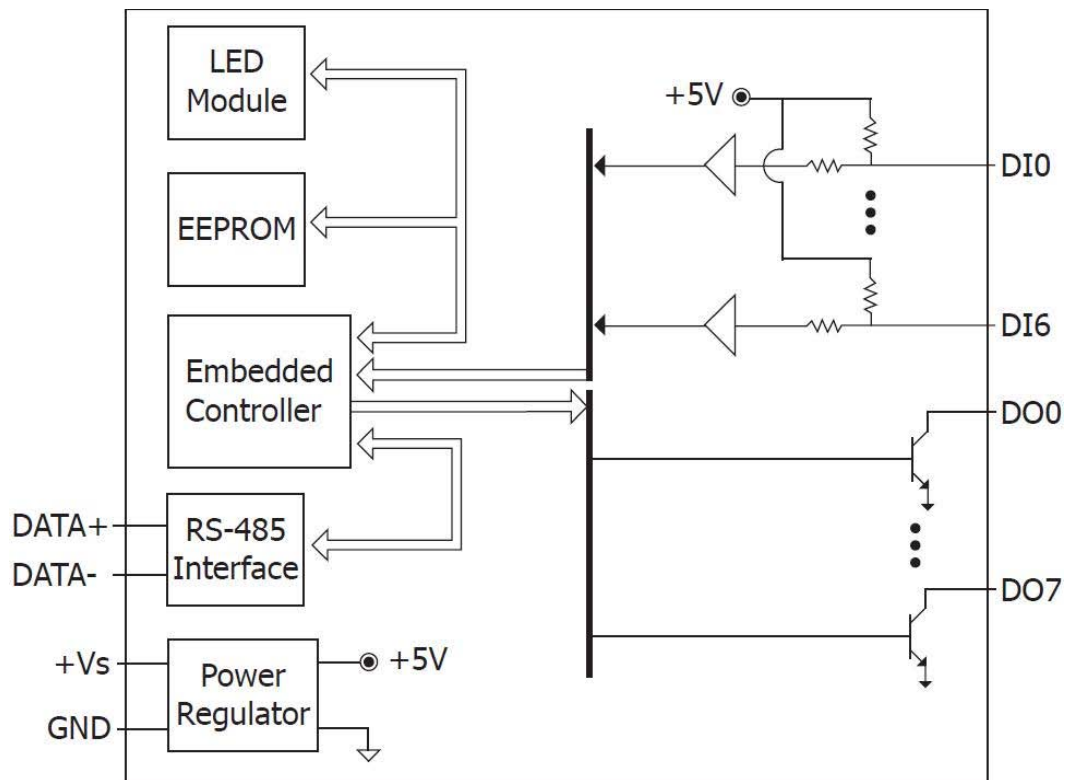

1.4.8 Block Diagram for the I-7050A/50AD

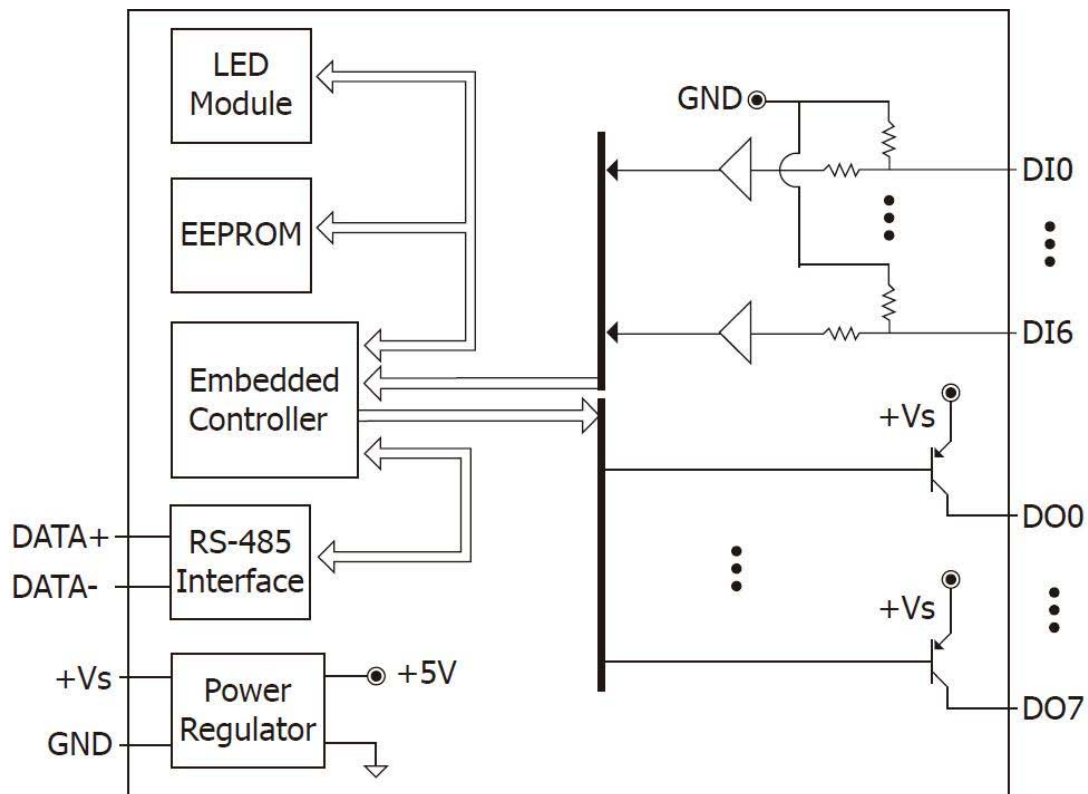

1.4.9 Block Diagram for the I-7051/51D and M-7051/51D

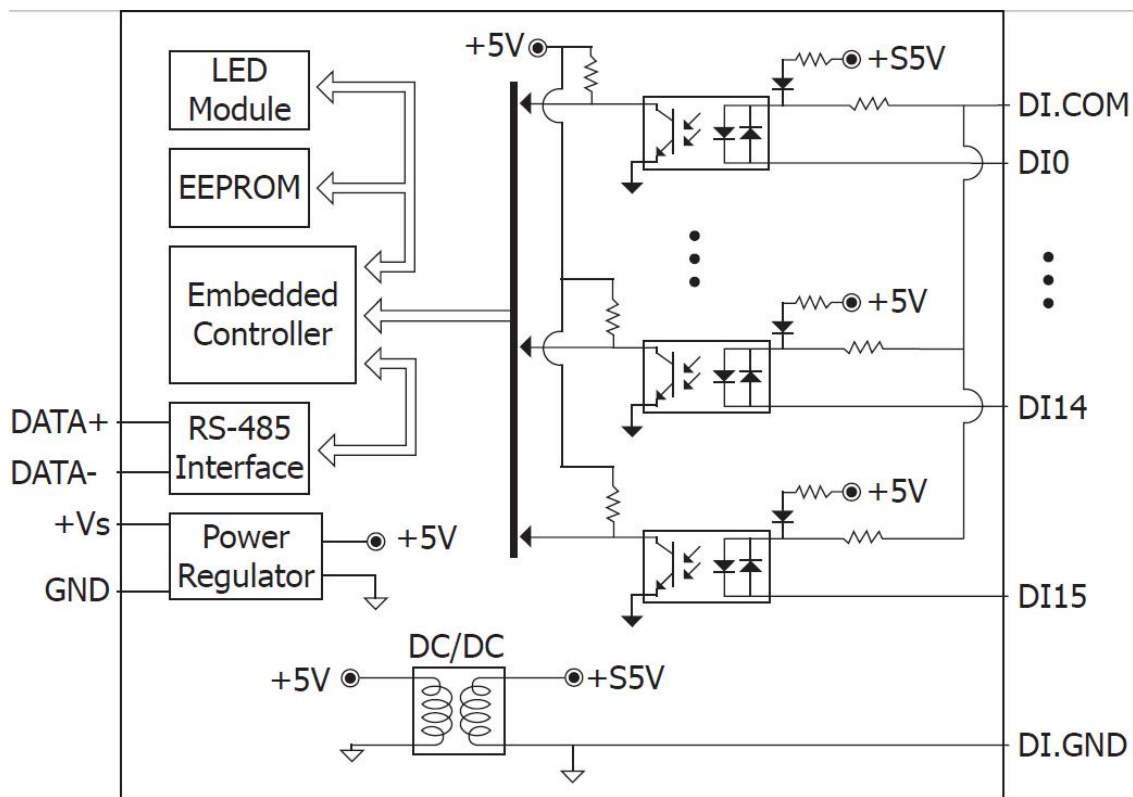

1.4.10 Block Diagram for the I-7052/52D and M-7052/52D

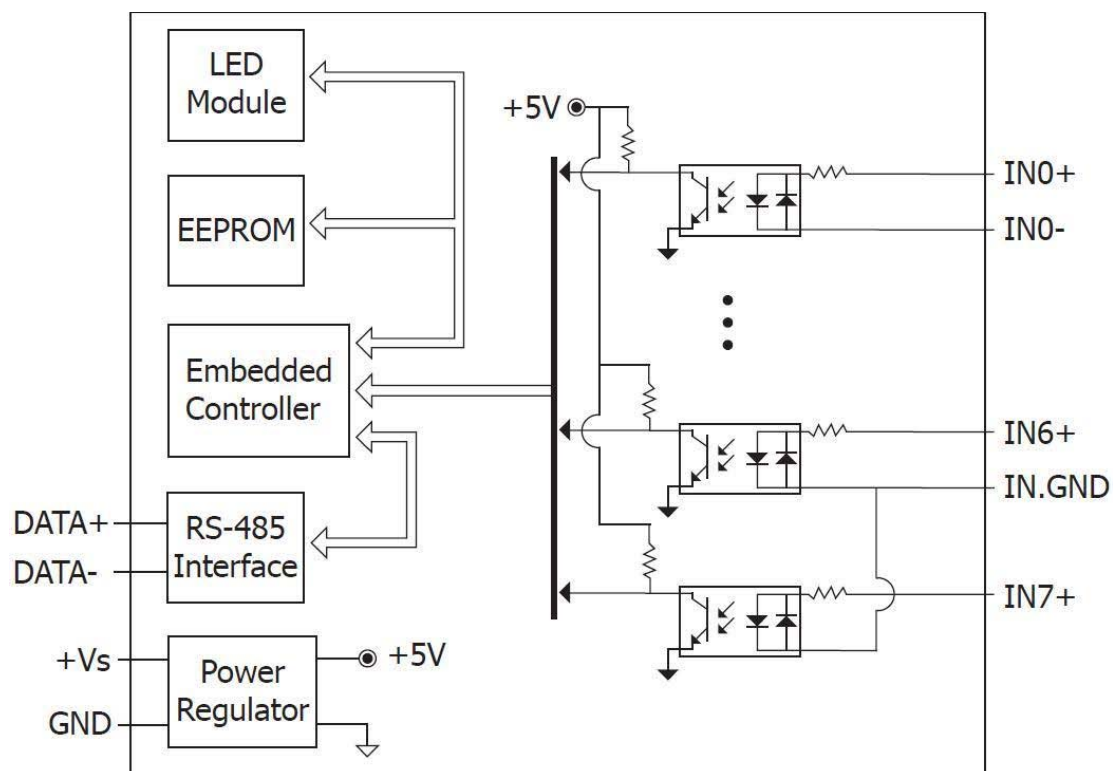

1.4.11 Block Diagram for the I-7053_FG/53D_FG and M-7053/53D

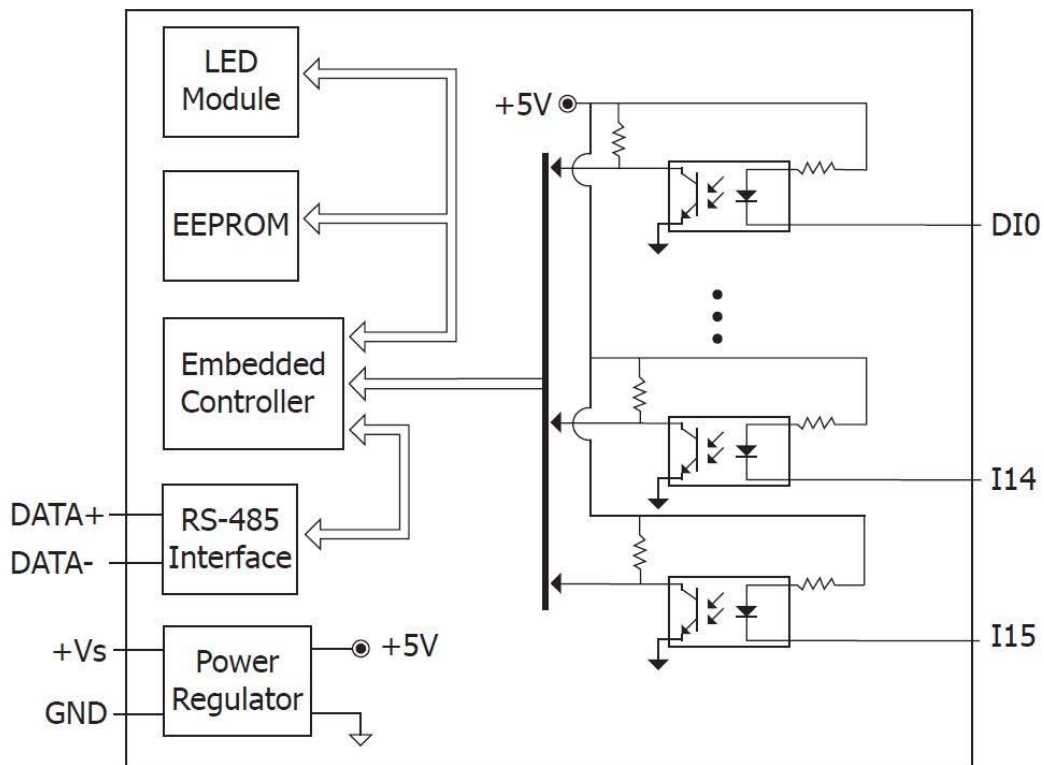

1.4.12 Block Diagram for the I-7055/55D and M-7055/55D

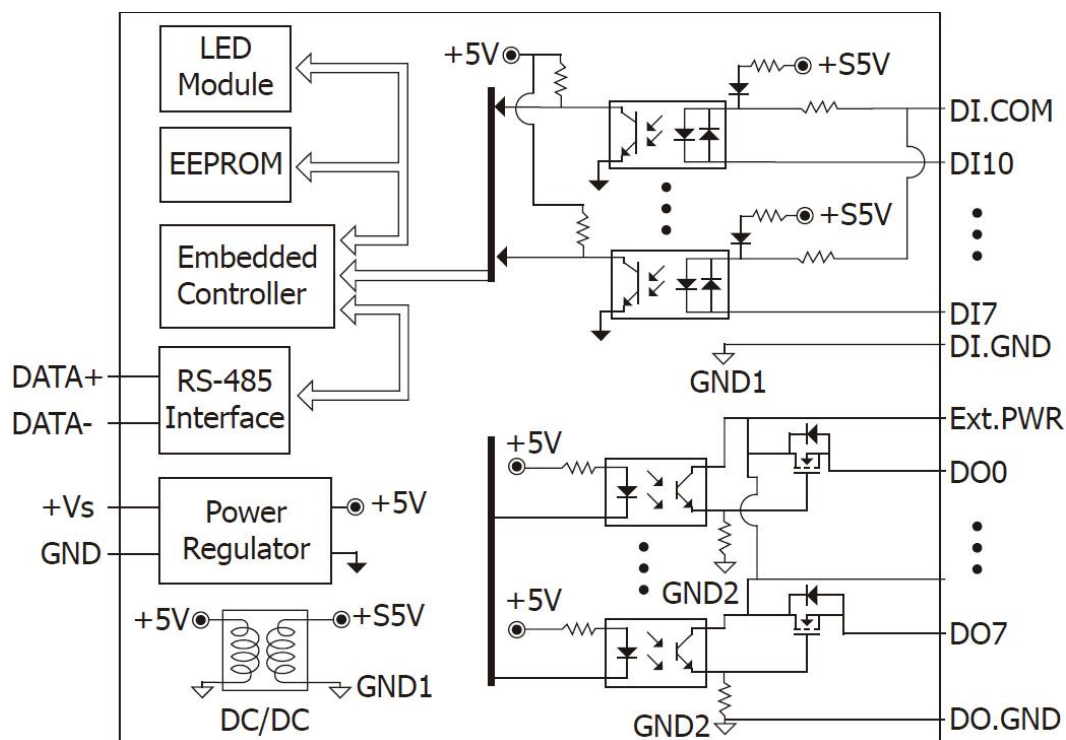

1.4.13 Block Diagram for the I-7055-NPN/55D-NPN and M-7055-NPN/55D-NPN

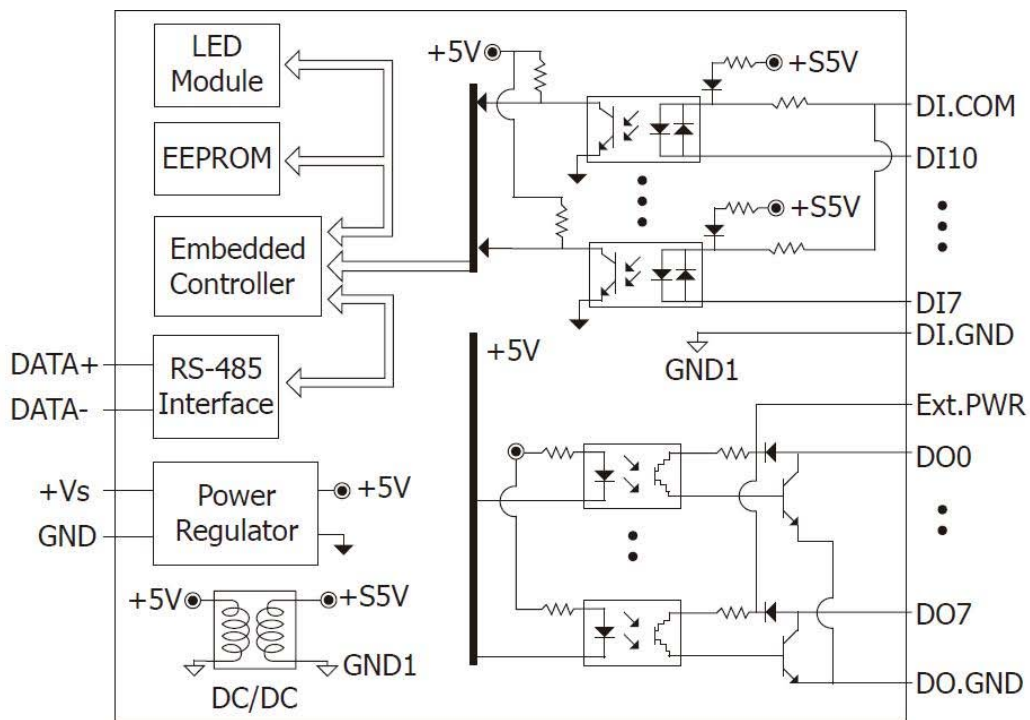

1.4.14 Block Diagram for the I-7058/58D and M-7058/58D

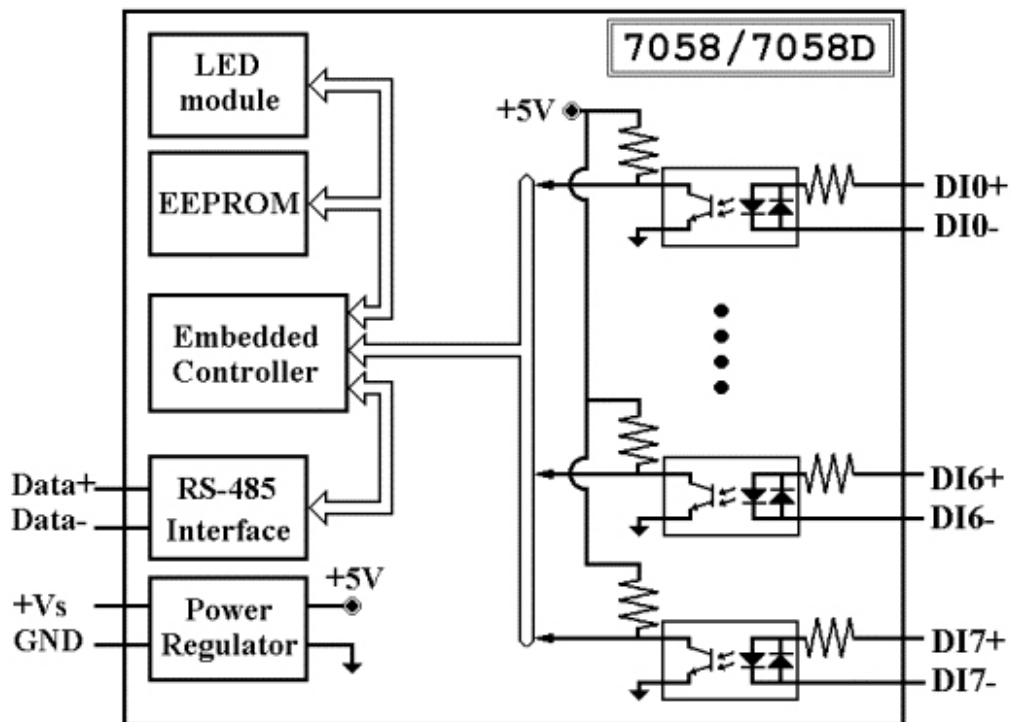

1.4.15 Block Diagram for the I-7059/59D and M-7059/59D

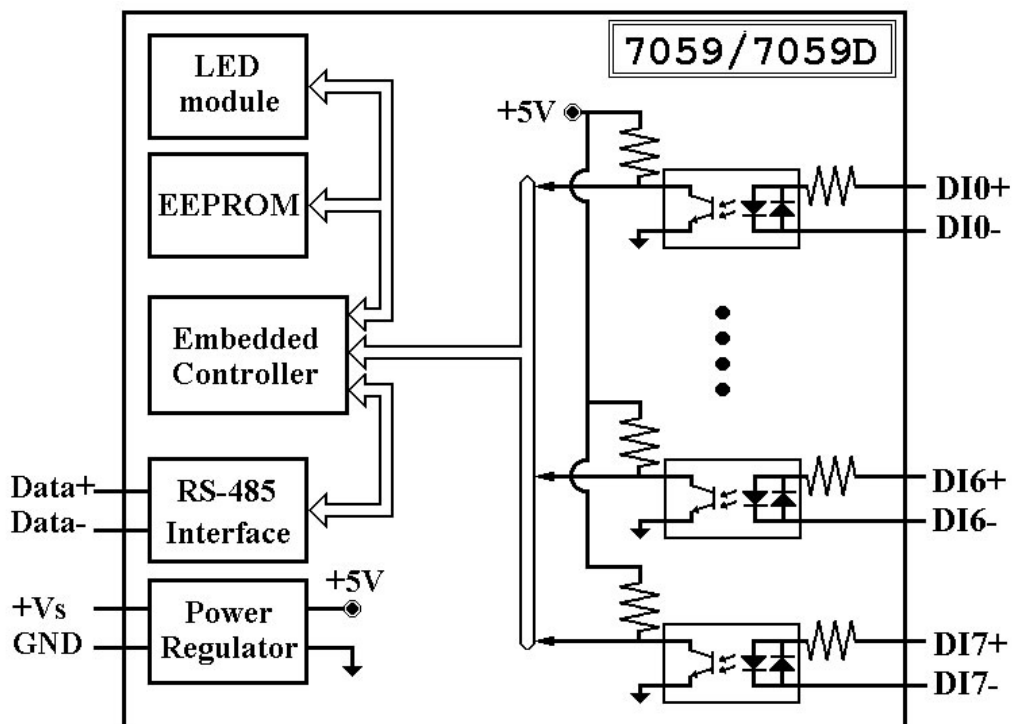

1.4.16 Block Diagram for the I-7060/60D, M-7060/60D, and M-7060P

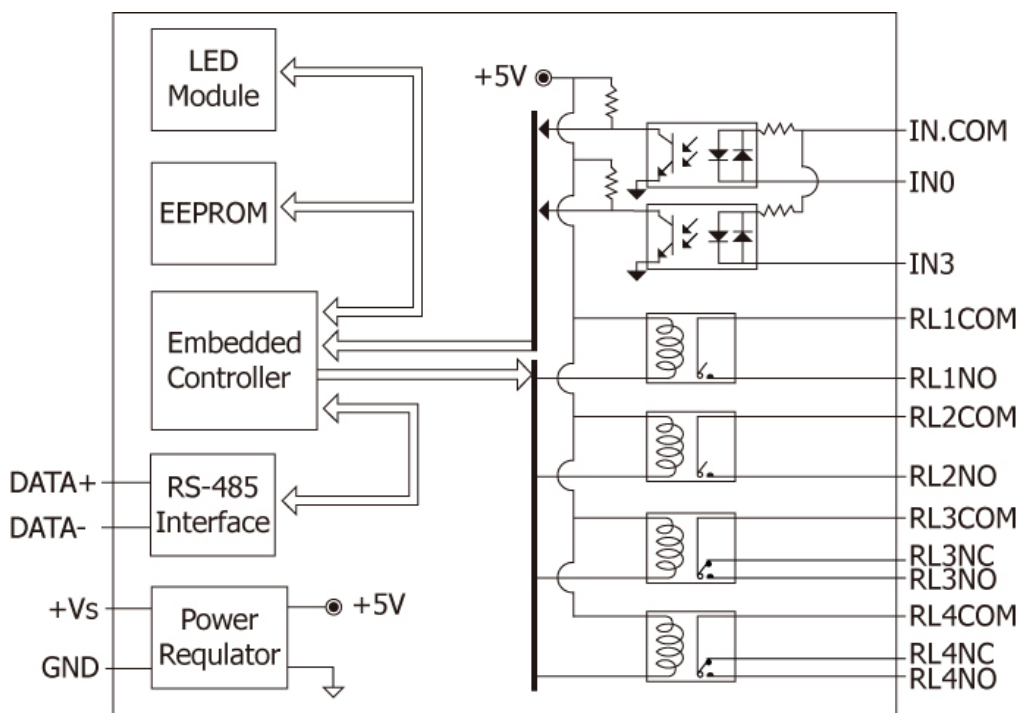

1.4.17 Block Diagram for the I-7061/61D and M-7061/61D

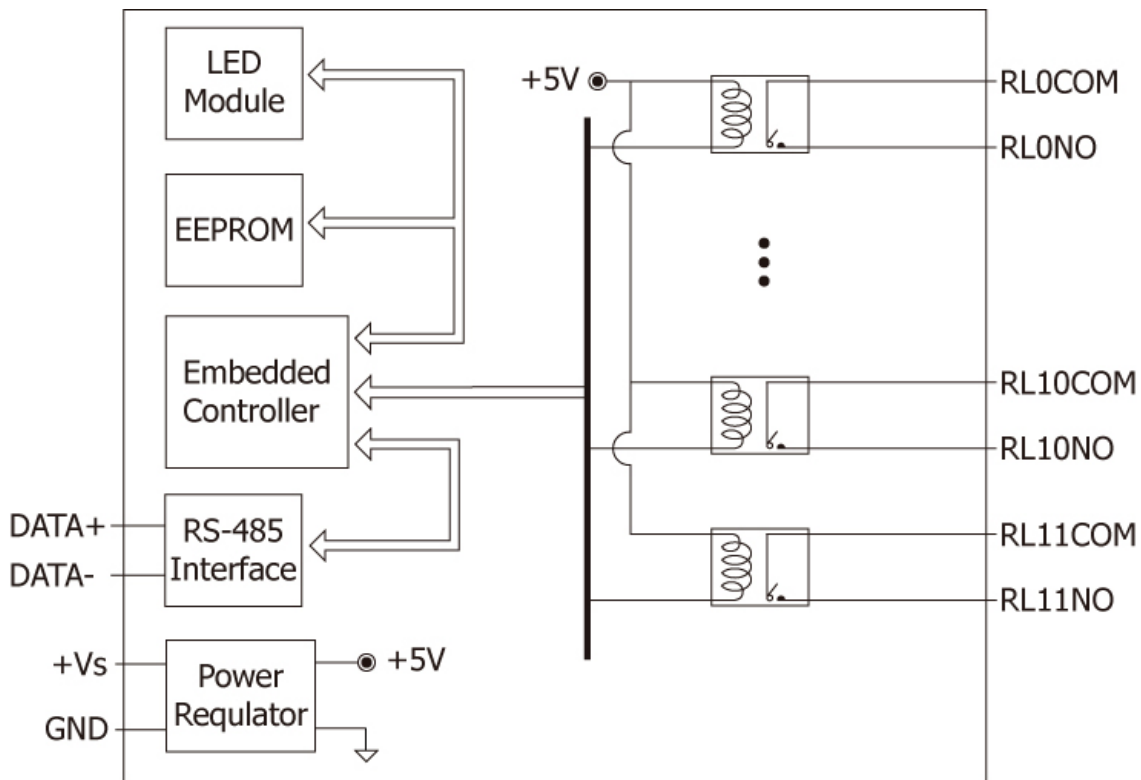

1.4.18 Block Diagram for the I-7063/63D

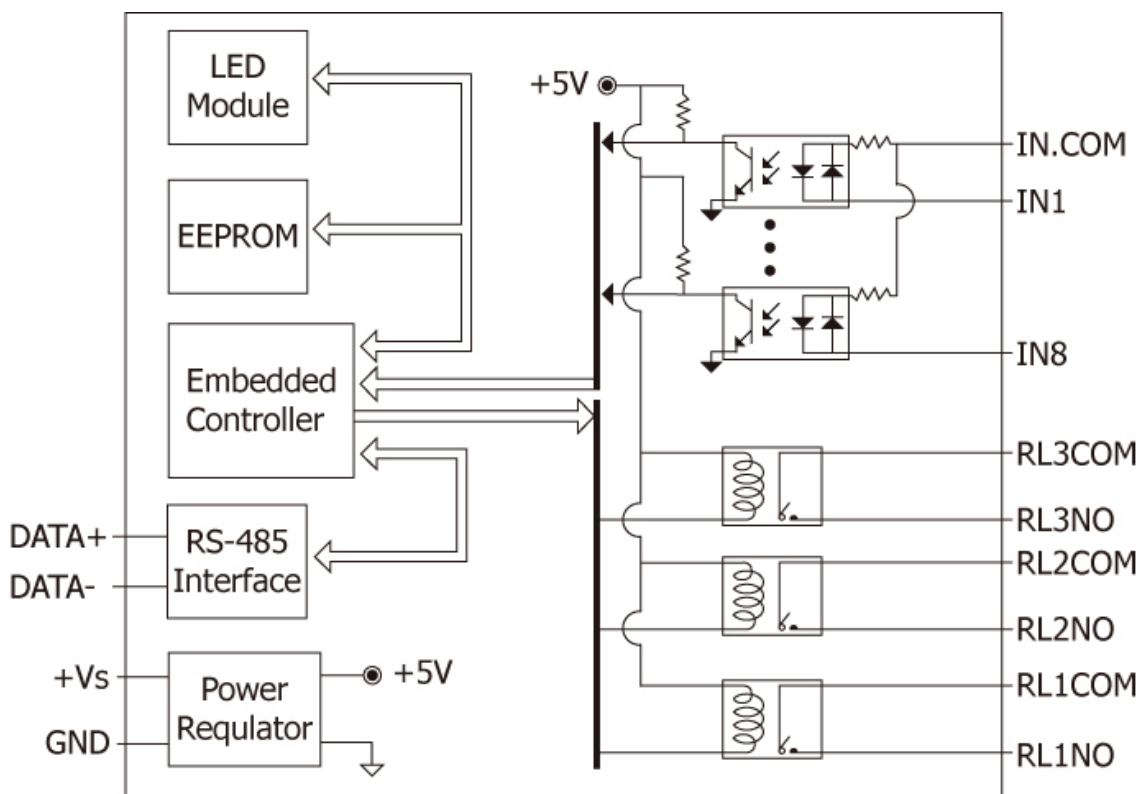

1.4.19 Block Diagram for the I-7063A/63AD

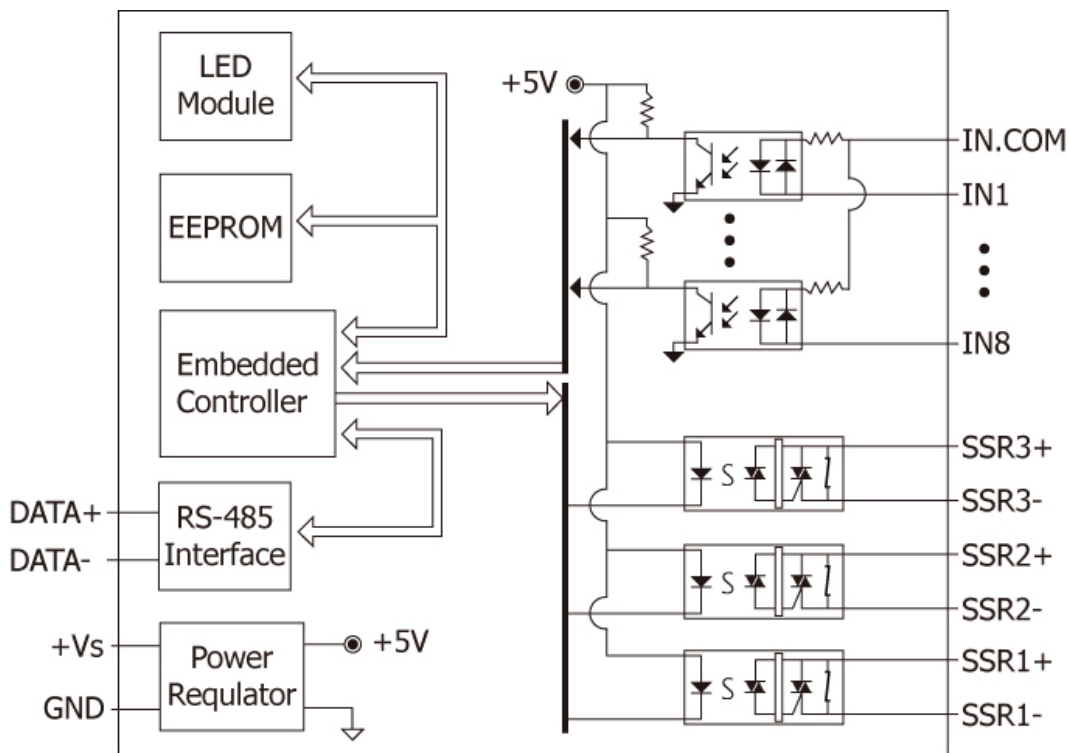

1.4.20 Block Diagram for the I-7063B/63BD

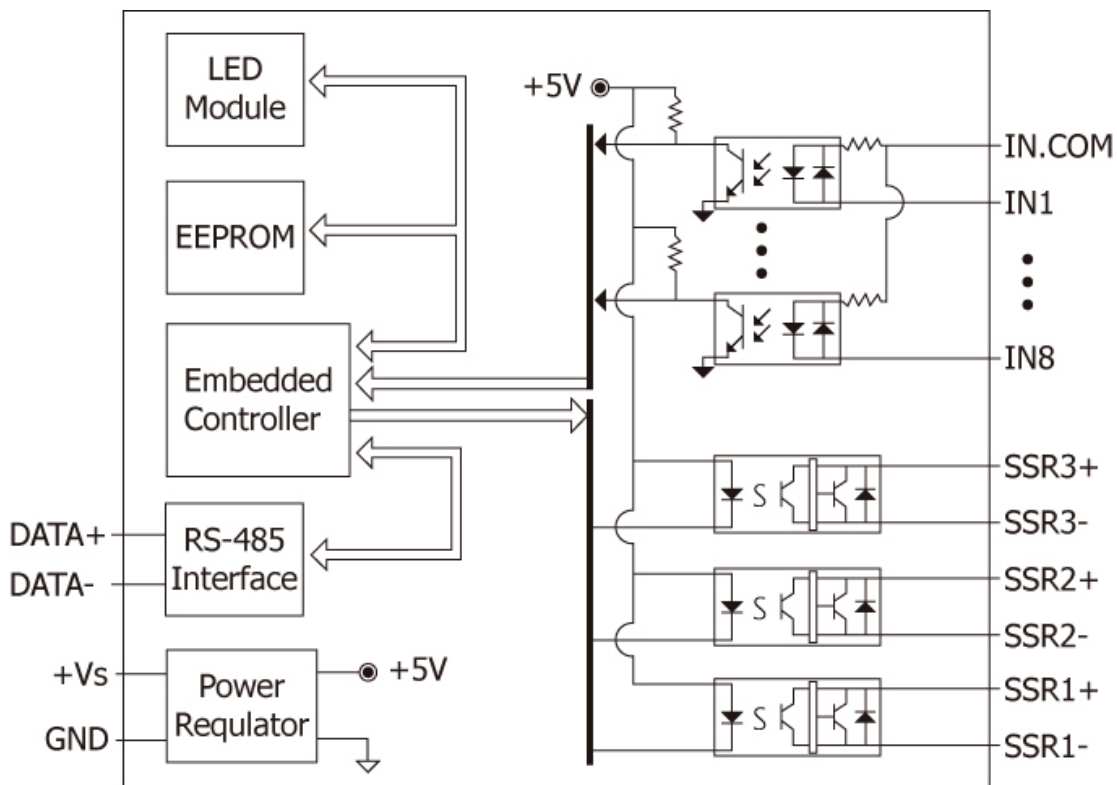

1.4.21 Block Diagram for the I-7065/65D

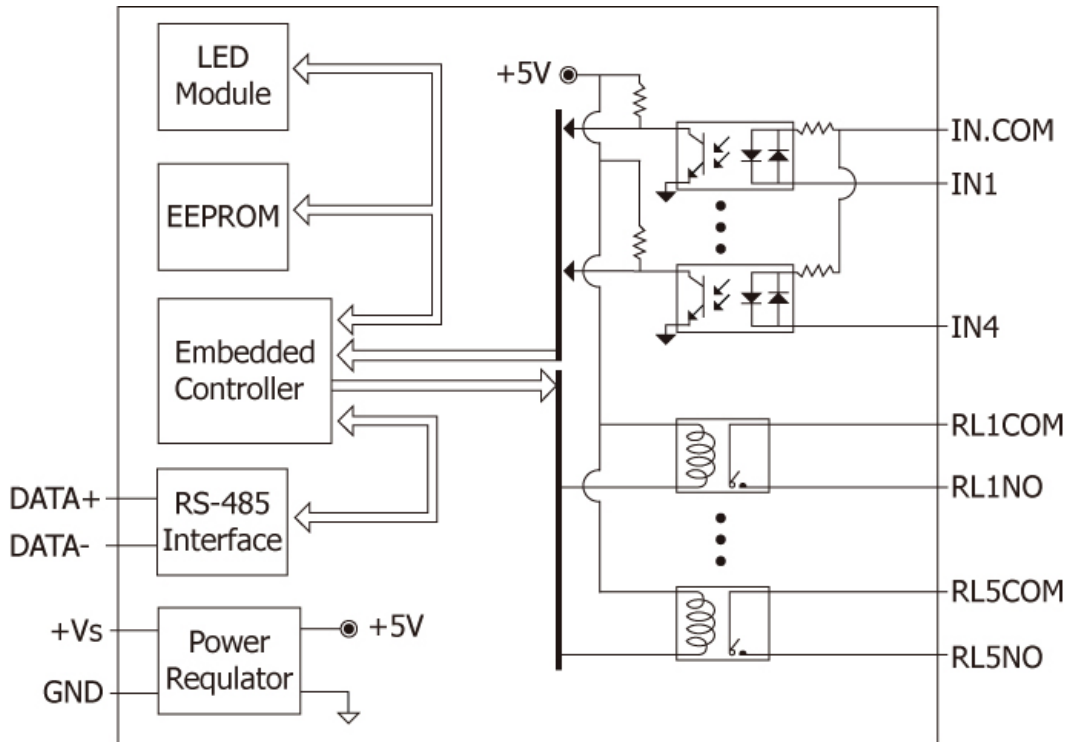

1.4.22 Block Diagram for the I-7065A/65AD

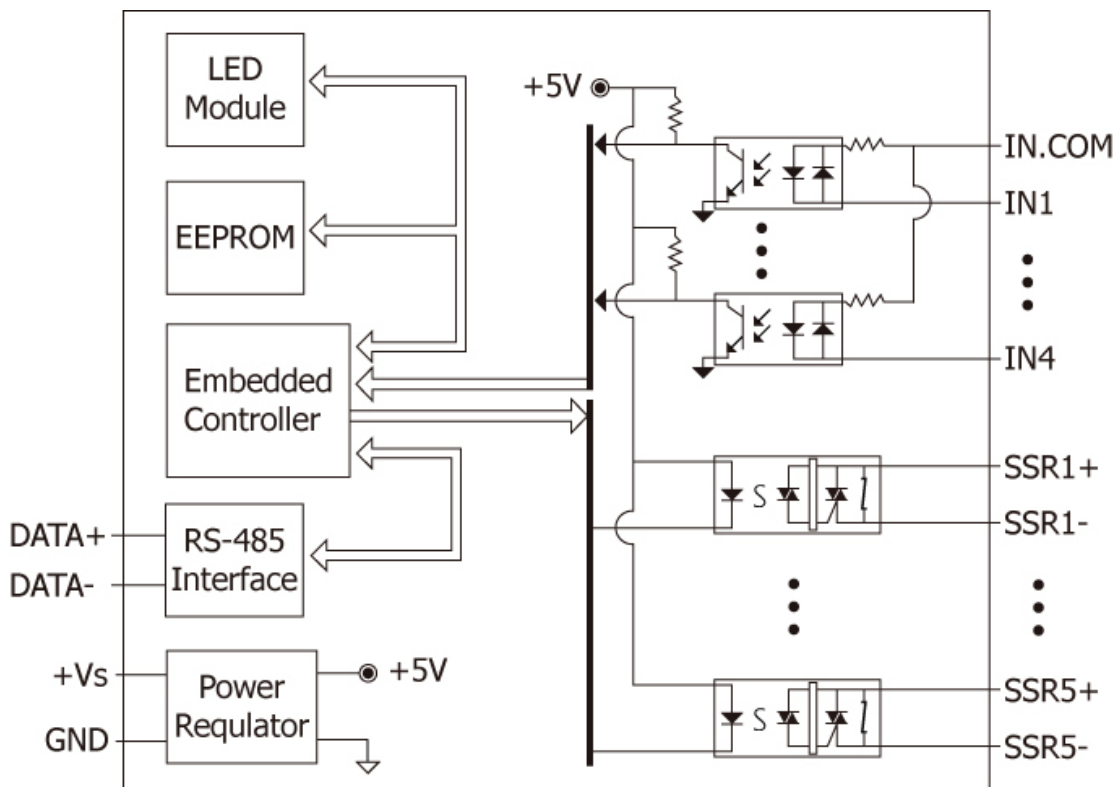

1.4.23 Block Diagram for the I-7065B/65BD

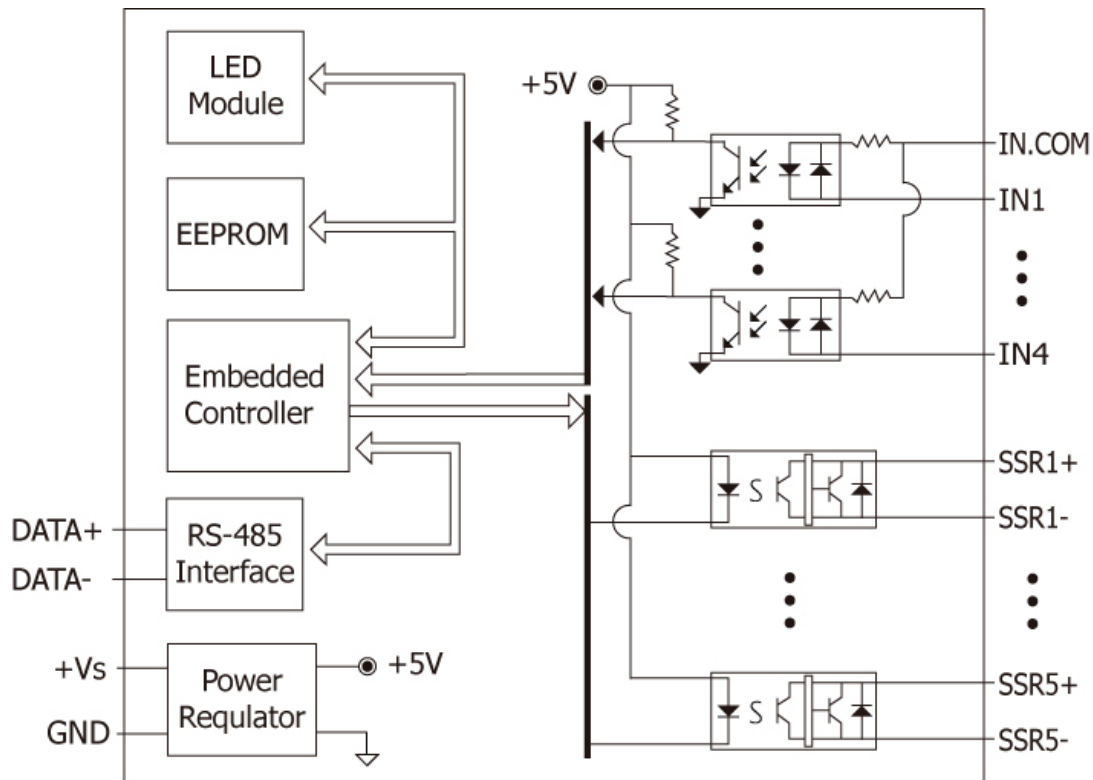

1.4.24 Block Diagram for the I-7066/66D

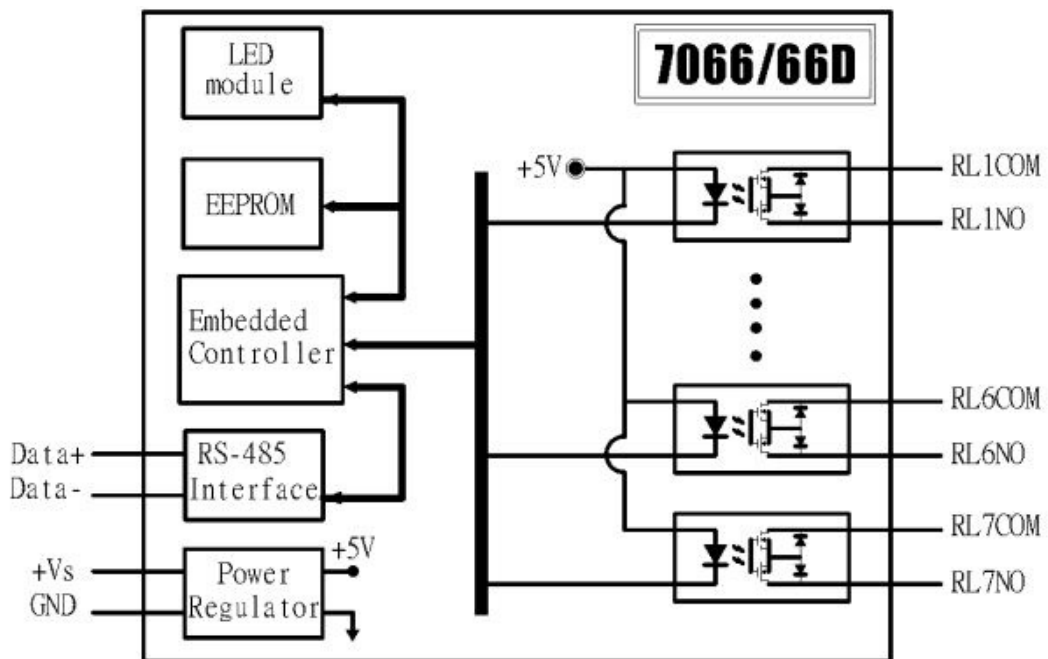

1.4.25 Block Diagram for the I-7067/67D and M-7067/67D

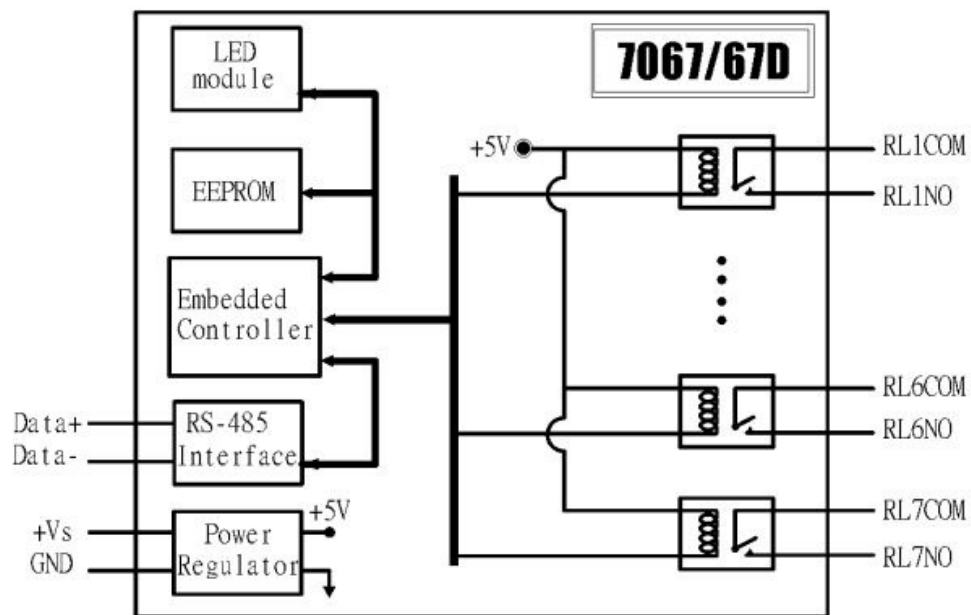

1.5 Dimensions

1.5.1 Modules without Frame Ground

The dimensions of the I-7041/41D, M-7041/41D, I-7042/42D, I-7043/43D, I-7044/44D, I-7050 series, M-7050 series, I-7052/52D, M-7052/52D, I-7060/60D, M-7060/60D, I-7063 series, I-7065 series, I-7066/66D, I-7067/67D and M-7067/67D are as shown below.

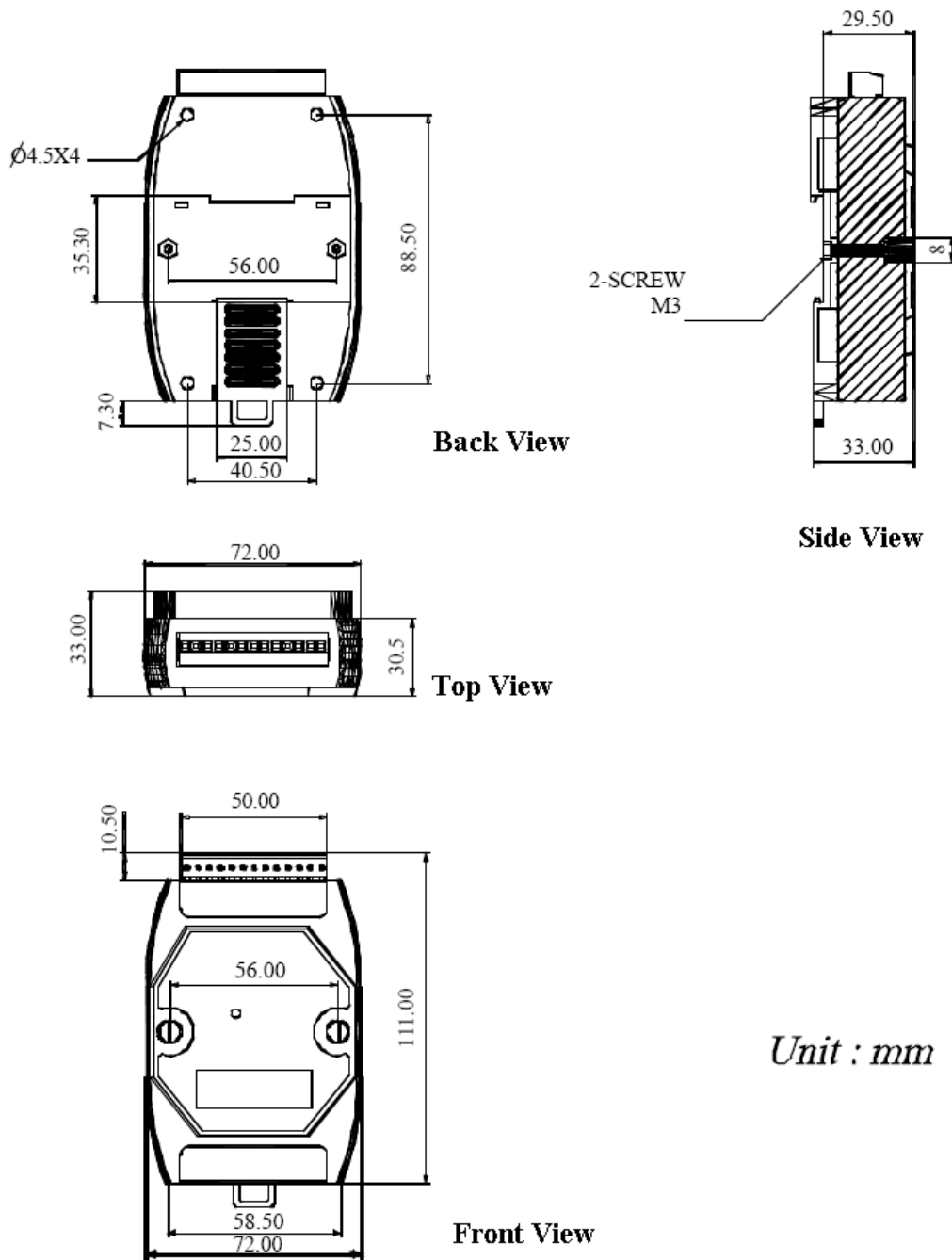

1.5.2 Modules with Frame Ground

The dimensions of the I-7045/45D, M-7045/45D, I-7051/51D, M-7051/51D, I-7053_FG/53D_FG, M-7053/53D, I-7055/55D, M-7055/55D, I-7058/58D, I-7059/59D and M-7060P are as shown below.

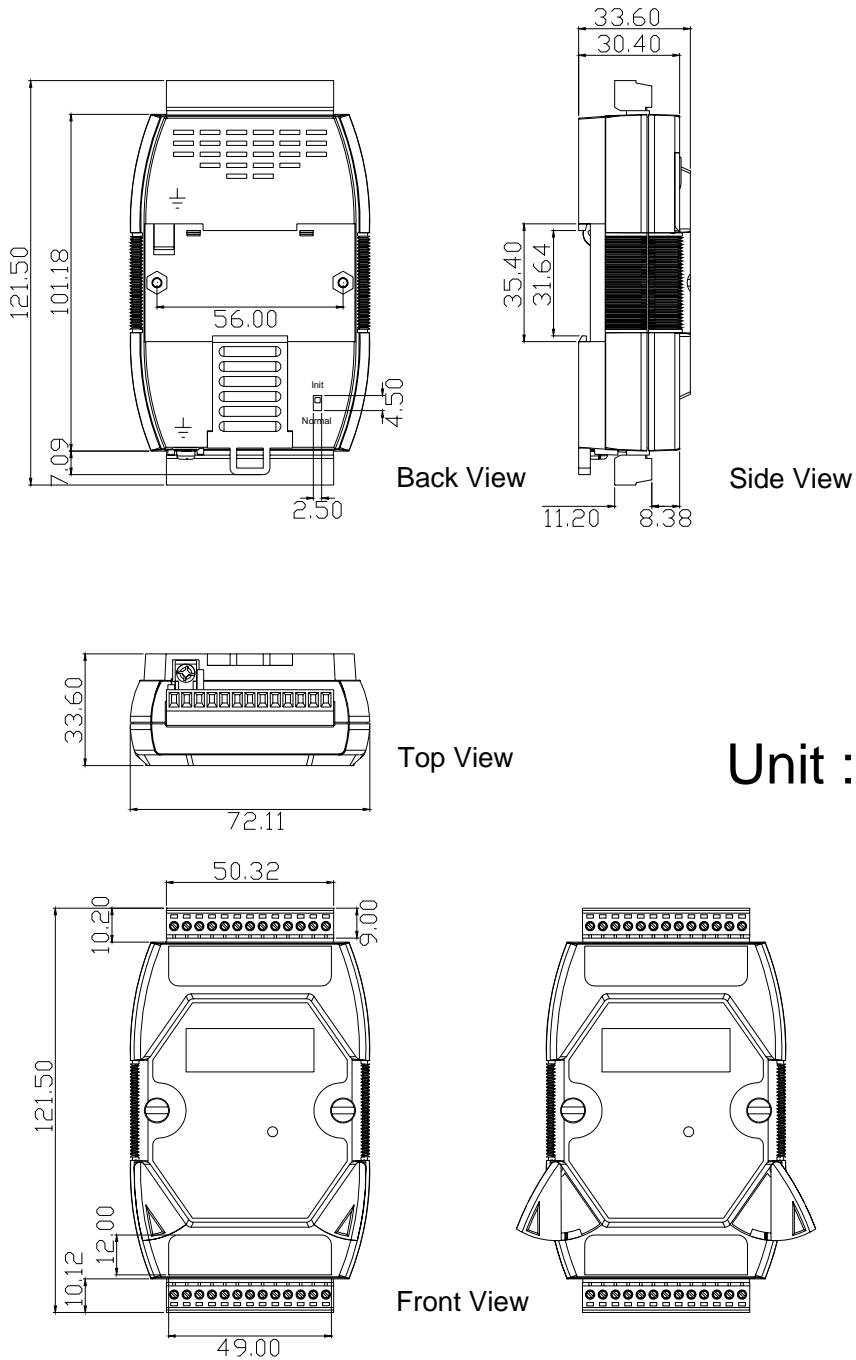

1.6 Wiring

1.6.1 I-7041/41D, I-7041P/41PD, M-7041/41D and M-7041P/41PD wiring

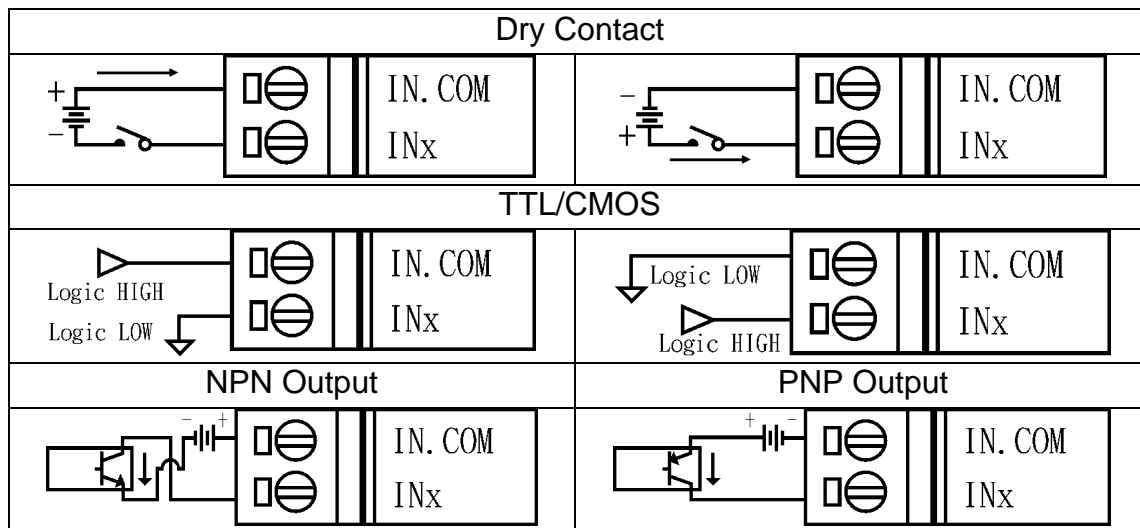

1.6.2 I-7042/42D wiring

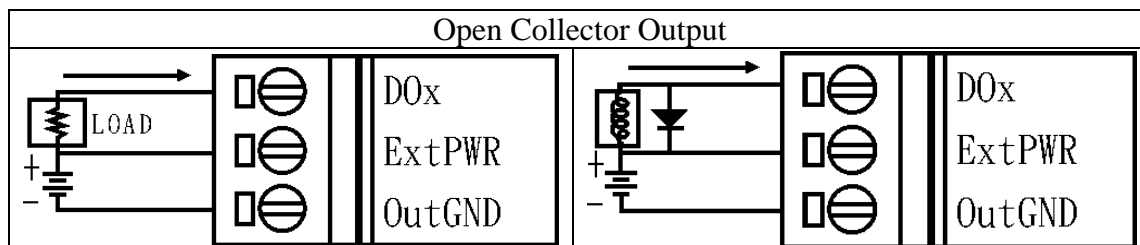

1.6.3 I-7043/43D wiring

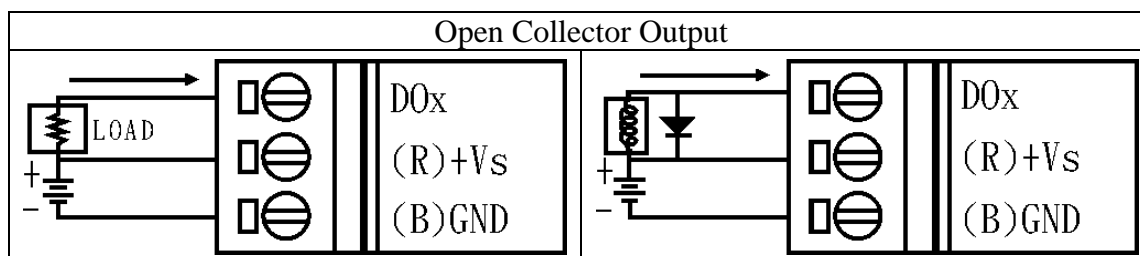

1.6.4 I-7044/44D wiring

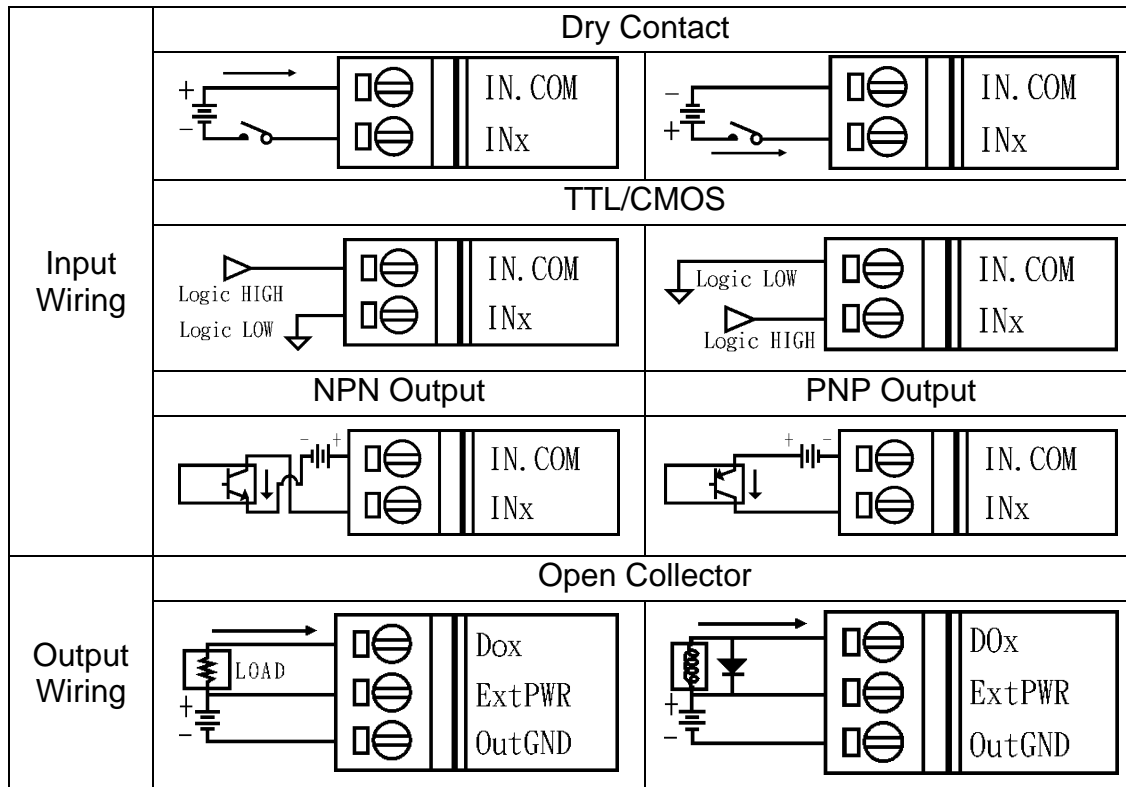

1.6.5 I-7045/45D and M-7045/45D wiring

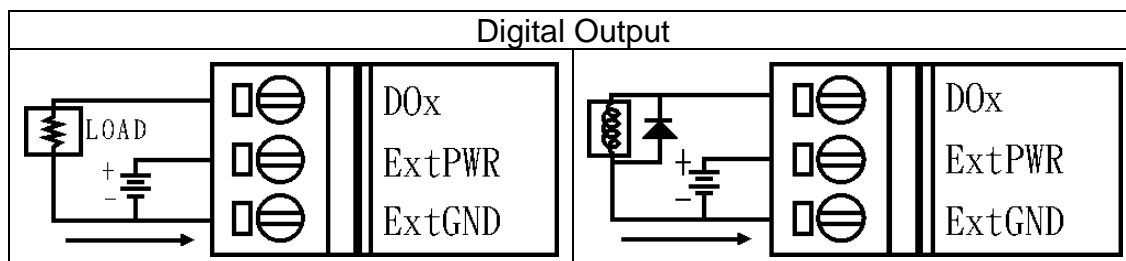

1.6.6 I-7045-NPN, I-7045D-NPN, M-7045-NPN and M-7045D-NPN wiring

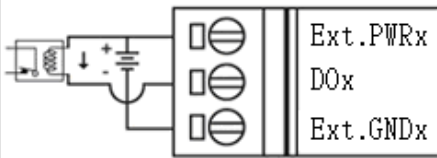
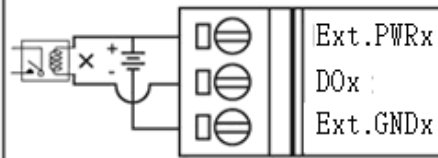
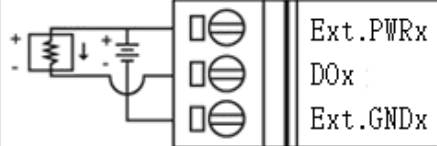
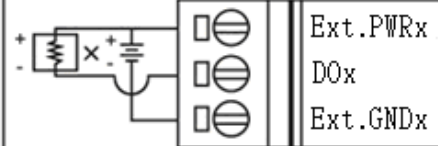
| Output Type | ON State LED ON Readback as 1 | OFF State LED OFF Readback as 0 |
|-----------------|---|--|
| | Relay ON | Relay Off |
| Drive Relay |  |  |
| Resistance Load |  |  |

1.6.7 I-7050/50D and M-7050/50D wiring

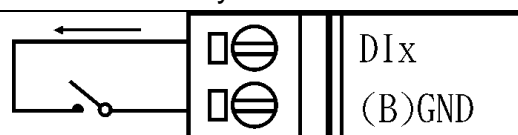
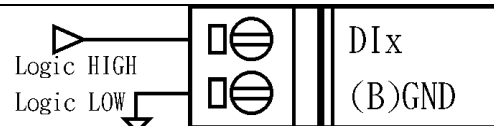
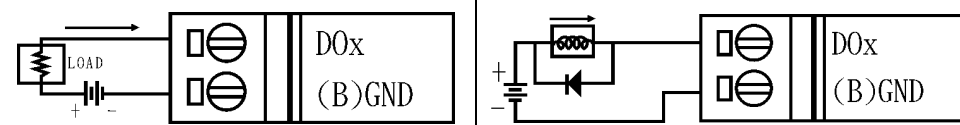
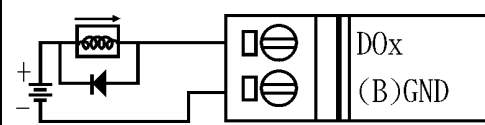
| | | |
|-------------|--|--|
| Input Type | Dry Contact | |
| |  | |
| | TTL/CMOS | |
| Input Type |  | |
| | Open Collector | |
| Output Type |  | |
| |  | |

1.6.8 I-7050A/50AD wiring

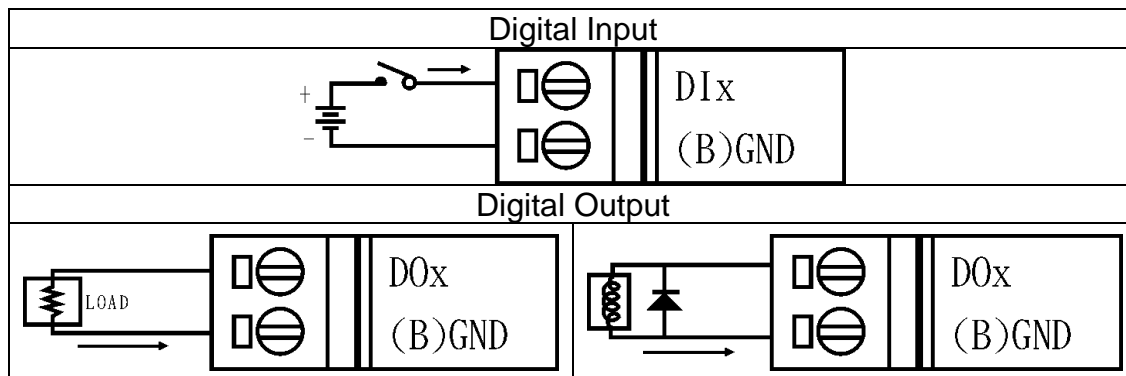

1.6.9 I-7051/51D and M-7051/51D wiring

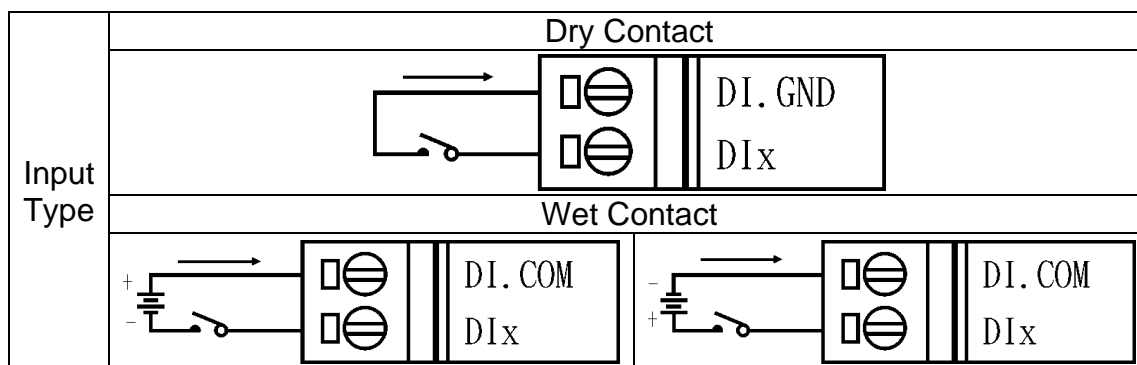

1.6.10 I-7052/52D and M-7052/52D wiring

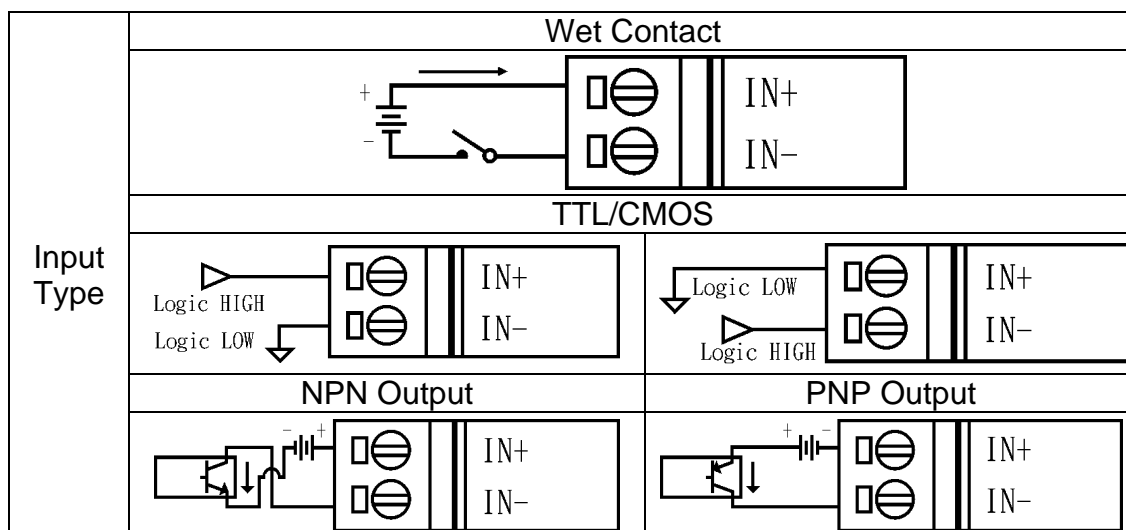

1.6.11 I-7053_FG/53D_FG and M-7053/53D wiring

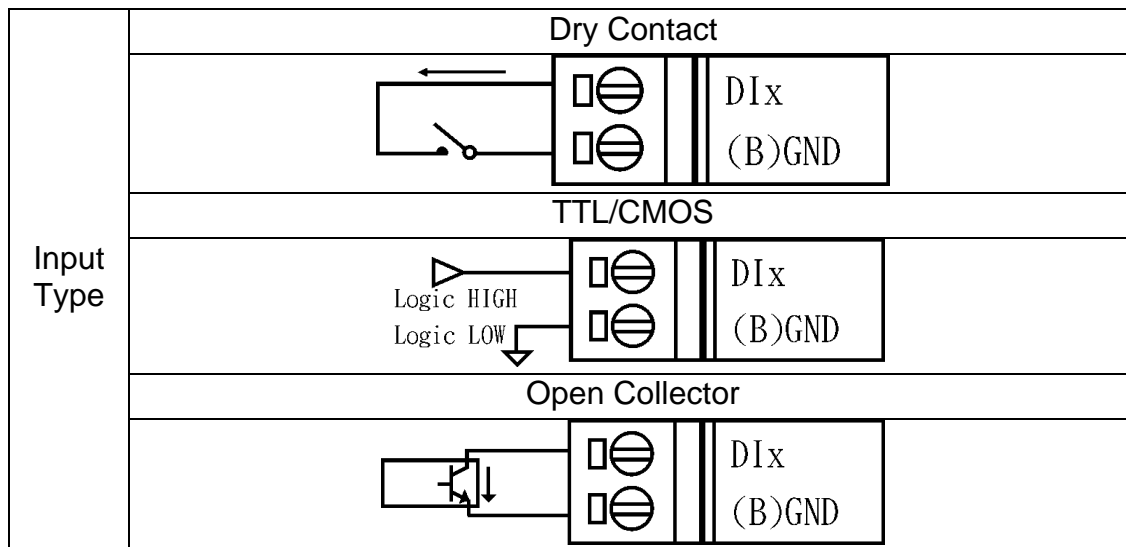

1.6.12 I-7055/55D and M-7055/55D wiring

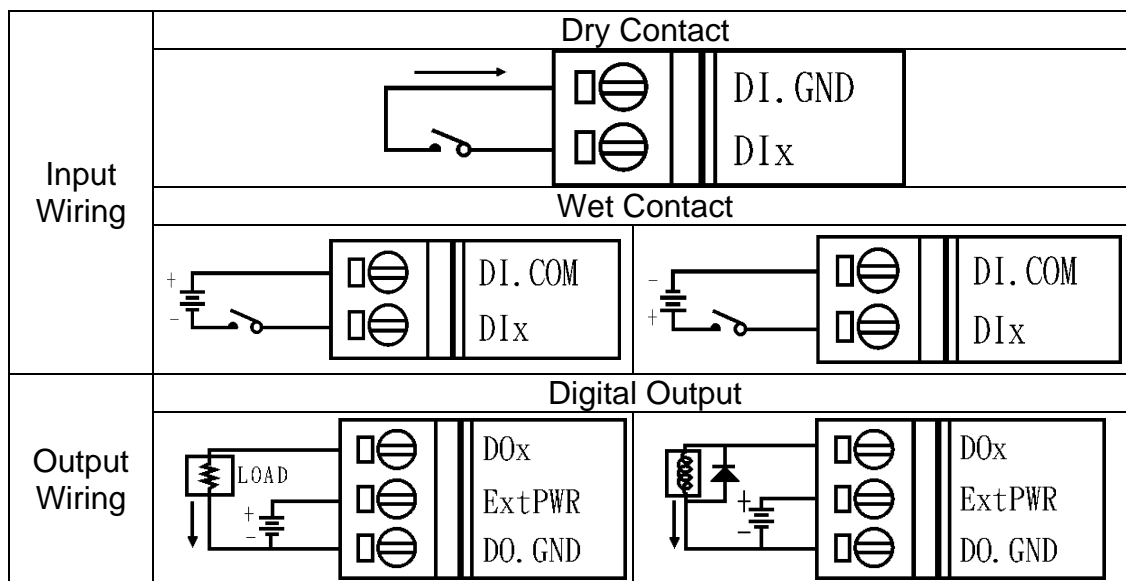

1.6.13 I-7055-NPN, I-7055D-NPN, M-7055-NPN and M-7055D-NPN wiring

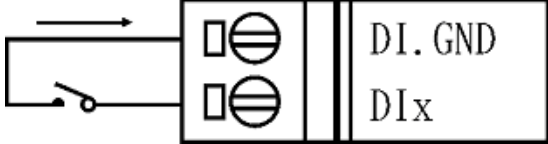
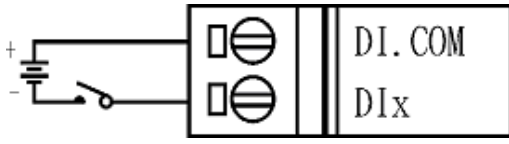
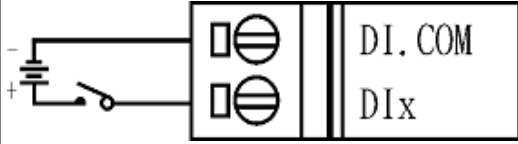
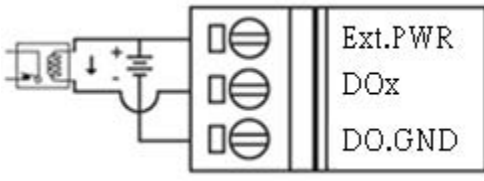
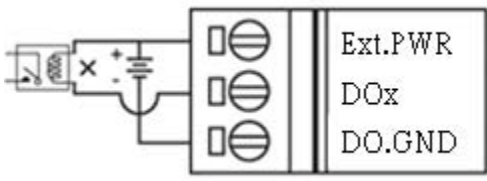
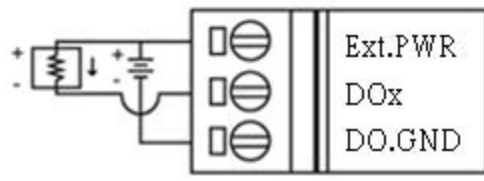
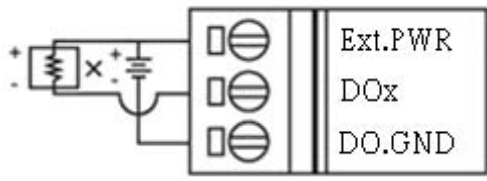
| | | |
|-----------------|---|--|
| Input Type | Dry Contact | |
| |  | |
| Output Type | Wet Contact | |
| |  |  |
| Drive Relay | ON State LED ON Readback as 1 Relay ON | OFF State LED OFF Readback as 0 Relay Off |
| |  |  |
| Resistance Load |  |  |

1.6.14 I-7058/58D, I-7059/59D, M-7058/58D and M-7059/59D wiring

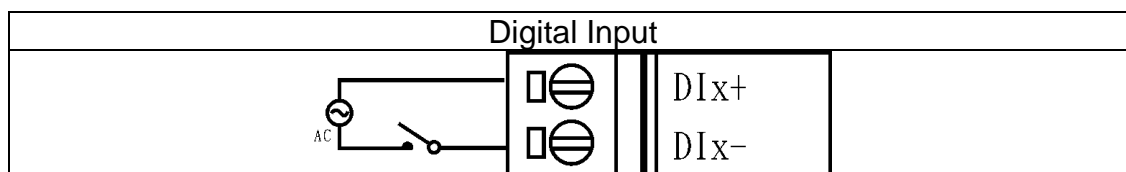

1.6.15 I-7060/60D and M-7060/60D wiring

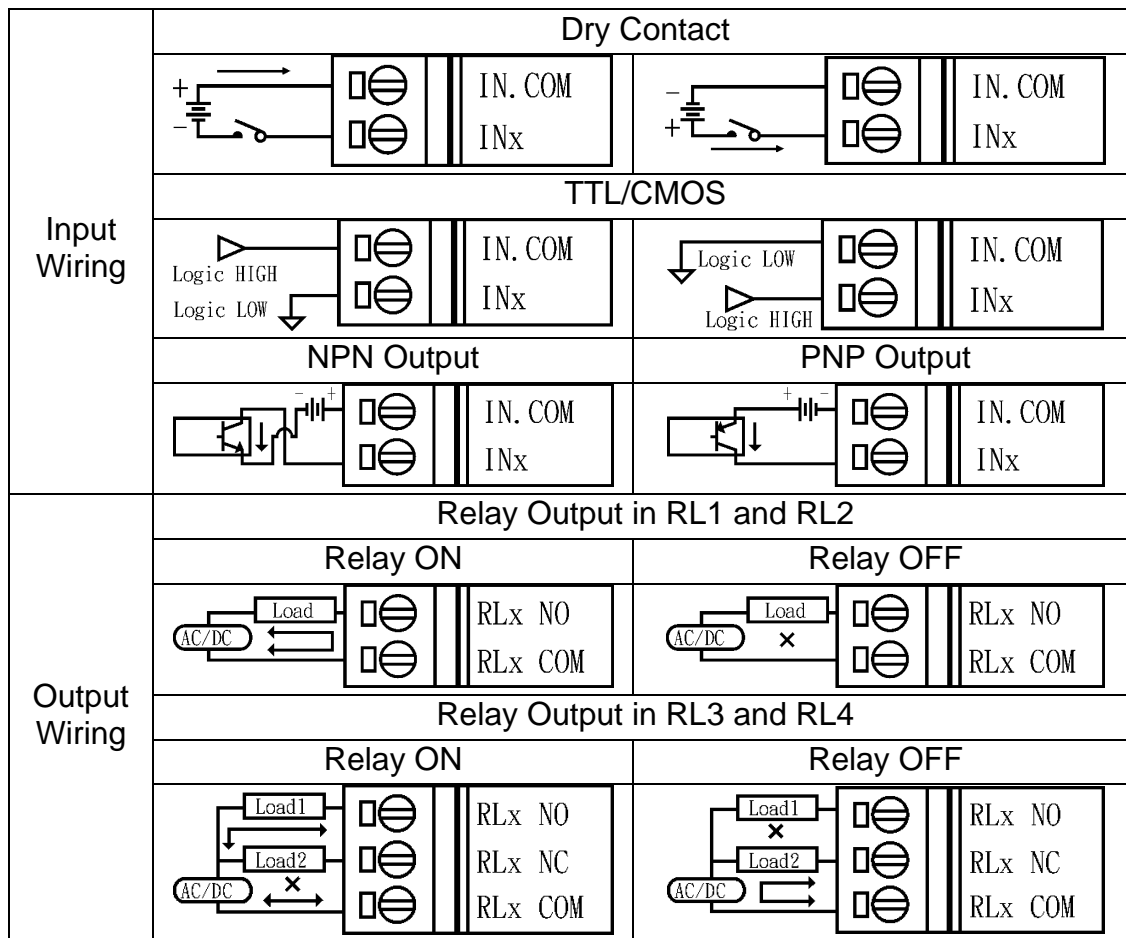

1.6.16 M-7060P wiring

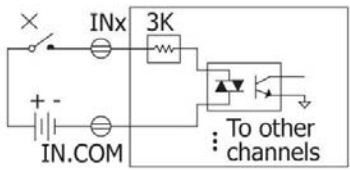
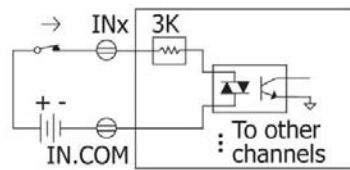
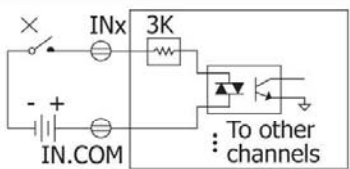
| Digital Input/ Counter | ON State Readback as 1 | OFF State Readback as 0 |
|---------------------------|---|---|
| Sink | OPEN or <1 Vdc  | +4 ~ +30 Vdc  |
| | Source | OPEN or <1 Vdc  |

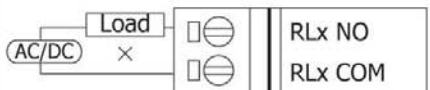
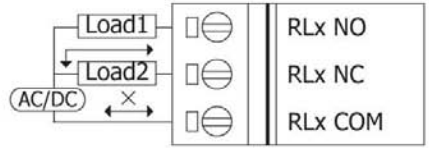
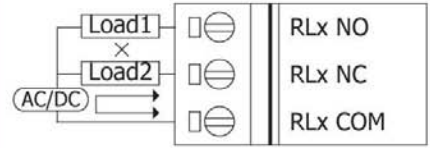
| Output Type | ON State Readback as 1 | OFF State Readback as 0 |
|--------------------------------|---|--|
| Relay Output in RL1 and RL2 |  |  |
| Relay Output in RL3 and RL4 |  |  |

1.6.17 I-7061/61D and M-7061/61D wiring

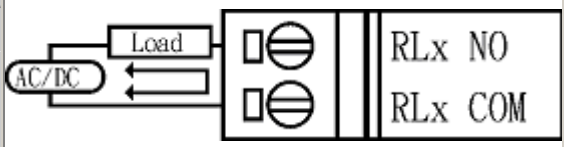
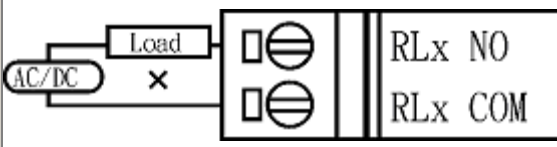
| Relay Output in RL1 and RL2 | | |
|-----------------------------|---|--|
| Output Type | Relay On | Relay Off |
| |  |  |

1.6.18 I-7063/63D, I-7063A/63AD, I-7063B/63BD, I-7065/65D, I-7065A/65AD and I-7065B/65BD wiring

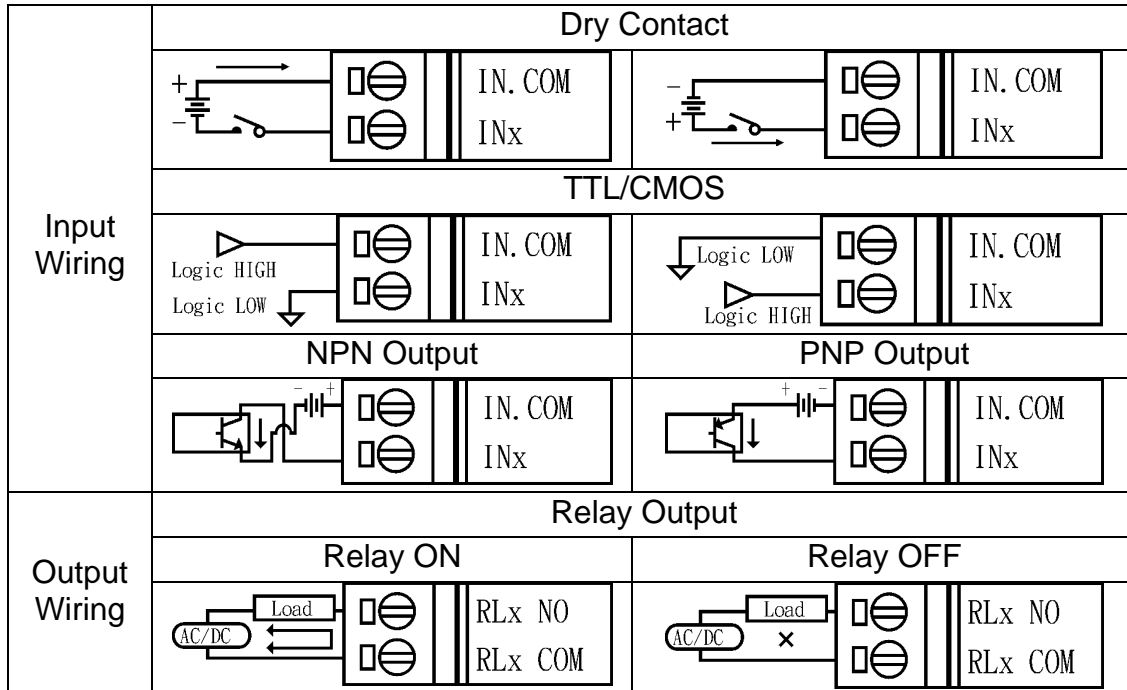

1.6.19 I-7066/66D, I-7067/67D and M-7067/67D wiring

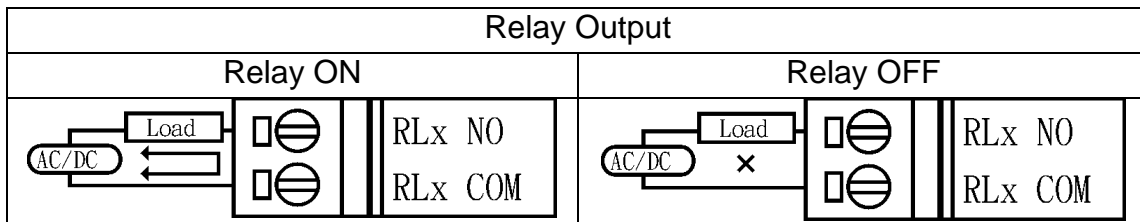

1.6.20 Wiring Recommendations

- Use 26-12 AWG wire for signal connections.
- Strip the wire to a length of 7 ± 0.5 mm.
- Use a crimp terminal for wiring.
- Avoid high-voltage cables and power equipment as much as possible.
- For RS-485 communication, use insulated and twisted pair 24 AWG wire, e.g. Belden 9841.



1.7 Jumper Setting

Note: To access the jumper, the cover must be opened.

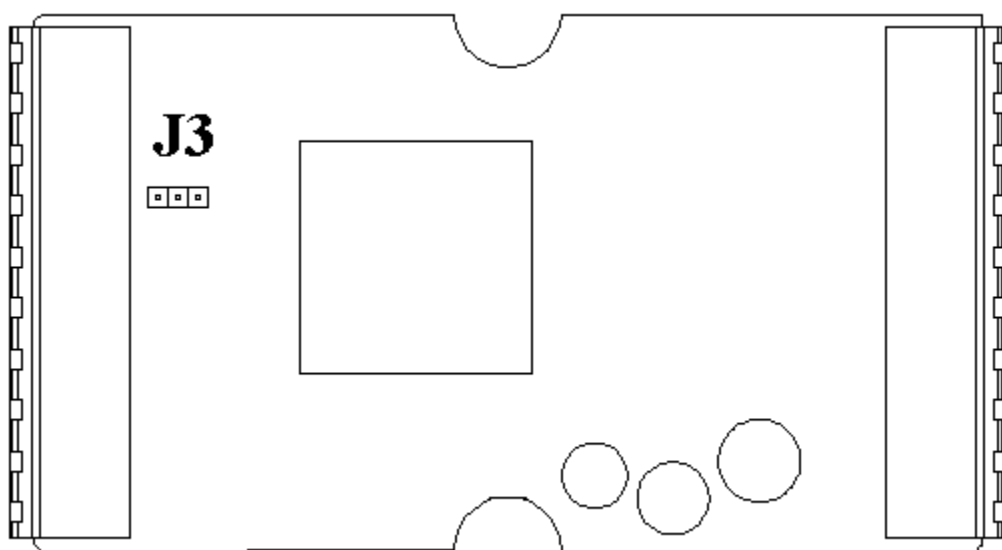
For the I-7043 and I-7043D modules, the INIT* terminal is shared with the DO15 terminal. The functionality of the terminal is set using the J3 jumper. The position of the J3 jumper is shown in the figure below.



The settings for the J3 jumper are as follows.

| | | |
|-----------|---|---|
| J3 |  | Terminal INIT*/DO15 is set to INIT*. The digital output channel 15 is disabled and INIT mode is available. (factory default) |
| J3 |  | Terminal INIT*/DO15 is set to DO15. The digital output channel 15 is enabled and INIT mode is not available. |

1.8 Quick Start

To install the module, follow the steps below:

1. Refer to Section 1.2 for the terminal assignment and Section 1.6 for the wiring diagram.
2. Connect the module to the RS-485 network using the DATA+ and DATA- terminals. See Section 1.2 for the terminal assignment. If the host is only equipped with an RS-232 interface, then an RS-232 to RS-485 converter will be required. Refer to the “**I-7000 Bus Converter User’s Manual**” for more information.
3. Connect the module to the power supply using the +Vs and GND terminals. See Section 1.2 for the terminal assignment. Note that the voltage supplied to the module should be in the range of +10 to +30 VDC.
4. Configure the module by sending the %AANNTTCCFF command. See Section 2.1 for details. For M-7000 modules using the Modbus RTU protocol, configure the module using the following functions.
 - Sub-function 04h of Function 46h, see Section 3.7.2
 - Sub-function 06h of Function 46h, see Section 3.7.4The default settings for the module can be found in Section 1.9.
5. To read data from the input channels, send either the \$AA6 or @AA commands to the module. See Sections 2.13 and 2.21 for details. For M-7000 modules using the Modbus RTU protocol, use Function 02h to read the data from the input channels. See Section 3.2 for details.
6. To write data to the output channels, send the @AA(data) command to the module. See Section 2.22 for details. Refer to Sections 2.3 ~ 2.8 for other setting digital output commands. For M-7000 modules using the Modbus RTU protocol, use Function 05h or 0Fh to write the data to the output channels. See Sections 3.5 and 3.6 for details.

7. If the host is a PC with a Windows operating system installed, the DCON Utility can be used to allow easy configuration and reading of data. The DCON Utility can be downloaded from the ICP DAS website (<http://www.icpdas.com>). The documentation for the DCON Utility can be found in the "**Getting Started For I-7000 Series Modules**" manual.

Please refer to the "**I-7000 Bus Converter User's Manual**" and "**Getting Started For I-7000 Series Modules**" manuals for more details. The "**Getting Started For I-7000 Series Modules**" manual can be downloaded from the ICP DAS website (<http://www.icpdas.com>).

1.9 Default Settings

Default settings for the I-7000 DIO modules are as follows:

- Module Address: 01
- DIO Type: Type 40
- Baud Rate: 9600 bps
- Checksum disabled
- J3 set to INIT mode enabled for I-7043/43D.

Default settings for the M-7000 DIO modules are as follows:

- Protocol: Modbus RTU
- Module Address: 01
- DIO Type: Type 40
- Baud Rate: 9600 bps

1.10 Configuration Tables

Baud Rate Setting (CC)

| | | | | | | | | |
|-----------|------|------|------|------|-------|-------|-------|--------|
| Code | 03 | 04 | 05 | 06 | 07 | 08 | 09 | 0A |
| Baud rate | 1200 | 2400 | 4800 | 9600 | 19200 | 38400 | 57600 | 115200 |

Note: The data bits are fixed at one start bit, eight data bits, no parity and one stop bit for both the I-7000 and M-7000 series.

Type Setting (TT)

For I-7000 and M-7000 DIO modules, the type code is fixed to 40.

Data Format Setting (FF)

| | | | | | | | |
|----|----|----------|---|---|----|---|---|
| 7 | 6 | 5 | 4 | 3 | 2 | 1 | 0 |
| CU | CS | reserved | | | CD | | |

| Key | Description |
|-----|---|
| CD | Code I-7050: 0 (read only) I-7052: 2 (read only) I-7053: 3 (read only) I-7060: 1 (read only) For other modules, the code value can be changed by %AANN TTCCFF command and the default code value is 0. |
| CS | Checksum setting 0: Disabled 1: Enabled |
| CU | Counter update 0: The counter is updated when there is a falling edge in the input signal. 1: The counter is updated when there is a rising edge in the input signal. |

Note: The reserved bits should be zero.

Digital Input/Output Data Format Table

The data format of the response of the \$AA4, \$AA6 and \$AALS commands is: **(the First Data)(the Second Data)00**.

The data format of the response of the @AA command is: **(the First Data)(the Second Data)**.

Note: both the First Data and the Second Data are in two hexadecimal digits format.

| Module | The First Data | | The Second Data | |
|---------------|----------------|---------|-----------------|---------|
| I-7041Series | DI8 ~ DI13 | 00 ~ 3F | DI0 ~ DI7 | 00 ~ FF |
| I-7042/42D | DO8 ~ DO12 | 00 ~ 1F | DO0 ~ DO7 | 00 ~ FF |
| I-7043/43D | DO8 ~ DO15 | 00 ~ FF | DO0 ~ DO7 | 00 ~ FF |
| I-7044/44D | DO1 ~ DO8 | 00 ~ FF | DI1 ~ DI4 | 00 ~ 0F |
| I-7045 Series | DO8 ~ DO15 | 00 ~ FF | DO0 ~ DO7 | 00 ~ FF |
| I-7050 Series | DO0 ~ DO7 | 00 ~ FF | DI0 ~ DI6 | 00 ~ 7F |
| I-7051/51D | DI8 ~ DI15 | 00 ~ FF | DI0 ~ DI7 | 00 ~ FF |
| I-7052/52D | DI0 ~ DI7 | 00 ~ FF | | 00 |
| I-7053/53D | DI8 ~ DI15 | 00 ~ FF | DI0 ~ DI7 | 00 ~ FF |
| I-7055 Series | DO0 ~ DO7 | 00 ~ FF | DI0 ~ DI7 | 00 ~ FF |
| I-7058/58D | DI0 ~ DI7 | 00 ~ FF | | 00 |
| I-7059/59D | DI0 ~ DI7 | 00 ~ FF | | 00 |
| I-7060/60D | DO1 ~ DO4 | 00 ~ 0F | DI1 ~ DI4 | 00 ~ 0F |
| I-7061/61D | DO8 ~ DO11 | 00 ~ 0F | DO0 ~ DO7 | 00 ~ FF |
| I-7063 Series | DO1 ~ DO3 | 00 ~ 07 | DI1 ~ DI8 | 00 ~ FF |
| I-7065 Series | DO1 ~ DO5 | 00 ~ 1F | DI1 ~ DI4 | 00 ~ 0F |
| I-7066/66D | DO1 ~ DO7 | 00 ~ 7F | | 00 |
| I-7067/67D | DO1 ~ DO7 | 00 ~ 7F | | 00 |

1.11 DIO Active States

The DIO read value of the I-7000 and M-7000 modules are as follows:

| | DIO | Inactive | Active |
|---|------|----------|--------|
| I-7041/M-7041 | 14DI | ON | OFF |
| I-7042 | 13DO | OFF | ON |
| I-7043 | 16DO | OFF | ON |
| I-7044 | 8DO | OFF | ON |
| | 4DI | ON | OFF |
| I-7045/M-7045 | 16DO | OFF | ON |
| I-7050/M-7050 | 8DO | OFF | ON |
| | 7DI | ON | OFF |
| I-7050A | 8DO | OFF | ON |
| | 7DI | OFF | ON |
| I-7051/M-7051 | 16DI | OFF | ON |
| I-7052/M-7052 | 8DI | OFF | ON |
| I-7053/M-7053 | 16DI | ON | OFF |
| I-7055/M-7055 | 8DO | OFF | ON |
| | 8DI | OFF | ON |
| I-7058/M-7058 | 8DI | OFF | ON |
| I-7059/M-7059 | 8DI | OFF | ON |
| I-7060/M-7060 | 4DO | OFF | ON |
| | 4DI | ON | OFF |
| I-7061/M-7061 | 12DO | OFF | ON |
| I-7063 | 3DO | OFF | ON |
| | 8DI | ON | OFF |
| I-7065 | 5DO | OFF | ON |
| | 4DI | ON | OFF |
| I-7066 | 7DO | OFF | ON |
| I-7067/M-7067 | 7DO | OFF | ON |
| ON means the DIO read value is 1. OFF means the DIO read value is 0. | | | |

1.12 M-7000 Notes

The main difference between the I-7000 and M-7000 series is that the M-7000 series has additional support for the Modbus RTU communication protocol, which is the default protocol of the M-7000 series. The communication Baud Rates for the Modbus RTU protocol can be in the range of 1200 bps to 115200 bps, and the parity, data and stop bits are fixed as no parity, 8 data bits and 1 stop bit.

Modbus functions supported by the module are described in Chapter 3.

1.12.1 Protocol Switching

To switch to the DCON protocol:

1. Uses sub-function 06h of the function 46h and set byte 8 to a value of 1. See Section 3.7.4 for details.
2. After a power-on reset, the communication protocol will be changed to DCON.

To switch to the Modbus RTU protocol:

1. Sends the \$AAPN command and set N to a value of 1. Note that for the modules without frame ground, the INIT* terminal should be connected to the GND terminal, and for the modules with frame ground, the slide switch on the rear side of the module should be set to the INIT position, see the figure on the next page. See Section 2.20 for details.
2. After a power-on reset, the communication protocol will be changed to the Modbus RTU protocol.

1.12.2 INIT Mode

When the module is powered on, with the rear slide switch set to the INIT position as shown in the figure below for modules with frame ground, or with the INIT* pin connected to the GND pin for modules without frame ground, the module is in INIT mode, (see Section A.1 for details), and the communication settings are as follows:

1. Address: 00
2. Baud Rate: 9600 bps
3. No checksum
4. Protocol: DCON

If communication with the module is not possible, set the module to the INIT mode and use the above settings to communicate with the module. To read the current settings, send the commands \$AA2, (see Section 2.10), and \$AAP, (see Section 2.19). To set new settings, send the commands %AANNTTCCFF, (see Section 2.1) and \$AAPN, (see Section 2.20). The new communication settings will be effective after the next power-on reset.

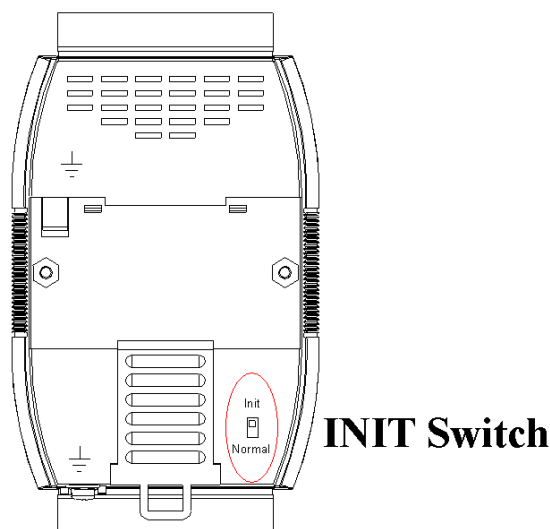

1.13 Mounting

1.13.1 Din-Rail Mounting

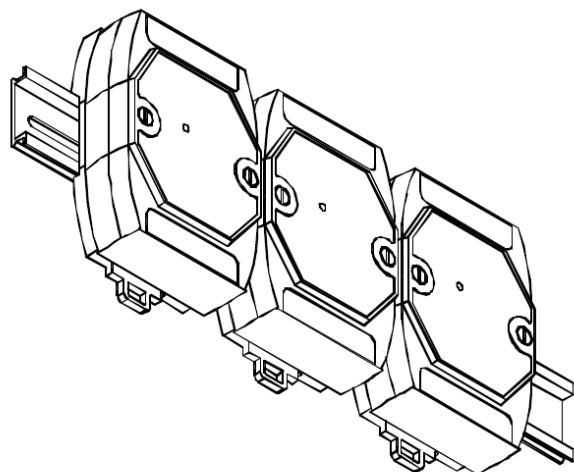

There are three new DIN rail models available. Each is made of stainless steel, which is stronger than those made of aluminum. There is a screw at one end and a ring terminal is included so that it can be easily connected to the earth ground. The three new DIN rail models are as follows.

| Part number | Max. number of modules | Dimensions |
|-------------|------------------------|--------------|
| DRS-360 | 5 | 360mm x 35mm |

to earth ground

The diagram shows a DIN rail with five modules mounted on it. A cable is connected to a ring terminal on the rail, with an arrow pointing downwards and the text "to earth ground" below it.

| Part number | Max. number of modules | Dimensions |
|-------------|------------------------|--------------|
| DRS-240 | 3 | 240mm x 35mm |

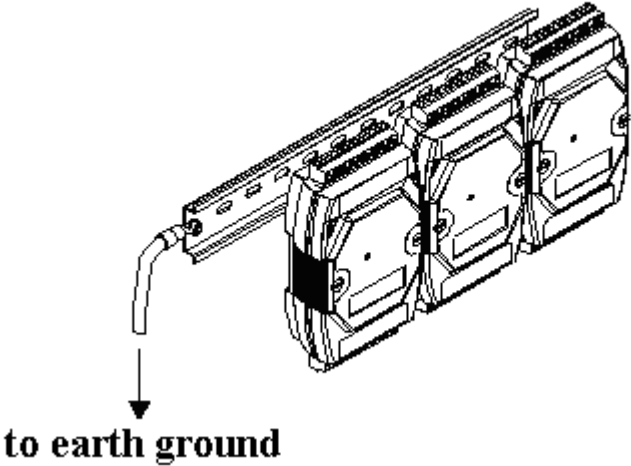

| Part number | Max. number of modules | Dimensions |
|-------------|------------------------|--------------|
| DRS-125 | 2 | 125mm x 35mm |

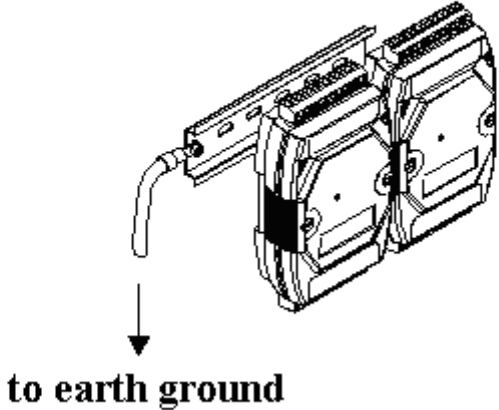

Note: It is recommended that a 16 – 14 AWG wire is used to connect the DIN rail to the earth ground.

1.13.2 Piggyback Mounting

For I-7041/41D, M-7041/41D, I-7042/42D, I-7043/43D, I-7044/44D, I-7050 series, M-7050 series, I-7052/52D, M-7052/52D, I-7060/60D, M-7060/60D, I-7063 series, I-7065 series, I-7066/66D, I-7067/67D and M-7067/67D modules

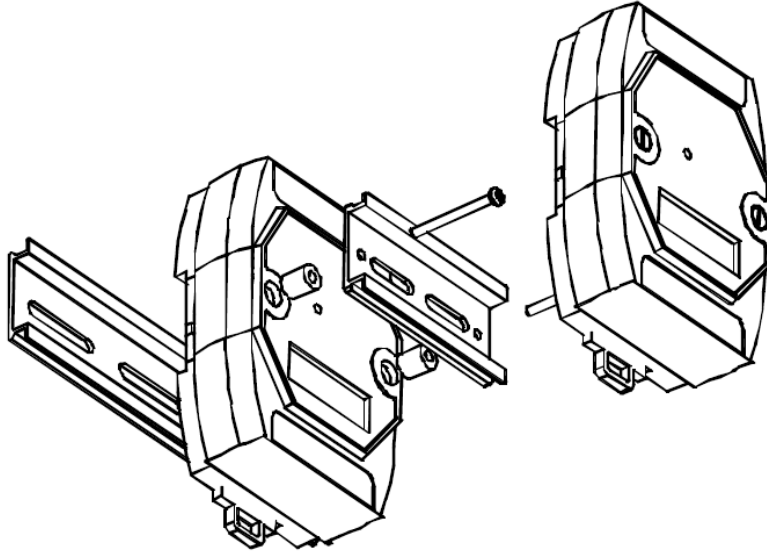

For I-7045/45D, M-7045/45D, I-7051/51D, M-7051/51D, I-7053_FG/53D_FG, M-7053/53D, I-7055/55D, M-7055/55D, I-7058/58D, I-7059/59D, and M-7060P modules

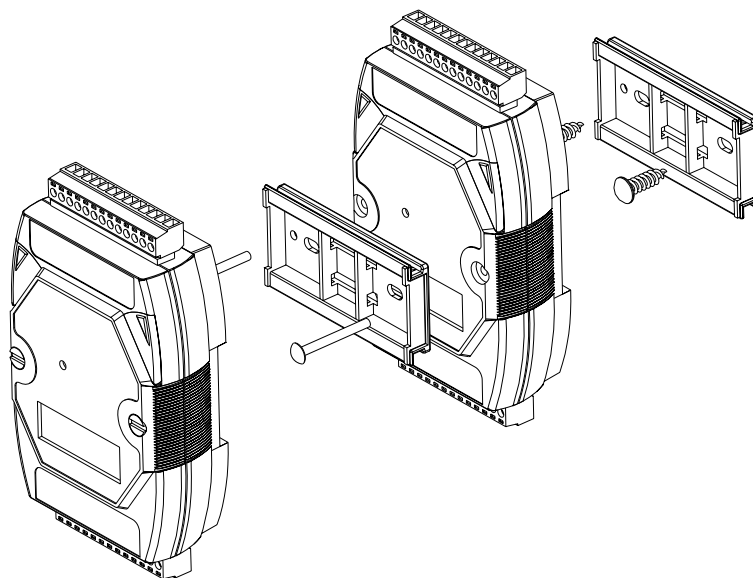

1.13.3 Wall Mounting

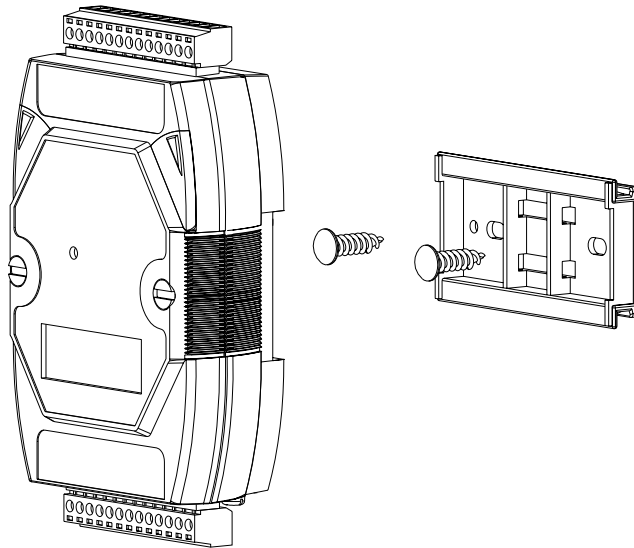

1.14 Technical Support

Should you encounter any problems while using the I-7000 and M-7000 module, and are unable to find the help you need in this manual or on our website, please contact ICP DAS Product Support.

Email: support@icpdas.com

Website: <http://www.icpdas.com/service/support.htm>

When requesting technical support, be prepared to provide the following information about your system:

1. Module name and serial number: The serial number can be found printed on the barcode label attached to the cover of the module.
2. Firmware version: See Sections 2.16 and 3.7.5 for information regarding the command used to identify the firmware version.
3. Host configuration (type and operating system)
4. If the problem is reproducible, please give full details describing the procedure used to reproduce the problem.
5. Any specific error messages displayed. If a dialog box with an error message is displayed, please include the full text of the dialog box, including the text in the title bar.
6. If the problem involves other programs or hardware devices, please describe the details of the problem in full.
7. Any comments and suggestions related to the problem are welcome.

ICP DAS will reply to your request by email within three business days.

2. DCON Protocol

All communication with I-7000 modules consists of commands generated by the host and responses transmitted by the I-7000 modules. Each module has a unique ID number that is used for addressing purposes and is stored in non-volatile memory. The ID is 01 by default and can be changed using a user command. All commands to the modules contain the ID address, meaning that only the addressed module will respond. The only exception to this is commands #** (Section 2.2) and ~** (Section 2.24), which are sent to all modules, but in both of these cases, the modules do not reply to the command.

Command Format:

| | | | | |
|--------------------------|-----------------------|----------------|-----------------|-----------|
| Leading Character | Module Address | Command | [CHKSUM] | CR |
|--------------------------|-----------------------|----------------|-----------------|-----------|

Response Format:

| | | | | |
|--------------------------|-----------------------|-------------|-----------------|-----------|
| Leading Character | Module Address | Data | [CHKSUM] | CR |
|--------------------------|-----------------------|-------------|-----------------|-----------|

CHKSUM A 2-character checksum which is present when the checksum setting is enabled. See Sections 1.10 (Data Format Setting) and 2.1 for details.

CR End of command character, carriage return (0x0D)

Checksum Calculation:

1. Calculate the ASCII code sum of all the characters in the command/response string except for the carriage return character (CR).
2. The checksum is equal to the sum masked by 0FFh.

Example:

Command string: \$012(CR)

1. Sum of the string = "\$"+"0"+"1"+"2" =
 $24h+30h+31h+32h = B7h$
2. Therefore the checksum is B7h, and so
CHKSUM = "B7"
3. The command string with the checksum = \$012B7(CR)

Response string: !01200600(CR)

1. Sum of the string =
"!"+"0"+"1"+"2"+"0"+"0"+"6"+"0"+"0" =
 $21h+30h+31h+32h+30h+30h+36h+30h+30h = 1AAh$
2. Therefore the checksum is AAh, and so
CHKSUM = "AA"
3. The response string with the checksum
= !01200600AA(CR)

Note:

All characters should be in upper case.

| General Command Sets | | | |
|----------------------|-------------|----------------------------------|---------|
| Command | Response | Description | Section |
| %AANNTTCCFF | !AA | Sets the Module Configuration | 2.1 |
| *** | No Response | Synchronized Sampling | 2.2 |
| #AA00(Data) | > | Sets the Digital Output | 2.3 |
| #AA0A(Data) | > | Sets the Digital Output | 2.4 |
| #AA0B(Data) | > | Sets the Digital Output | 2.5 |
| #AA1cDD | > | Sets the Digital Output | 2.6 |
| #AAAcDD | > | Sets the Digital Output | 2.7 |
| #AABcDD | > | Sets the Digital Output. | 2.8 |
| #AAN | !AA(Data) | Reads the Digital Input Counter | 2.9 |
| \$AA2 | !AANNTTCCFF | Reads the Module Configuration | 2.10 |
| \$AA4 | !S(Data) | Reads the Synchronized Data | 2.11 |
| \$AA5 | !AAS | Reads the Reset Status | 2.12 |
| \$AA6 | !(Data) | Reads the Digital I/O Status | 2.13 |
| \$AAC | !AA | Clears the Latched DI Status | 2.14 |
| \$AACN | !AA | Clears the Digital InputCounter | 2.15 |
| \$AAF | !AA(Data) | Reads the firmware Version | 2.16 |
| \$AALS | !(Data) | Reads the Latched DI Status | 2.17 |
| \$AAM | !AA(Data) | Reads the Module Name | 2.18 |
| \$AAP | !AASC | Reads the communication protocol | 2.19 |
| \$AAPN | !AA | Sets the communication protocol | 2.20 |
| @AA | >(Data) | Reads the Digital I/O Status | 2.21 |
| @AA(Data) | > | Sets the Digital Output Channels | 2.22 |
| ~AAO(Name) | !AA | Sets the Module Name | 2.23 |

| Host Watchdog Command Sets | | | |
|----------------------------|-------------|------------------------------|---------|
| Command | Response | Description | Section |
| ~** | No Response | Host OK | 2.24 |
| ~AA0 | !AASS | Reads the Status | 2.25 |
| ~AA1 | !AA | Resets the Status | 2.26 |
| ~AA2 | !AAVV | Reads the Timeout Settings | 2.27 |
| ~AA3EVV | !AA | Sets the Timeout Settings | 2.28 |
| ~AA4V | !AA(Data) | Reads the PowerOn/Safe Value | 2.29 |
| ~AA5V | !AA | Sets the PowerOn/Safe Value | 2.30 |

2.1 %AANNTTCCFF

Description:

Sets the configuration of a module.

Syntax:

%AANNTTCCFF[CHKSUM](CR)

% Delimiter character

AA Address of the module to be configured in hexadecimal format (00 to FF)

NN New address of the module in hexadecimal format (00 to FF)

TT Type code, should be 40 for DIO module.

CC New Baud Rate code, see Section 1.10 for details. The INIT* pin must be connected to ground in order to change Baud Rates. For the module with frame ground, this is achieved by moving the rear slide switch to the INIT position. See Section A.1 for details.

FF Used to set the counter update direction and checksum (Section 1.10). The INIT* pin must be connected to ground in order to change the checksum setting. For the module with frame ground, this is achieved by moving the rear slide switch to the INIT position. See Section A.1 for details.

Response:

Valid Command: **!AA[CHKSUM](CR)**

Invalid Command: **?AA[CHKSUM](CR)**

! Delimiter for a valid command

? Delimiter for an invalid command. If the **Baud Rate** or **checksum** settings are changed without connecting the INIT* pin to ground or switching the rear slide switch to the INIT position, the module will return an invalid command.

AA Address of the module in hexadecimal format (00 to FF)

There will be no response if the command syntax is incorrect, there is a communication error, or there is no module with the specified address.

Examples:

Command: %0102400600 Response: !02

Changes the address of module 01 to 02. The module returns a valid response.

Command: %0101200A00 Response: ?01

Changes the Baud Rate of module 01 to 115200bps. The module returns an invalid command, because it is not in INIT* mode.

Command: %0101200A00 Response: !01

Changes the Baud Rate of module 01 to 115200bps and the module is in INIT* mode. The module returns a valid response.

Related Commands:

Section 2.10 \$AA2

Related Topics:

Section 1.10 Configuration Tables, Section A.1 INIT* pin Operation

Notes:

Changes to the address and counter update direction settings take effect immediately after a valid command is received.

Changes to the Baud Rate and checksum settings take effect on the next power-on reset.

2.2 #**

Description:

When the command is received, it will allow all modules to read data and will store the data for later retrieval.

Syntax:

#**[CHKSUM](CR)

Delimiter character

** Synchronized sampling command

Response:

There is no response with this command. To access the data, another command, \$AA4, must be sent, see Section 2.11 for details.

Examples:

Command: #** No response

Sends the synchronized sampling command.

Command: \$014 Response: !10F0000

Sends a command to read the synchronized data. The status byte of the response is 1, which means that it is the first time the synchronized data has been read after the previous #** command.

Command: \$014 Response: !00F0000

Sends a command to read the synchronized data. The status byte of the response is 0, which means that it is **NOT** the first time the synchronized data has been read after the previous #** command.

Related Commands:

Section 2.11 \$AA4

2.3 #AA00(Data)

Description:

Sets the digital output value of the lower eight channels.

Syntax:

#AA00(Data)[CHKSUM](CR)

| | |
|--------|--|
| # | Delimiter character |
| AA | Address of the module to be set (00 to FF) |
| 00 | Command to set the digital output value of the lower eight channels |
| (Data) | A two-digit hexadecimal value, where bit 0 corresponds to DO0, bit 1 corresponds to DO1, etc. When the bit is 1, it denotes that the digital output channel is on, and 0 denotes that the digital output channel is off. |

Response:

Valid command: **>[CHKSUM](CR)**

Invalid command: **?[CHKSUM](CR)**

Ignored command: **![CHKSUM](CR)**

| | |
|---|---|
| > | Delimiter character for a valid command |
| ? | Delimiter character for an invalid command |
| ! | Delimiter character for an ignored command. A host watchdog timeout has occurred, the digital output channels are set to safe value, and the digital output value that was sent is ignored. |

There will be no response if the command syntax is incorrect, there is a communication error, or there is no module with the specified address.

Examples:

Command: #010033 Response: >
Sets DO0, DO1, DO4 and DO5 to on, and DO2, DO3, DO6, DO7 to off, and the module returns a valid response.

Related Commands:

Section 2.4 #AA0A(data), Section 2.5 #AA0B(data), Section 2.6 #AA1cDD, Section 2.7 #AAAcDD, Section 2.8 #AABcDD, Section 2.13 \$AA6, Section 2.21 @AA

Related Topics:

Section 1.11 DIO Active States

Notes:

1. This command is only applicable to the modules with digital output channels.
2. This command is the same as the #AA0A(Data) command.

2.4 #AA0A(Data)

Description:

Sets the digital output value of the lower eight channels.

Syntax:

#AA0A(Data)[CHKSUM](CR)

- # Delimiter character
- AA Address of the module to be set (00 to FF)
- 0A Command to set the digital output value of the lower eight channels
- (Data) A two-digit hexadecimal value, where bit 0 corresponds to DO0, bit 1 corresponds to DO1, etc. When the bit is 1, it denotes that the digital output channel is on, and 0 denotes that the digital output channel is off.

Response:

Valid command: >[CHKSUM](CR)

Invalid command: ?[CHKSUM](CR)

Ignored command: ![CHKSUM](CR)

- > Delimiter character for a valid command
- ? Delimiter character for an invalid command
- ! Delimiter character for an ignored command. A host watchdog timeout has occurred, the digital output channels are set to safe value, and the digital output value that was sent is ignored.

There will be no response if the command syntax is incorrect, there is a communication error, or there is no module with the specified address.

Examples:

Command: #010A33 Response: >
Sets DO0, DO1, DO4 and DO5 to on, and DO2, DO3, DO6, DO7 to off, and the module returns a valid response.

Related Commands:

Section 2.3 #AA00(data), Section 2.5 #AA0B(data), Section 2.6 #AA1cDD, Section 2.7 #AAAcDD, Section 2.8 #AABcDD, Section 2.13 \$AA6, Section 2.21 @AA

Related Topics:

Section 1.11 DIO Active States

Notes:

1. This command is only applicable to the modules with digital output channels.
2. This command is the same as the #AA00(Data) command.

2.5 #AA0B(Data)

Description:

Sets the digital output value of the upper eight channels.

Syntax:

#AA0B(Data)[CHKSUM](CR)

- # Delimiter character
- AA Address of the module to be set (00 to FF)
- 0B Command to set the digital output value of the upper eight channels
- (Data) A two-digit hexadecimal value, where bit 0 corresponds to DO8, bit 1 corresponds to DO9, etc. When the bit is 1, it denotes that the digital output channel is on, and 0 denotes that the digital output channel is off.

Response:

Valid command: **>[CHKSUM](CR)**

Invalid command: **?[CHKSUM](CR)**

Ignored command: **![CHKSUM](CR)**

- > Delimiter character for a valid command
- ? Delimiter character for an invalid command
- ! Delimiter character for an ignored command. A host watchdog timeout has occurred, the digital output ports are set to safe value, and the digital output value that was sent is ignored.

There will be no response if the command syntax is incorrect, there is a communication error, or there is no module with the specified address.

Examples:

Command: #010B33

Response: >

Sets DO8, DO9, DO12 and DO13 to on, and DO10, DO11, DO14, DO15 to off, and the module returns a valid response.

Related Commands:

Section 2.3 #AA00(data), Section 2.4 #AA0A(data), Section 2.6 #AA1cDD, Section 2.7 #AAAcDD, Section 2.8 #AABcDD, Section 2.13 \$AA6, Section 2.21 @AA

Related Topics:

Section 1.11 DIO Active States

Notes:

This command is only applicable to the modules with the number of digital output channels larger than eight.

2.6 #AA1cDD

Description:

Sets a single digital output channel of the lower eight channels.

Syntax:

#AA1cDD[CHKSUM](CR)

Delimiter character
AA Address of the module to be set (00 to FF)
1 Command to set a single digital output channel of the lower eight channels
c Specifies the digital output channel to be set (0 to 7).
DD 00: set the digital output channel to off.
01: set the digital output channel to on.

Response:

Valid command: >[CHKSUM](CR)

Invalid command: ?[CHKSUM](CR)

Ignored command: ![CHKSUM](CR)

> Delimiter character for a valid command
? Delimiter character for an invalid command
! Delimiter character for an ignored command. A host watchdog timeout has occurred, the digital output ports are set to safe value, and the digital output value that was sent is ignored.

There will be no response if the command syntax is incorrect, there is a communication error, or there is no module with the specified address.

Examples:

Command: #011201

Response: >

Sets DO2 to on, and the module returns a valid response.

Related Commands:

Section 2.3 #AA00(data), Section 2.4 #AA0A(data), Section 2.5 #AA0B(data), Section 2.7 #AAAcDD, Section 2.8 #AABcDD, Section 2.13 \$AA6, Section 2.21 @AA

Related Topics:

Section 1.11 DIO Active States

Notes:

1. This command is only applicable to the modules with digital output channels.
2. This command is the same as the #AAAcDD command.

2.7 #AAAcDD

Description:

Sets a single digital output channel of the lower eight channels.

Syntax:

#AAAcDD[CHKSUM](CR)

- # Delimiter character
- AA Address of the module to be set (00 to FF)
- A Command to set a single digital output channel of the lower eight channels
- c Specifies the digital output channel to be set (0 to 7).
- DD 00: set the digital output channel to off.
01: set the digital output channel to on.

Response:

Valid command: >[CHKSUM](CR)

Invalid command: ?[CHKSUM](CR)

Ignored command: ![CHKSUM](CR)

- > Delimiter character for a valid command
- ? Delimiter character for an invalid command
- ! Delimiter character for an ignored command. A host watchdog timeout has occurred, the digital output ports are set to safe value, and the digital output value that was sent is ignored.

There will be no response if the command syntax is incorrect, there is a communication error, or there is no module with the specified address.

Examples:

Command: #01A201

Response: >

Sets DO2 to on, and the module returns a valid response.

Related Commands:

Section 2.3 #AA00(data), Section 2.4 #AA0A(data), Section 2.5 #AA0B(data), Section 2.6 #AA1cDD, Section 2.8 #AABcDD, Section 2.13 \$AA6, Section 2.21 @AA

Related Topics:

Section 1.11 DIO Active States

Notes:

1. This command is only applicable to the modules with digital output channels.
2. This command is the same as the #AA1cDD command.

2.8 #AABcDD

Description:

Sets a single digital output channel of the upper eight channels.

Syntax:

#AABcDD[CHKSUM](CR)

- # Delimiter character
- AA Address of the module to be set (00 to FF)
- B Command to set a single digital output channel of the upper eight channels
- c Specifies the digital output channel to be set (0 to 7), where 0 stands for channel 8, 1 stands for channel 9, etc.
- DD 00: set the digital output channel to off.
01: set the digital output channel to on.

Response:

Valid command: **>[CHKSUM](CR)**

Invalid command: **?[CHKSUM](CR)**

Ignored command: **![CHKSUM](CR)**

- > Delimiter character for a valid command
- ? Delimiter character for an invalid command
- ! Delimiter character for an ignored command. A host watchdog timeout has occurred, the digital output ports are set to safe value, and the digital output value that was sent is ignored.

There will be no response if the command syntax is incorrect, there is a communication error, or there is no module with the specified address.

Examples:

Command: #01B201 Response: >
 Sets DO10 to on, and the module returns a valid response.

Related Commands:

Section 2.3 #AA00(data), Section 2.4 #AA0A(data), Section 2.5 #AA0B(data), Section 2.6 #AA1cDD, Section 2.7 #AAAcDD, Section 2.13 \$AA6, Section 2.21 @AA

Related Topics:

Section 1.11 DIO Active States

Notes:

This command is only applicable to the modules with the number of digital output channels larger than eight.

2.9 #AAN

Description:

Reads the digital input counter of channel N.

Syntax:

#AAN[CHKSUM](CR)

Delimiter character

AA Address of the module to be read (00 to FF)

N The channel to be read (0 to F).

Response:

Valid Command: **!AA(Data)[CHKSUM](CR)**

Invalid Command: **?AA[CHKSUM](CR)**

! Delimiter character for a valid command

? Delimiter character for an invalid command. An invalid command is returned if the specified channel is incorrect.

(Data) Five decimal digits representing the digital input counter data of the specified channel (00000 to 65535).

AA Address of the responding module (00 to FF)

There will be no response if the command syntax is incorrect, there is a communication error, or there is no module with the specified address.

Examples:

Command: #032

Response: !0300103

Reads data from channel 2 of module 03 and the returned counter value is 103.

Command: #029

Response: ?02

Reads data from channel 9 of module 02. An error is returned because channel 9 is invalid.

Related Commands:

Section 2.15 \$AACN

Notes:

This command is only applicable to the module with digital inputs.

2.10 \$AA2

Description:

Reads the module configuration.

Syntax:

\$AA2[CHKSUM](CR)

| | |
|----|---|
| \$ | Delimiter character |
| AA | Address of the module to be read (00 to FF) |
| 2 | Command to read the module configuration |

Response:

Valid Command: **!AATCCFF[CHKSUM](CR)**

Invalid Command: **?AA[CHKSUM](CR)**

| | |
|----|---|
| ! | Delimiter character for a valid command |
| ? | Delimiter character for an invalid command |
| AA | Address of the responding module (00 to FF) |
| TT | Type code of the module, should be 40 for DIO module. |
| CC | Baud Rate code of the module, see Section 1.10 for details. |
| FF | Checksum and counter update direction settings of the module, see Section 1.10 for details. |

There will be no response if the command syntax is incorrect, there is a communication error, or there is no module with the specified address.

Examples:

Command: \$012

Response: !01400600

Reads the configuration of module 01.

Related Commands:

Section 2.1 %AANNTTCCFF

Related Topics:

Section 1.10 Configuration Tables

2.11 \$AA4

Description:

Reads the synchronized data that was retrieved by the last #** command.

Syntax:

\$AA4[CHKSUM](CR)

\$ Delimiter character

AA Address of the module to be read (00 to FF)

4 Command to read the synchronized data

Response:

Valid Command: **!S(Data)[CHKSUM](CR)**

Invalid Command: **?AA[CHKSUM](CR)**

! Delimiter character for a valid command

? Delimiter character for an invalid command

AA Address of the responding module (00 to FF)

S Status of the synchronized data

1: first read

0: not the first read

(Data) Synchronized data. See Section 1.10 for the data format.

There will be no response if the command syntax is incorrect, there is a communication error, or there is no module with the specified address.

Examples:

Command: \$014

Response: ?01

Reads the synchronized data for module 01. An invalid command is returned because the #** command has not been issued in advance.

Command: #**

No response

Sends the synchronized sampling command.

Command: \$014

Response: !1000F00

Reads the synchronized data for module 01. The module returns the synchronized data and sets the status byte to 1 to indicate that this is the first time the synchronized data has been read.

Command: \$014

Response: !0000F00

Reads the synchronized data for module 01. The module returns the synchronized data and sets the status byte to 0 to indicate that the synchronized data has been read.

Related Commands:

Section 2.2 #**

2.12 \$AA5

Description:

Reads the reset status of a module.

Syntax:

\$AA5[CHKSUM](CR)

\$ Delimiter character

AA Address of the module to be read (00 to FF)

5 Command to read the module reset status

Response:

Valid Command: **!AAS[CHKSUM](CR)**

Invalid Command: **?AA[CHKSUM](CR)**

! Delimiter character for a valid command

? Delimiter character for an invalid command

AA Address of the responding module (00 to FF)

S Reset status of the module

1: This is the first time the command has been sent since the module was powered on.

0: This is not the first time the command has been sent since the module was powered on, which denotes that there has been no module reset since the last \$AA5 command was sent.

There will be no response if the command syntax is incorrect, there is a communication error, or there is no module with the specified address.

Examples:

Command: \$015

Response: !011

Reads the reset status of module 01. The response shows that it is the first time the \$AA5 command has been sent since the module was powered-on.

Command: \$015

Response: !010

Reads the reset status of module 01. The response shows that there has been no module reset since the last \$AA5 command was sent.

Related Topics:

Section A.5 Reset Status

2.13 \$AA6

Description:

Reads the status of the digital input/output channels.

Syntax:

\$AA6[CHKSUM](CR)

\$ Delimiter character

AA Address of the module to be read (00 to FF)

6 Command to read the digital input/output channels

Response:

Valid command: **!(Data)[CHKSUM](CR)**

Invalid command: **?AA[CHKSUM](CR)**

! Delimiter character for a valid command

? Delimiter character for an invalid command

AA Address of the responding module (00 to FF)

(Data) Status of the digital input/output channels, a four-digit hexadecimal value followed by 00. See Section 1.10 for details.

There will be no response if the command syntax is incorrect, there is a communication error, or there is no module with the specified address.

Examples:

Command: \$016

Response: !0F0000

Reads the digital input/output channel status of module 01 (I-7060) and returns 0F0000h, which denotes that RL1, RL2, RL3 and RL4 are on and IN1, IN2, IN3 and IN4 are off.

Related Commands:

Section 2.21 @AA

Related Topics:

Section 1.10 Configuration Tables

2.14 \$AAC

Description:

Clears the status of the latched digital input and output channels.

Syntax:

\$AAC[CHKSUM](CR)

\$ Delimiter character

AA Address of the module to be cleared (00 to FF)

C Command to clear the status of the latched digital input channels

Response:

Valid command: **!AA[CHKSUM](CR)**

Invalid command: **?AA[CHKSUM](CR)**

! Delimiter character for a valid command

? Delimiter character for an invalid command

AA Address of the responding module (00 to FF)

There will be no response if the command syntax is incorrect, there is a communication error, or there is no module with the specified address.

Examples:

Command: \$01L0

Response: !FFFF00

Sends the command to read the status of the low latched digital input channels of module 01 and returns FFFF.

Command: \$01C

Response: !01

Sends the command to clear the status of the latched digital input channels of module 01 and returns a valid response.

Command: \$01L0

Response: !000000

Sends the command to read the status of the low latched digital input channels of module 01 and returns 0000.

Related Commands:

Section 2.17 \$AALS

Notes:

1. This command is only applicable to the modules with digital input channels.
2. Both the status of the low and high latched digital input channels are cleared.

2.15 \$AACN

Description:

Clears the digital input counter of channel N.

Syntax:

\$AACN[CHKSUM](CR)

\$ Delimiter character
AA Address of the module to be cleared (00 to FF)
C Command to clear the digital input counter
N The channel to be cleared (0 to F).

Response:

Valid Command: **!AA[CHKSUM](CR)**
Invalid Command: **?AA[CHKSUM](CR)**
! Delimiter character for a valid command
? Delimiter character for an invalid command. An invalid command is returned if the specified channel is incorrect.
AA Address of the responding module (00 to FF)

There will be no response if the command syntax is incorrect, there is a communication error, or there is no module with the specified address.

Examples:

Command: #032

Response: !0300103

Reads counter data from channel 2 of module 03 and the returned counter value is 103.

Command: \$03C2

Response: !03

Clears the counter value of channel 2 of module 03 and returns a valid response.

Command: #032

Response: !0300000

Reads counter data from channel 2 of module 03 and the returned counter value is 3.

Related Commands:

Section 2.9 #AAN

Notes:

This command is only applicable to the module with digital inputs.

2.16 \$AAF

Description:

Reads the firmware version of a module.

Syntax:

\$AAF[CHKSUM](CR)

\$ Delimiter character

AA Address of the module to be read (00 to FF)

F Command to read the firmware version

Response:

Valid command: **!AA(Data)[CHKSUM](CR)**

Invalid command: **?AA[CHKSUM](CR)**

! Delimiter character for a valid command

? Delimiter character for an invalid command

AA Address of the responding module (00 to FF)

(Data) Firmware version string of the module

There will be no response if the command syntax is incorrect, there is a communication error, or there is no module with the specified address.

Examples:

Command: \$01F Response: !01A2.0

Reads the firmware version of module 01, and shows that it is version A2.0.

Command: \$02F Response: !02B1.1

Reads the firmware version of module 02, and shows that it is version B1.1.

2.17 \$AALS

Description:

Reads the status of the latched digital input and output channels.

Syntax:

\$AALS[CHKSUM](CR)

\$ Delimiter character
AA Address of the module to be read (00 to FF)
L Command to read the latched status
S 0: read the low latched status
 1: read the high latched status

Response:

Valid command: **!(Data)[CHKSUM](CR)**

Invalid command: **?AA[CHKSUM](CR)**

! Delimiter character for a valid command
? Delimiter character for an invalid command
AA Address of the responding module (00 to FF)
(Data) Status of the latched digital input channels, a four-digit hexadecimal value followed by 00. See Section 1.10 for details.

There will be no response if the command syntax is incorrect, there is a communication error, or there is no module with the specified address.

Examples:

Command: \$01L0

Response: !FFFF00

Sends the command to read the status of the low latched digital input channels of module 01 and returns FFFF.

Command: \$01C

Response: !01

Sends the command to clear the status of the latched digital input channels of module 01 and returns a valid response.

Command: \$01L0

Response: !000000

Sends the command to read the status of the low latched digital input channels of module 01 and returns 0000.

Related Commands:

Section 2.14 \$AAC

Related Topics:

Section 1.10 Configuration Tables

Notes:

This command is only applicable to the modules with digital input channels.

2.18 \$AAM

Description:

Reads the name of a module.

Syntax:

\$AAM[CHKSUM](CR)

\$ Delimiter character

AA Address of the module to be read (00 to FF)

M Command to read the module name

Response:

Valid command: **!AA(Data)[CHKSUM](CR)**

Invalid command: **?AA[CHKSUM](CR)**

! Delimiter character for a valid command

? Delimiter character for an invalid command

AA Address of the responding module (00 to FF)

(Name) Name string of the module

There will be no response if the command syntax is incorrect, there is a communication error, or there is no module with the specified address.

Examples:

Command: \$01M

Response: !017042

Reads the module name of module 01 and returns the name "7042".

Related Commands:

Section 2.23 ~AAO(Name)

2.19 \$AAP

Description:

Reads the communication protocol information.

Syntax:

\$AAP[CHKSUM](CR)

\$ Delimiter character

AA Address of the module to be read (00 to FF)

P Command to read the communication protocol

Response:

Valid Response: !AASC[CHKSUM](CR)

Invalid Response: ?AA[CHKSUM](CR)

! Delimiter character for a valid response

? Delimiter character for an invalid response

AA Address of the responding module (00 to FF)

S The protocols supported by the module

0: only DCON protocol is supported

1: both the DCON and Modbus RTU protocols are supported

C The current protocol that is saved in the EEPROM that will be used at the next power-on reset

0: the protocol set in the EEPROM is DCON

1: the protocol set in the EEPROM is Modbus RTU

There will be no response if the command syntax is incorrect, there is a communication error, or there is no module with the specified address.

Examples:

Command: \$01P

Response: !0110

Reads the communication protocol of module 01 and returns a response of 10 meaning that it supports both the DCON and Modbus RTU protocols and the protocol that will be used at the next power-on reset is DCON.

Related Commands:

Section 2.20 \$AAPN

Supported modules

M-7060/M-7060D/M-7067/M-7067D/M-7050/M-7050D/M-7051/M-7051D/M-7052/M-7052D/M-7053/M-7053D/M-7055/M-7055D/M-7041/M-7041D/M-7045/M7045D

2.20 \$AAPN

Description:

Sets the communication protocol.

Syntax:

\$AAPN[CHKSUM](CR)

\$ Delimiter character

AA Address of the module to be read (00 to FF)

P Command to set the communication protocol

N 0: DCON protocol

1: Modbus RTU protocols

Before using this command, the rear slide switch must be in the INIT position. The new protocol is saved in the EEPROM and will be effective after the next power-on reset.

Response:

Valid Response: !AASC[CHKSUM](CR)

Invalid Response: ?AA[CHKSUM](CR)

! Delimiter character for a valid response

? Delimiter character for an invalid response

AA Address of the responding module (00 to FF)

There will be no response if the command syntax is incorrect, there is a communication error, or there is no module with the specified address.

Examples:

Command: \$01P1

Response: ?01

Sets the communication protocol of module 01 to Modbus RTU and returns an invalid response because the module is not in INIT mode.

Command: \$01P1

Response: !01

Sets the communication protocol of module 01 to Modbus RTU and returns a valid response.

Related Commands:

Section 2.19 \$AAP

Supported modules

M-7060/M-7060D/M-7067/M-7067D/M-7050/M-7050D/M-7051/M-7051D/M-7052/M-7052D/M-7053/M-7053D/M-7055/M-7055D/M-7041/M-7041D/M-7045/M7045D

2.21 @AA

Description:

Reads the status of the digital input/output ports.

Syntax:

@AA[CHKSUM](CR)

@ Delimiter character

AA Address of the module to be read (00 to FF)

Response:

Valid command: **>(Data)[CHKSUM](CR)**

Invalid command: **?AA[CHKSUM](CR)**

> Delimiter character for a valid command

? Delimiter character for an invalid command or
invalid type code

AA Address of the responding module (00 to FF)

(Data) Status of the digital input/output ports, a four-digit
hexadecimal value. See Section 1.10 for details.

There will be no response if the command syntax is incorrect, there is a communication error, or there is no module with the specified address.

Examples:

Command: @01

Response: >0F00

Reads the digital input/output port status of module 01 (I-7060) and returns 0F00h, which denotes that RL1, RL2, RL3 and RL4 are on and IN1, IN2, IN3 and IN4 are off.

Related Commands:

Section 2.13 \$AA6

Related Topics:

Section 1.10 Configuration Tables

2.22 @AA(Data)

Description:

Sets the digital output channels.

Syntax:

@AA(Data)[CHKSUM](CR)

@ Delimiter character

AA Address of the module to be set (00 to FF)

(Data) Data to be written to the digital output channels. For the I-7060 and I-7063 series, it is a one-digit hexadecimal value. For the I-7044, I-7050, I-7055, I-7065, I-7066 and I-7067 series, it is a two-digit hexadecimal value. For the I-7042, I-7043 and I-7045 series, it is a four-digit hexadecimal value. Bit 0 of the value corresponds to DO0 and bit 1 of the value corresponds to DO1, etc. When the bit is 1, it denotes that the digital output channel is on, and 0 denotes that the digital output channel is off.

Response:

Valid command: >[CHKSUM](CR)

Invalid command: ?[CHKSUM](CR)

Ignored command: ![CHKSUM](CR)

> Delimiter character for a valid command

? Delimiter character for an invalid command

! Delimiter character for an ignored command. A host watchdog timeout has occurred, the digital output ports are set to safe value, and the digital output value that was sent is ignored.

There will be no response if the command syntax is incorrect, there is a communication error, or there is no module with the specified address.

Examples:

Command: @017

Response: >

For the I-7060 module, sets DO0 to on, DO1 to on, DO2 to on, and DO3 to off, and the module returns a valid response.

Command: @0207

Response: >

For the I-7050 module, sets DO0 to on, DO1 to on, DO2 to on, and other channels to off, and the module returns a valid response.

Command: @030001

Response: >

For the I-7045 module, sets DO0 to on and other channels to off, and the module returns a valid response.

Related Commands:

Section 2.21 @AA

Related Topics:

Section 1.11 DIO Active States

Notes:

This command is only applicable to the modules with digital output channels.

2.23 ~AAO(Name)

Description:

Sets the name of a module.

Syntax:

~AAO(Name)[CHKSUM](CR)

~ Delimiter character

AA Address of the module to be set (00 to FF)

O Command to set the module name

(Name) New name of the module (max. 6 characters).

Response:

Valid command: **!AA[CHKSUM](CR)**

Invalid command: **?AA[CHKSUM](CR)**

! Delimiter character for a valid command

? Delimiter character for an invalid command

AA Address of the responding module (00 to FF)

There will be no response if the command syntax is incorrect, there is a communication error, or there is no module with the specified address.

Examples:

Command: ~01O7050N

Response: !01

Sets the name of module 01 to be “7050N” and returns a valid response.

Command: \$01M

Response: !017050N

Reads the name of module 01 and returns the name “7050N”.

Related Commands:

Section 2.18 \$AAM

2.24 ~**

Description:

Informs all modules that the host is OK.

Syntax:

~**[CHKSUM](CR)

~ Delimiter character

** Host OK command

Response:

No response.

Examples:

Command: ~** No response
Sends a “Host OK” command to all modules.

Related Commands:

Section 2.25 ~AA0, Section 2.26 ~AA1, Section 2.27 ~AA2,
Section 2.28 ~AA3Evv, Section 2.29 ~AA4V, Section 2.30
~AA5V

Related Topics:

Section A.2 Dual Watchdog Operation

2.25 ~AA0

Description:

Reads the host watchdog status of a module.

Syntax:

~AA0[CHKSUM](CR)

- ~ Delimiter character
- AA Address of the module to be read (00 to FF)
- 0 Command to read the module status

Response:

Valid command: **!AASS[CHKSUM](CR)**

Invalid command: **?AA[CHKSUM](CR)**

- ! Delimiter character for a valid command
 - ? Delimiter character for an invalid command
 - AA Address of the responding module (00 to FF)
 - SS Two hexadecimal digits that represent the host watchdog status, where:
 - Bit 7: 0 indicates that the host watchdog is disabled, and 1 indicates that the host watchdog is enabled,
 - Bit 2: 1 indicates that a host watchdog timeout has occurred, and 0 indicates that no host watchdog timeout has occurred.
- The host watchdog status is stored in EEPROM and can only be reset by using the ~AA1 command.

There will be no response if the command syntax is incorrect, there is a communication error, or there is no module with the specified address.

Examples:

Command: ~010

Response: !0100

Reads the host watchdog status of module 01 and returns 00, meaning that the host watchdog is disabled and no host watchdog timeout has occurred.

Command: ~020

Response: !0204

Reads the host watchdog status of module 02 and returns 04, meaning that a host watchdog timeout has occurred.

Related Commands:

Section 2.24 ~**, Section 2.26 ~AA1, Section 2.27 ~AA2, Section 2.28 ~AA3Evv, Section 2.29 ~AA4V, Section 2.30 ~AA5V

Related Topics:

Section A.2 Dual Watchdog Operation

2.26 ~AA1

Description:

Resets the host watchdog timeout status of a module.

Syntax:

~AA1[CHKSUM](CR)

~ Delimiter character

AA Address of the module to be reset (00 to FF)

1 Command to reset the host watchdog timeout status

Response:

Valid command: **!AA[CHKSUM](CR)**

Invalid command: **?AA[CHKSUM](CR)**

! Delimiter character for a valid command

? Delimiter character for an invalid command

AA Address of the responding module (00 to FF)

There will be no response if the command syntax is incorrect, there is a communication error, or there is no module with the specified address.

Examples:

Command: ~010

Response: !0104

Reads the host watchdog status of module 01 and shows that a host watchdog timeout has occurred.

Command: ~011

Response: !01

Resets the host watchdog timeout status of module 01 and returns a valid response.

Command: ~010

Response: !0100

Reads the host watchdog status of module 01 and shows that no host watchdog timeout has occurred.

Related Commands:

Section 2.24 ~**, Section 2.25 ~AA0, Section 2.27 ~AA2, Section 2.28 ~AA3Evv, Section 2.29 ~AA4V, Section 2.30 ~AA5V

Related Topics:

Section A.2 Dual Watchdog Operation

2.27 ~AA2

Description:

Reads the host watchdog timeout value of a module.

Syntax:

~AA2[CHKSUM](CR)

~ Delimiter character

AA Address of the module to be read (00 to FF)

2 Command to read the host watchdog timeout value

Response:

Valid command : **!AAEVV[CHKSUM](CR)**

Invalid command: **?AA[CHKSUM](CR)**

! Delimiter character for a valid command

? Delimiter character for an invalid command

AA Address of the responding module (00 to FF)

E 1: the host watchdog is enabled

0: the host watchdog is disabled

VV Two hexadecimal digits to represent the timeout value in tenths of a second, for example, 01 denotes 0.1 seconds and FF denotes 25.5 seconds.

There will be no response if the command syntax is incorrect, there is a communication error, or there is no module with the specified address.

Examples:

Command: ~012

Response: !011FF

Reads the host watchdog timeout value of module 01 and returns FF, which denotes that the host watchdog is enabled and the host watchdog timeout value is 25.5 seconds.

Related Commands:

Section 2.24 ~**, Section 2.25 ~AA0, Section 2.26 ~AA1, Section 2.28 ~AA3Evv, Section 2.29 ~AA4V, Section 2.30 ~AA5V

Related Topics:

Section A.2 Dual Watchdog Operation

2.28 ~AA3E VV

Description:

Enables/disables the host watchdog and sets the host watchdog timeout value of a module.

Syntax:

~AA3E VV[CHKSUM](CR)

- ~ Delimiter character
- AA Address of the module to be set (00 to FF)
- 3 Command to set the host watchdog
- E 1: enable the host watchdog
0: disable the host watchdog
- VV Two hexadecimal digits to represent the timeout value in tenths of a second, for example, 01 denotes 0.1 seconds and FF denotes 25.5 seconds.

Response:

Valid command: **!AA[CHKSUM](CR)**

Invalid command: **?AA[CHKSUM](CR)**

- ! Delimiter character for a valid command
- ? Delimiter character for an invalid command
- AA Address of the responding module (00 to FF)

There will be no response if the command syntax is incorrect, there is a communication error, or there is no module with the specified address.

Examples:

Command: ~013164

Response: !01

Enables the host watchdog of module 01 and sets the host watchdog timeout value to 10.0 seconds. The module returns a valid response.

Command: ~012

Response: !01164

Reads the host watchdog timeout value of module 01. The module returns 164, which denotes that the host watchdog is enabled and the host watchdog timeout value is 10.0 seconds.

Related Commands:

Section 2.24 ~**, Section 2.25 ~AA0, Section 2.26 ~AA1, Section 2.27 ~AA2, Section 2.29 ~AA4V, Section 2.30 ~AA5V

Related Topics:

Section A.2 Dual Watchdog Operation

Notes:

When a host watchdog timeout occurs, the host watchdog is disabled. The ~AA3EVV command should be sent again to reenable the host watchdog.

2.29 ~AA4V

Description:

Reads the power-on DO value or the safe DO value of a module.

Syntax:

~AA4V[CHKSUM](CR)

- ~ Delimiter character
- AA Address of the module to be read (00 to FF)
- 4 Command to read the power-on DO value or the safe DO value
- V P: Reads the power-on DO value
S: Reads the safe DO value

Response:

Valid command : **!AA(Data)[CHKSUM](CR)**

Invalid command: **?AA[CHKSUM](CR)**

- ! Delimiter character for a valid command
- ? Delimiter character for an invalid command
- AA Address of the responding module (00 to FF)
- (Data) Power-on DO value or safe DO value.
For the I-7042/42D/43/43D/45/45D modules, they are four hexadecimal digits. For other modules, they are two hexadecimal digits followed by 00.

There will be no response if the command syntax is incorrect, there is a communication error, or there is no module with the specified address.

Examples:

Command: ~014S

Response: !010000

Reads the safe DO value of module 01 and returns 0000.

Command: ~014P

Response: !01FF00

Reads the power-on DO value of module 01 and returns FF00.

Related Commands:

Section 2.30 ~AA5V

Related Topics:

Section 1.11 DIO Active States, Section A.2 Dual Watchdog Operation

Notes:

This command is only applicable to the modules with digital output channels.

2.30 ~AA5V

Description:

Sets the current DO value as the power-on DO value or the safe DO value.

Syntax:

~AA5V[CHKSUM](CR)

- ~ Delimiter character
- AA Address of the module to be set (00 to FF)
- 5 Command to set the power-on value or the safe DO value
- V P: Sets the power-on DO value
S: Sets the safe DO value

Response:

Valid command: **!AA[CHKSUM](CR)**

Invalid command: **?AA[CHKSUM](CR)**

- ! Delimiter character for a valid command
- ? Delimiter character for an invalid command
- AA Address of the responding module (00 to FF)

There will be no response if the command syntax is incorrect, there is a communication error, or there is no module with the specified address.

Examples:

Command: @01AA Response: >
Sets the DO value of module 01 to AA and the module returns a valid response.

Command: ~015P Response: !01
Sets the power-on DO value and the module returns a valid response.

Command: @0155 Response: >
Sets the DO value of module 01 to 55 and the module returns a valid response.

Command: ~015S Response: !01
Sets the safe DO value and the module returns a valid response.

Command: ~014P Response: !01AA00
Reads the power-on DO value of module 01. The module returns AA00, which denotes that the power-on DO value is AA.

Command: ~014S Response: !015500
Reads the safe DO value of module 01. The module returns 5500, which denotes that the safe DO value is 55.

Related Commands:

Section 2.29 ~AA4V

Related Topics:

Section A.2 Dual Watchdog Operation

Notes:

This command is only applicable to the modules with the digital output channels.

2.31 ~AAD

Description:

Reads the miscellaneous settings of a module.

Syntax:

~AAD[CHKSUM](CR)

~ Delimiter character

AA Address of the module to be read (00 to FF)

D Command to read the miscellaneous settings

Response:

Valid Command: !AAT[CHKSUM](CR)

Invalid Command: ?AA[CHKSUM](CR)

! Delimiter character for a valid command

? Delimiter character for an invalid command

AA Address of the responding module (00 to FF)

VV Two hexadecimal digits that represent the miscellaneous settings as follows:

| | | | | | | | |
|----------|---|---|---|---|---|----|----|
| 7 | 6 | 5 | 4 | 3 | 2 | 1 | 0 |
| Reserved | | | | | | 0A | IA |

| Key | Description |
|-----|---|
| 0A | DO active state 0: output value 1 for relay active output value 0 for relay inactive 1: output value 0 for relay active output value 1 for relay inactive |
| IA | DI active state 0: input value 1 for non-signal or the low voltage; input value 0 for high voltage 1: input value 0 for non-signal or the low voltage; input value 1 for high voltage |

There will be no response if the command syntax is incorrect, there is a communication error, or there is no module with the specified address.

Examples:

| | |
|---------------|-----------------|
| Command: ~01D | Response: !0101 |
|---------------|-----------------|

Reads the miscellaneous settings of module 01 and returns 01.

Related Commands:

Section 2.32 ~AADVV

Notes:

This command is only applicable to the M-7000 DIO modules.

2.32 ~AADVV

Description:

Sets the miscellaneous settings of a module.

Syntax:

~AADVV[CHKSUM](CR)

- ~ Delimiter character
- AA Address of the module to be set (00 to FF)
- D Command to set the miscellaneous settings
- VV Two hexadecimal digits that represent the miscellaneous settings as follows:

| | | | | | | | |
|----------|---|---|---|---|---|----|----|
| 7 | 6 | 5 | 4 | 3 | 2 | 1 | 0 |
| Reserved | | | | | | OA | IA |

| Key | Description |
|-----|---|
| OA | DO active state 0: output value 1 for relay active output value 0 for relay inactive 1: output value 0 for relay active output value 1 for relay inactive |
| IA | DI active state 0: input value 1 for non-signal or the low voltage; input value 0 for high voltage 1: input value 0 for non-signal or the low voltage; input value 1 for high voltage |

Response:

Valid Command: **!AA[CHKSUM](CR)**

Invalid Command: **?AA[CHKSUM](CR)**

! Delimiter character for a valid command

? Delimiter character for an invalid command

AA Address of the responding module (00 to FF)

There will be no response if the command syntax is incorrect, there is a communication error, or there is no module with the specified address.

Examples:

Command: ~01D01

Response: !01

Sets the miscellaneous settings of module 01 to 01,
and returns a valid response.

Related Commands:

Section 2.31 ~AAD

Notes:

This command is only applicable to the M-7000 DIO modules.

3. Modbus RTU Protocol

The Modbus protocol is developed by Modicon Inc., originally developed for Modicon controllers. Detailed information can be found at <http://www.modicon.com/techpubs/toc7.html>. You can also visit <http://www.modbus.org> to find more valuable information.

M-7000 series modules support the Modbus RTU protocol. The communication Baud Rates range from 1200bps to 115200bps. The parity, data bits and stop bits are fixed as no parity, 8 data bits and 1 stop bit. The following Modbus functions are supported.

| Function code | Description | Section |
|----------------------|-------------------------------|----------------|
| 01 (0x01) | Read coils | 3.1 |
| 02 (0x02) | Read discrete inputs | 3.2 |
| 03 (0x03) | Read multiple registers | 3.3 |
| 04 (0x04) | Read multiple input registers | 3.4 |
| 05 (0x05) | Write single coil | 3.5 |
| 15 (0x0F) | Write multiple coils | 3.6 |
| 70 (0x46) | Read/write module settings | 3.7 |

If the function specified in the message is not supported, then the module responds as follows.

Error Response

| | | | |
|----|----------------|--------|----------------------|
| 00 | Address | 1 Byte | 1 to 247 |
| 01 | Function code | 1 Byte | Function code + 0x80 |
| 02 | Exception code | 1 Byte | 01 |

If a CRC mismatch occurs, the module will not respond.

3.1 01 (0x01) Read Coils

This function code is used to read the current digital output readback value of the M-7000 DIO module.

Request

| | | | |
|---------|--------------------------|---------|--|
| 00 | Address | 1 Byte | 1 ~ 247 |
| 01 | Function code | 1 Byte | 0x01 |
| 02 ~ 03 | Starting channel numbers | 2 Bytes | 0x0000~0x001F for DO readback value 0x0020~0x003F for DI value 0x0040~0x005F for DIO Latch high value 0x0060~0x007F for DIO Latch low value |
| 04 ~ 05 | Output channel number | 2 Bytes | 0x0001 ~ 0x001F |

Response

| | | | |
|----|-------------------------------|--------|---|
| 00 | Address | 1 Byte | 1 ~ 247 |
| 01 | Function code | 1 Byte | 0x01 |
| 02 | Byte count | 1 Byte | 1 |
| 03 | Output channel readback value | 1 Byte | Refer to the Supported Modules section for the details of the value |

Error Response

| | | | |
|----|----------------|--------|--|
| 00 | Address | 1 Byte | 1 ~ 247 |
| 01 | Function code | 1 Byte | 0x81 |
| 02 | Exception code | 1 Byte | Refer to the Modbus standard for more details. |

Supported Modules

M-7060/M-7060D:

| | |
|------------------------|---------------------------------------|
| Valid starting channel | 0x0000~0x 0003 for DO readback value |
| | 0x0020~0x0023 for DI value |
| | 0x0040~0x0043 for DI Latch high value |
| | 0x0044~0x0047 for DO Latch high value |
| | 0x0060~0x0063 for DI Latch low value |
| | 0x0064~0x0067 for DO Latch low value |

M-7067/M-7067D:

| | |
|------------------------|---------------------------------------|
| Valid starting channel | 0x0000~0x 0006 for DO readback value |
| | 0x0040~0x0046 for DO Latch high value |
| | 0x0060~0x0066 for DO Latch low value |

M-7055/M-7055D:

| | |
|------------------------|---------------------------------------|
| Valid starting channel | 0x0000~0x 0007 for DO readback value |
| | 0x0020~0x0027 for DI value |
| | 0x0040~0x0047 for DI Latch high value |
| | 0x0048~0x004F for DO Latch high value |
| | 0x0060~0x0067 for DI Latch low value |
| | 0x0068~0x006F for DO Latch low value |

M-7052/M-7052D:

| | |
|------------------------|---------------------------------------|
| Valid starting channel | 0x0020~0x0027 for DI value |
| | 0x0040~0x0047 for DI Latch high value |
| | 0x0060~0x0067 for DI Latch low value |

M-7053/M-7053D:

| | |
|------------------------|---------------------------------------|
| Valid starting channel | 0x0020~0x002F for DI value |
| | 0x0040~0x004F for DI Latch high value |
| | 0x0060~0x006F for DI Latch low value |

M-7041/M-7041D:

| | |
|------------------------|---------------------------------------|
| Valid starting channel | 0x0020~0x002D for DI value |
| | 0x0040~0x004D for DI Latch high value |
| | 0x0060~0x006D for DI Latch low value |

M-7045/M-7045D:

| | |
|------------------------|---------------------------------------|
| Valid starting channel | 0x0000~0x 000F for DO readback value |
| | 0x0040~0x004F for DO Latch high value |
| | 0x0060~0x006F for DO Latch low value |

M-7051/M-7051D:

| | |
|------------------------|---------------------------------------|
| Valid starting channel | 0x0020~0x002F for DI value |
| | 0x0040~0x004F for DI Latch high value |
| | 0x0060~0x006F for DI Latch low value |

M-7050/M-7050D:

| | |
|------------------------|---------------------------------------|
| Valid starting channel | 0x0000~0x 0007 for DO readback value |
| | 0x0020~0x0026 for DI value |
| | 0x0040~0x0046 for DI Latch high value |
| | 0x0048~0x004F for DO Latch high value |
| | 0x0060~0x0066 for DI Latch low value |
| | 0x0068~0x006F for DO Latch low value |

3.2 02 (0x02) Read Discrete Inputs

This function code is used to read the current digital input value of the M-7000 DIO module.

Request

| | | | |
|---------|----------------------|---------|-----------------|
| 00 | Address | 1 Byte | 1 ~ 247 |
| 01 | Function code | 1 Byte | 0x02 |
| 02 ~ 03 | Starting channel | 2 Bytes | 0x0000 ~ 0x001F |
| 04 ~ 05 | Input channel number | 2 Bytes | 0x0001 ~ 0x0020 |

Response

| | | | |
|----|--------------------|--------|--|
| 00 | Address | 1 Byte | 1 ~ 247 |
| 01 | Function code | 1 Byte | 0x02 |
| 02 | Byte count | 1 Byte | 1 |
| 03 | Input channel data | 1 Byte | Refer to the Supported Modules section for details of the value. |

Error Response

| | | | |
|----|----------------|--------|--|
| 00 | Address | 1 Byte | 1 ~ 247 |
| 01 | Function code | 1 Byte | 0x82 |
| 02 | Exception code | 1 Byte | Refer to the Modbus standard for more details. |

Supported Modules

M-7060/M-7060D:

| | |
|------------------------|-----------------------------|
| Valid starting channel | 0x0000~0x 0003 for DI value |
|------------------------|-----------------------------|

M-7055/M-7055D:

| | |
|------------------------|-----------------------------|
| Valid starting channel | 0x0000~0x 0007 for DI value |
|------------------------|-----------------------------|

M-7052/M-7052D:

| | |
|------------------------|----------------------------|
| Valid starting channel | 0x0000~0x0007 for DI value |
|------------------------|----------------------------|

M-7053/M-7053D:

| | |
|------------------------|----------------------------|
| Valid starting channel | 0x0000~0x000F for DI value |
|------------------------|----------------------------|

M-7041/M-7041D:

| | |
|------------------------|----------------------------|
| Valid starting channel | 0x0000~0x000D for DI value |
|------------------------|----------------------------|

M-7051/M-7051D:

| | |
|------------------------|----------------------------|
| Valid starting channel | 0x0000~0x000F for DI value |
|------------------------|----------------------------|

M-7050/M-7050D:

| | |
|------------------------|-----------------------------|
| Valid starting channel | 0x0000~0x 0006 for DI value |
|------------------------|-----------------------------|

3.3 03 (0x03) Read Multiple Registers

This function code is used to read the current digital input counter value of the M-7000 DIO module.

Request

| | | | |
|---------|--------------------------|---------|-----------------|
| 00 | Address | 1 Byte | 1 ~ 247 |
| 01 | Function code | 1 Byte | 0x03 |
| 02 ~ 03 | Starting channel numbers | 2 Bytes | 0x0000 ~ 0x001F |
| 04 ~ 05 | Input channel number | 2 Bytes | 0x0001 ~ 0x0020 |

Response

| | | | |
|-----|-----------------------------|--------------|---|
| 00 | Address | 1 Byte | 1 ~ 247 |
| 01 | Function code | 1 Byte | 0x03 |
| 02 | Byte count | 1 Byte | 1 |
| 03~ | Input channel counter value | *N x 2 Bytes | Each channel can record a maximum counter value up to 65535 (0xFFFF). |

*N = Number of input channels

Error Response

| | | | |
|----|----------------|--------|--|
| 00 | Address | 1 Byte | 1 ~ 247 |
| 01 | Function code | 1 Byte | 0x83 |
| 02 | Exception code | 1 Byte | Refer to the Modbus standard for more details. |

Supported Modules

M-7060/M-7060D:

| | |
|------------------------|-------------------------------------|
| Valid starting channel | 0x0000~0x 0003 for DI counter value |
|------------------------|-------------------------------------|

M-7055/M-7055D:

| | |
|------------------------|-------------------------------------|
| Valid starting channel | 0x0000~0x 0007 for DI counter value |
|------------------------|-------------------------------------|

M-7052/M-7052D:

| | |
|------------------------|-------------------------------------|
| Valid starting channel | 0x0000~0x 0007 for DI counter value |
|------------------------|-------------------------------------|

M-7053/M-7053D:

| | |
|------------------------|------------------------------------|
| Valid starting channel | 0x0000~0x000F for DI counter value |
|------------------------|------------------------------------|

M-7041/M-7041D:

| | |
|------------------------|------------------------------------|
| Valid starting channel | 0x0000~0x000D for DI counter value |
|------------------------|------------------------------------|

M-7051/M-7051D:

| | |
|------------------------|------------------------------------|
| Valid starting channel | 0x0000~0x000F for DI counter value |
|------------------------|------------------------------------|

M-7050/M-7050D:

| | |
|------------------------|-------------------------------------|
| Valid starting channel | 0x0000~0x 0006 for DI counter value |
|------------------------|-------------------------------------|

3.4 04 (0x04) Read Multiple Input Registers

This function code is used to read the current digital input counter value of the M-7000 DIO module.

Request

| | | | |
|---------|--------------------------|---------|-----------------|
| 00 | Address | 1 Byte | 1 ~ 247 |
| 01 | Function code | 1 Byte | 0x04 |
| 02 ~ 03 | Starting channel numbers | 2 Bytes | 0x0000 ~ 0x001F |
| 04 ~ 05 | Input channel number | 2 Bytes | 0x0001 ~ 0x0020 |

Response

| | | | |
|-----|-----------------------------|--------------|---|
| 00 | Address | 1 Byte | 1 ~ 247 |
| 01 | Function code | 1 Byte | 0x04 |
| 02 | Byte count | 1 Byte | 1 |
| 03~ | Input channel counter value | *N x 2 Bytes | Each channel can record the maximum counter value up to 65535 (0xFFFF). |

*N = Number of input channels

Error Response

| | | | |
|----|----------------|--------|--|
| 00 | Address | 1 Byte | 1 ~ 247 |
| 01 | Function code | 1 Byte | 0x84 |
| 02 | Exception code | 1 Byte | Refer to the Modbus standard for more details. |

Supported Modules

M-7060/M-7060D:

| | |
|------------------------|-------------------------------------|
| Valid starting channel | 0x0000~0x 0003 for DI counter value |
|------------------------|-------------------------------------|

M-7055/M-7055D:

| | |
|------------------------|-------------------------------------|
| Valid starting channel | 0x0000~0x 0007 for DI counter value |
|------------------------|-------------------------------------|

M-7052/M-7052D:

| | |
|------------------------|-------------------------------------|
| Valid starting channel | 0x0000~0x 0007 for DI counter value |
|------------------------|-------------------------------------|

M-7053/M-7053D:

| | |
|------------------------|------------------------------------|
| Valid starting channel | 0x0000~0x000F for DI counter value |
|------------------------|------------------------------------|

M-7041/M-7041D:

| | |
|------------------------|------------------------------------|
| Valid starting channel | 0x0000~0x000D for DI counter value |
|------------------------|------------------------------------|

M-7051/M-7051D:

| | |
|------------------------|------------------------------------|
| Valid starting channel | 0x0000~0x000F for DI counter value |
|------------------------|------------------------------------|

M-7050/M-7050D:

| | |
|------------------------|-------------------------------------|
| Valid starting channel | 0x0000~0x 0006 for DI counter value |
|------------------------|-------------------------------------|

3.5 05 (0x05) Write Single Coils

This function code is used to write the digital output value of the M-7000 DIO module.

Request

| | | | |
|---------|------------------------|---------|---|
| 00 | Address | 1 Byte | 1 ~ 247 |
| 01 | Function code | 1 Byte | 0x05 |
| 02 ~ 03 | Output channel numbers | 2 Bytes | 0x0000 ~ 0x001F 0x0100 to clear the latch value 0x0200~0x0220 to clear the DI counter value |
| 04 ~ 05 | Output value | 2 Bytes | A value of 0xFF00 sets the output to ON. A value of 0x0000 sets it to OFF. All other values are illegal and will not affect the coil. |

Response

| | | | |
|---------|------------------------|---------|--|
| 00 | Address | 1 Byte | 1 ~ 247 |
| 01 | Function code | 1 Byte | 0x05 |
| 02 ~ 03 | Output channel numbers | 2 Bytes | The value is the same as byte 02 and 03 of the Request |
| 04 ~ 05 | Output value | 2 Bytes | The value is the same as byte 04 and 05 of the Request |

Error Response

| | | | |
|----|----------------|--------|--|
| 00 | Address | 1 Byte | 1 ~ 247 |
| 01 | Function code | 1 Byte | 0x85 |
| 02 | Exception code | 1 Byte | Refer to the Modbus standard for more details. |

Supported Modules

M-7060/M-7060D:

| | |
|----------------------|--|
| Valid output channel | 0x0000~0x0003 for DO output |
| | 0x0100 to clear the DIO latch value. If setting this channel to ON, the latch value will become 0. |
| | 0x0200~0x0203 to clear the DI counter value |

M-7067/M-7067D:

| | |
|------------------------|---|
| Valid starting channel | 0x0000~0x 0006 for DO output |
| | 0x0100 to clear the DO latch value. If setting this channel to ON, the latch value will become 0. |

M-7055/M-7055D:

| | |
|----------------------|--|
| Valid output channel | 0x0000~0x 0007 for DO output |
| | 0x0100 to clear the DIO latch value. If setting this channel to ON, the latch value will become 0. |
| | 0x0200~0x0207 to clear the DI counter value |

M-7052/M-7052D:

| | |
|----------------------|---|
| Valid output channel | 0x0100 to clear the DI latch value. If setting this channel to ON, the latch value will become 0. |
| | 0x0200~0x0207 to clear the DI counter value |

M-7053/M-7053D:

| | |
|----------------------|---|
| Valid output channel | 0x0100 to clear the DI latch value. If setting this channel to ON, the latch value will become 0. |
| | 0x0200~0x020F to clear the DI counter value |

M-7041/M-7041D:

| | |
|----------------------|---|
| Valid output channel | 0x0100 to clear the DI latch value. If setting this channel to ON, the latch value will become 0. |
| | 0x0200~0x020D to clear the DI counter value |

M-7045/M-7045D:

| | |
|------------------------|---|
| Valid starting channel | 0x0000~0x 000F for DO output |
| | 0x0100 to clear the DO latch value. If setting this channel to ON, the latch value will become 0. |

M-7051/M-7051D:

| | |
|----------------------|--|
| Valid output channel | 0x0100 to clear the DI latch value. If setting this channel to ON, the latch value will become 0. 0x0200~0x020F to clear the DI counter value |
|----------------------|--|

M-7050/M-7050D:

| | |
|----------------------|--|
| Valid output channel | 0x0000~0x 0007 for DO output |
| | 0x0100 to clear the DIO latch value. If setting this channel to ON, the latch value will become 0. |
| | 0x0200~0x0206 to clear the DI counter value |

3.6 15 (0x0F) Write Multiple Coils

This function code is used to write the digital output value of the M-7000 DIO module.

Request

| | | | |
|---------|--------------------------|---------|--|
| 00 | Address | 1 Byte | 1 ~ 247 |
| 01 | Function code | 1 Byte | 0x0F |
| 02 ~ 03 | Starting channel numbers | 2 Bytes | 0x0000 ~ 0x001F for DO output 0x0200~0x0220 to clear the DI count value |
| 04 ~ 05 | Output channel number | 2 Bytes | 0x0001 ~ 0x0020 |
| 06 | Byte count | 1 Byte | 1 |
| 07 | Output value | 1 Byte | A bit corresponds to a channel. When the bit is 1 it denotes that the value of the channel that was set is ON. If the bit is 0 it denotes that the value of the channel that was set is OFF. |

Response

| | | | |
|---------|--------------------------|---------|--|
| 00 | Address | 1 Byte | 1 ~ 247 |
| 01 | Function code | 1 Byte | 0x0F |
| 02 ~ 03 | Starting channel numbers | 2 Bytes | The value is the same as byte 02 and 03 of the Request |
| 04 ~ 05 | Input channel number | 2 Bytes | The value is the same as byte 04 and 05 of the Request |

Error Response

| | | | |
|----|----------------|--------|--|
| 00 | Address | 1 Byte | 1 ~ 247 |
| 01 | Function code | 1 Byte | 0x8F |
| 02 | Exception code | 1 Byte | Refer to the Modbus standard for more details. |

Supported Modules

M-7060/M-7060D:

| | |
|------------------------|---|
| Valid starting channel | 0x0000~0x0003 for DO output |
| | 0x0200~0x0203 to clear the DI counter value |

M-7067/M-7067D:

| | |
|------------------------|-----------------------------|
| Valid starting channel | 0x0000~0x0006 for DO output |
|------------------------|-----------------------------|

M-7055/M-7055D:

| | |
|------------------------|---|
| Valid starting channel | 0x0000~0x0007 for DO output |
| | 0x0200~0x0207 to clear the DI counter value |

M-7052/M-7052D:

| | |
|------------------------|---|
| Valid starting channel | 0x0200~0x0207 to clear the DI counter value |
|------------------------|---|

M-7053/M-7053D:

| | |
|------------------------|---|
| Valid starting channel | 0x0200~0x020F to clear the DI counter value |
|------------------------|---|

M-7041/M-7041D:

| | |
|------------------------|---|
| Valid starting channel | 0x0200~0x020D to clear the DI counter value |
|------------------------|---|

M-7045/M-7045D:

| | |
|------------------------|-----------------------------|
| Valid starting channel | 0x0000~0x000F for DO output |
|------------------------|-----------------------------|

M-7051/M-7051D:

| | |
|------------------------|---|
| Valid starting channel | 0x0200~0x020F to clear the DI counter value |
|------------------------|---|

M-7050/M-7050D:

| | |
|------------------------|---|
| Valid starting channel | 0x0000~0x0007 for DO output |
| | 0x0200~0x0206 to clear the DI counter value |

3.7 70 (0x46) Read/Write Module Settings

This function code is used to read the settings of the module or change the settings of the module. The following sub-function codes are supported.

| Sub-function Code | Description | Section |
|-------------------|--------------------------------------|---------|
| 00 (0x00) | Read the module name | 3.7.1 |
| 04 (0x04) | Set the module address | 3.7.2 |
| 05 (0x05) | Read the communication settings | 3.7.3 |
| 06 (0x06) | Set the communication settings | 3.7.4 |
| 32 (0x20) | Read the firmware version | 3.7.5 |
| 33 (0x21) | Set the DI count edge | 3.7.6 |
| 34 (0x22) | Read the DI count edge setting value | 3.7.7 |
| 39 (0x27) | Set the DO power-on value | 3.7.8 |
| 40 (0x28) | Read the DO power-on value | 3.7.9 |
| 41 (0x29) | Set the DI/O active states | 3.7.10 |
| 42 (0x2A) | Read the DI/O active states | 3.7.11 |

If the module does not support the sub-function code specified in the message, then it responds as follows:

Error Response

| | | | |
|----|----------------|--------|--|
| 00 | Address | 1 Byte | 1 ~ 247 |
| 01 | Function code | 1 Byte | 0xC6 |
| 02 | Exception code | 1 Byte | Refer to the Modbus standard for more details. |

3.7.1 Sub-function 00 (0x00) Read module name

This sub-function code is used to read the name of a module.

Request

| | | | |
|----|-------------------|--------|---------|
| 00 | Address | 1 Byte | 1 ~ 247 |
| 01 | Function code | 1 Byte | 0x46 |
| 02 | Sub-function code | 1 Byte | 0x00 |

Response

| | | | |
|---------|-------------------|---------|--|
| 00 | Address | 1 Byte | 1 ~ 247 |
| 01 | Function code | 1 Byte | 0x46 |
| 02 | Sub-function code | 1 Byte | 0x00 |
| 03 ~ 06 | Module name | 4 Bytes | 0x00 0x70 0x60 0x00 for M-7060/M-7060D modules 0x00 0x70 0x67 0x00 for M-7067/M-7060D modules |

Error Response

| | | | |
|----|----------------|--------|--|
| 00 | Address | 1 Byte | 1 ~ 247 |
| 01 | Function code | 1 Byte | 0xC6 |
| 02 | Exception code | 1 Byte | Refer to the Modbus standard for more details. |

Supported Modules

M-7060/M-7060D/M-7067/M-7067D/M-7050/M-7050D/M-7051/M-7051D/M-7052/M-7052D/M-7053/M-7053D/M-7055/M-7055D/M-7041/M-7041D/M-7045/M7045D

3.7.2 Sub-function 04 (0x04) Set module address

This sub-function code is used to set the address of a module.

Request

| | | | |
|--------|-------------------|---------|----------------|
| 00 | Address | 1 Byte | 1 ~ 247 |
| 01 | Function code | 1 Byte | 0x46 |
| 02 | Sub-function code | 1 Byte | 0x04 |
| 03 | Address | 1 Byte | 1 ~ 247 |
| 04~ 06 | Reserved | 3 Bytes | 0x00 0x00 0x00 |

Response

| | | | |
|--------|--------------------|---------|------------------------|
| 00 | Address | 1 Byte | 1 ~ 247 |
| 01 | Function code | 1 Byte | 0x46 |
| 02 | Sub-function code | 1 Byte | 0x04 |
| 03 | Set address result | 1 Byte | 0: OK Others: error |
| 04~ 06 | Reserved | 3 Bytes | 0x00 0x00 0x00 |

Error Response

| | | | |
|----|----------------|--------|--|
| 00 | Address | 1 Byte | 1 ~ 247 |
| 01 | Function code | 1 Byte | 0xC6 |
| 02 | Exception code | 1 Byte | Refer to the Modbus standard for more details. |

Supported Modules

M-7060/M-7060D/M-7067/M-7067D/M-7050/M-7050D/M-7051/M-7051D/M-7052/M-7052D/M-7053/M-7053D/M-7055/M-7055D/M-7041/M-7041D/M-7045/M7045D

3.7.3 Sub-function 05 (0x05) Read communication settings

This sub-function code is used to read the communication protocol settings of a module.

Request

| | | | |
|----|-------------------|--------|---------|
| 00 | Address | 1 Byte | 1 ~ 247 |
| 01 | Function code | 1 Byte | 0x46 |
| 02 | Sub-function code | 1 Byte | 0x05 |
| 03 | Reserved | 1 Byte | 0x00 |

Response

| | | | |
|--------|-------------------|---------|---|
| 00 | Address | 1 Byte | 1 ~ 247 |
| 01 | Function code | 1 Byte | 0x46 |
| 02 | Sub-function code | 1 Byte | 0x05 |
| 03 | Reserved | 1 Byte | 0x00 |
| 04 | Baud Rate | 1 Byte | Baud rate code, see Section 1.10 for details. |
| 05~ 07 | Reserved | 3 Bytes | 0x00 0x00 0x00 |
| 08 | Mode | 1 Byte | 0: DCON protocol 1: Modbus RTU protocol |
| 09~10 | Reserved | 2 Bytes | 0x00 0x00 |

Note: This information is the data saved in the EEPROM and will be used for the next power-on reset. It is not the currently used settings.

Error Response

| | | | |
|----|----------------|--------|--|
| 00 | Address | 1 Byte | 1 ~ 247 |
| 01 | Function code | 1 Byte | 0xC6 |
| 02 | Exception code | 1 Byte | Refer to the Modbus standard for more details. |

Supported Modules

M-7060/M-7060D/M-7067/M-7067D/M-7050/M-7050D/M-7051/M-7051D/M-7052/M-7052D/M-7053/M-7053D/M-7055/M-7055D/M-7041/M-7041D/M-7045/M7045D

3.7.4 Sub-function 06 (0x06) Set communication settings

This sub-function code is used to set the communication protocol of a module.

Request

| | | | |
|--------|-------------------|---------|---|
| 00 | Address | 1 Byte | 1 ~ 247 |
| 01 | Function code | 1 Byte | 0x46 |
| 02 | Sub-function code | 1 Byte | 0x06 |
| 03 | Reserved | 1 Byte | 0x00 |
| 04 | Baud Rate | 1 Byte | Baud rate code, see Section 1.10 for details. |
| 05~ 07 | Reserved | 3 Bytes | 0x00 0x00 0x00 |
| 08 | Mode | 1 Byte | 0: DCON protocol 1: Modbus RTU protocol |
| 09~10 | Reserved | 2 Bytes | 0x00 0x00 |

Response

| | | | |
|--------|-------------------|---------|-------------------------|
| 00 | Address | 1 Byte | 1 ~ 247 |
| 01 | Function code | 1 Byte | 0x46 |
| 02 | Sub-function code | 1 Byte | 0x06 |
| 03 | Reserved | 1 Byte | 0x00 |
| 04 | Baud Rate | 1 Byte | 0: OK, others: error |
| 05~ 07 | Reserved | 3 Bytes | 0x00 0x00 0x00 |
| 08 | Mode | 1 Byte | 0: OK, others: error |
| 09~10 | Reserved | 2 Bytes | 0x00 0x00 |

Note: The new baud rate and protocol will be effective after the next power-on reset.

Error Response

| | | | |
|----|----------------|--------|--|
| 00 | Address | 1 Byte | 1 ~ 247 |
| 01 | Function code | 1 Byte | 0xC6 |
| 02 | Exception code | 1 Byte | Refer to the Modbus standard for more details. |

Supported Module

M-7060/M-7060D/M-7067/M-7067D/M-7050/M-7050D/M-7051/M-7051D/M-7052/M-7052D/M-7053/M-7053D/M-7055/M-7055D/M-7041/M-7041D/M-7045/M7045D

3.7.5 Sub-function 32 (0x20) Read firmware version

This sub-function code is used to read the firmware version information of a module.

Request

| | | | |
|----|-------------------|--------|---------|
| 00 | Address | 1 Byte | 1 ~ 247 |
| 01 | Function code | 1 Byte | 0x46 |
| 02 | Sub-function code | 1 Byte | 0x20 |

Response

| | | | |
|----|-------------------|--------|-----------|
| 00 | Address | 1 Byte | 1 ~ 247 |
| 01 | Function code | 1 Byte | 0x46 |
| 02 | Sub-function code | 1 Byte | 0x20 |
| 03 | Major version | 1 Byte | 0x00~0xFF |
| 04 | Minor version | 1 Byte | 0x00~0xFF |
| 05 | Build version | 1 Byte | 0x00~0xFF |

Error Response

| | | | |
|----|----------------|--------|--|
| 00 | Address | 1 Byte | 1 ~ 247 |
| 01 | Function code | 1 Byte | 0xC6 |
| 02 | Exception code | 1 Byte | Refer to the Modbus standard for more details. |

Supported Modules

M-7060/M-7060D/M-7067/M-7067D/M-7050/M-7050D/M-7051/M-7051D/M-7052/M-7052D/M-7053/M-7053D/M-7055/M-7055D/M-7041/M-7041D/M-7045/M7045D

3.7.6 Sub-function 33 (0x21) Set digital input counter trigger edge

This sub-function code is used to set the digital input counter trigger edge value of a module.

Request

| | | | |
|----|--------------------|--------|------------|
| 00 | Address | 1 Byte | 1 ~ 247 |
| 01 | Function code | 1 Byte | 0x46 |
| 02 | Sub-function code | 1 Byte | 0x21 |
| 03 | Edge setting value | 1 Byte | *0x00~0x0F |

*1 = rising edge, 0 = falling edge. For example 0x03 denotes that channels 0~1 are set as rising edge and channels 2~3 are set as falling edge.

Response

| | | | |
|----|--------------------|--------|------------------------|
| 00 | Address | 1 Byte | 1 ~ 247 |
| 01 | Function code | 1 Byte | 0x46 |
| 02 | Sub-function code | 1 Byte | 0x21 |
| 03 | Edge setting value | 1 Byte | 0: OK others: error |

Error Response

| | | | |
|----|----------------|--------|--|
| 00 | Address | 1 Byte | 1 ~ 247 |
| 01 | Function code | 1 Byte | 0xC6 |
| 02 | Exception code | 1 Byte | Refer to the Modbus standard for more details. |

Supported Modules

M-7060/M-7060D/M-7051/M-7051D/M-7052/M-7052D/M-7053/M-7053D/M-7055/M-7055D /M-7041/M-7041D

3.7.7 Sub-function 34 (0x22) Read digital input counter trigger edge value

This sub-function code is used to read the digital input counter trigger edge value of a module.

Request

| | | | |
|----|-------------------|--------|---------|
| 00 | Address | 1 Byte | 1 ~ 247 |
| 01 | Function code | 1 Byte | 0x46 |
| 02 | Sub-function code | 1 Byte | 0x22 |

Response

| | | | |
|----|--------------------|--------|------------|
| 00 | Address | 1 Byte | 1 ~ 247 |
| 01 | Function code | 1 Byte | 0x46 |
| 02 | Sub-function code | 1 Byte | 0x22 |
| 03 | Edge setting value | 1 Byte | *0x00~0x0F |

*1 = rising edge, 0 = falling edge. For example 0x03 denotes that channels 0~1 are set as rising edge and channels 2~3 are set as falling edge.

Error Response

| | | | |
|----|----------------|--------|--|
| 00 | Address | 1 Byte | 1 ~ 247 |
| 01 | Function code | 1 Byte | 0xC6 |
| 02 | Exception code | 1 Byte | Refer to the Modbus standard for more details. |

Supported Modules

M-7060/M-7060D/M-7050/M-7050D/M-7051/M-7051D/M-7052/M-7052D/M-7053/M-7053D/M-7055/M-7055D/M-7041/M-7041D

3.7.8 Sub-function 39 (0x27) Set the power-on value

This sub-function code is used to set the power-on value of a module.

Request

| | | | |
|----|-------------------|--------|------------|
| 00 | Address | 1 Byte | 1 ~ 247 |
| 01 | Function code | 1 Byte | 0x46 |
| 02 | Sub-function code | 1 Byte | 0x27 |
| 03 | Power-on Value | 1 Byte | *0x00~0xFF |

*0x00~0x0F for M-7060/M-7060D

0x00~0x7F for M-7067/M-7067D

Response

| | | | |
|----|-------------------|--------|-------------------------|
| 00 | Address | 1 Byte | 1 ~ 247 |
| 01 | Function code | 1 Byte | 0x46 |
| 02 | Sub-function code | 1 Byte | 0x28 |
| 03 | Power-on value | 1 Byte | 0: OK, others: error |

Error Response

| | | | |
|----|----------------|--------|--|
| 00 | Address | 1 Byte | 1 ~ 247 |
| 01 | Function code | 1 Byte | 0xC6 |
| 02 | Exception code | 1 Byte | Refer to the Modbus standard for more details. |

Supported Modules

M-7060/M-7060D/M-7067/M-7067D/M-7050/M-7050D/M-7055/M-7055D/M-7045/M7045D

3.7.9 Sub-function 40 (0x28) Read the power-on value

This sub-function code is used to read the power-on value of a module.

Request

| | | | |
|----|-------------------|--------|---------|
| 00 | Address | 1 Byte | 1 ~ 247 |
| 01 | Function code | 1 Byte | 0x46 |
| 02 | Sub-function code | 1 Byte | 0x28 |

Response

| | | | |
|----|-------------------|--------|------------|
| 00 | Address | 1 Byte | 1 ~ 247 |
| 01 | Function code | 1 Byte | 0x46 |
| 02 | Sub-function code | 1 Byte | 0x28 |
| 03 | Power-on value | 1 Byte | *0x00~0xFF |

*0x00~0x0F for M-7060/M-7060D

0x00~0x7F for M-7067/M-7067D

Error Response

| | | | |
|----|----------------|--------|--|
| 00 | Address | 1 Byte | 1 ~ 247 |
| 01 | Function code | 1 Byte | 0xC6 |
| 02 | Exception code | 1 Byte | Refer to the Modbus standard for more details. |

Supported Modules

M-7060/M-7060D/M-7067/M-7067D/M-7050/M-7050D/M-7055/M-7055D/M-7045/M7045D

3.7.10 Sub-function 41 (0x29) Set DI/O active states

This sub-function code is used to set the DI/O active states of a module.

Request

| | | | |
|----|--------------------|--------|---|
| 00 | Address | 1 Byte | 1 ~ 247 |
| 01 | Function code | 1 Byte | 0x46 |
| 02 | Sub-function code | 1 Byte | 0x29 |
| 03 | DI/O active states | 1 Byte | *0x00~0x03 Refer to the table below. |

*0x00~0x03 for M-7060/M-7060D

0x00 and 0x02 for M-7067/M-7067D

DI/O active states:

| | | | | | | | |
|----------|---|---|---|---|---|-----|-----|
| 7 | 6 | 5 | 4 | 3 | 2 | 1 | 0 |
| Reserved | | | | | | OAS | IAS |

| Key | Description |
|-----|---|
| OAS | DO active state 0: output value 1 for relay active output value 0 for relay inactive 1: output value 0 for relay active output value 1 for relay inactive |
| IAS | DI active state 0: input value 1 for non-signal or the low voltage; input value 0 for high voltage 1: input value 0 for non-signal or the low voltage; input value 1 for high voltage |

Response

| | | | |
|----|-------------------|--------|------------------------|
| 00 | Address | 1 Byte | 1 ~ 247 |
| 01 | Function code | 1 Byte | 0x46 |
| 02 | Sub-function code | 1 Byte | 0x29 |
| 03 | Power-on value | 1 Byte | 0: OK others: error |

Error Response

| | | | |
|----|----------------|--------|--|
| 00 | Address | 1 Byte | 1 ~ 247 |
| 01 | Function code | 1 Byte | 0xC6 |
| 02 | Exception code | 1 Byte | Refer to the Modbus standard for more details. |

Supported Modules

M-7060/M-7060D/M-7067/M-7067D/M-7050/M-7050D/M-7051/M-7051D/M-7052/M-7052D/M-7053/M-7053D/M-7055/M-7055D/M-7041/M-7041D/M-7045/M7045D

Note: After using the command, the DIO active states will immediately change and will simultaneously clear the DI counter and latch values.

3.7.11 Sub-function 42 (0x2A) Read DI/O active states

This sub-function code is used to read the DI/O active states of a module.

Request

| | | | |
|----|-------------------|--------|---------|
| 00 | Address | 1 Byte | 1 ~ 247 |
| 01 | Function code | 1 Byte | 0x46 |
| 02 | Sub-function code | 1 Byte | 0x2A |

Response

| | | | |
|----|--------------------|--------|------------|
| 00 | Address | 1 Byte | 1 ~ 247 |
| 01 | Function code | 1 Byte | 0x46 |
| 02 | Sub-function code | 1 Byte | 0x2A |
| 03 | DI/O active status | 1 Byte | *0x00~0x03 |

*0x00~0x03 for M-7060/M-7060D

0x00 and 0x02 for M-7067/M-7067D

Error Response

| | | | |
|----|----------------|--------|--|
| 00 | Address | 1 Byte | 1 ~ 247 |
| 01 | Function code | 1 Byte | 0xC6 |
| 02 | Exception code | 1 Byte | Refer to the Modbus standard for more details. |

Supported modules

M-7060/M-7060D/M-7067/M-7067D/M-7050/M-7050D/M-7051/M-7051D/M-7052/M-7052D/M-7053/M-7053D/M-7055/M-7055D/M-7041/M-7041D/M-7045/M7045D

3.8 Modbus Address Mapping

| Address | Channel | Description | Attribute |
|----------------------------|--------------|-------------------------------|-----------|
| 00001~00032 | DO 0 ~ DO 31 | Current DO value | R/W |
| 00033~00064 | DI 0 ~ DI 31 | Current DI value | R |
| 00065~00096 | 0~31 | DIO Latch high value | R |
| 00097~00128 | 0~31 | DIO Latch low value | R |
| 00257 | | Write 1 to clear latch values | W |
| 00513~00544 | DI0 ~ DI31 | Write 1 to clear DI counter | W |
| 30001~30032 40001~40032 | DI 0 ~ DI 31 | DI counter value | R |

4. Troubleshooting

If you are having difficulty using the I-7000 or M-7000 module, here are some suggestions that may help. If you cannot find the answers you need in these guides, contact ICP DAS Product Support. Contact information is located in Section 1.14.

4.1 Communicating with the module

If you attempt to communicate with the module and receive no response, first check the following:

- Ensure that the supplied power is within the range of +10 to +30 V DC. If the supplied power is OK, then the power LED should be on.
- When the module receives a command, the power LED is set to “off”. The power LED is shown as “on” after the module responds. This method can be used to check whether the module has received a command sent from the host.
- If possible, use another device to check whether the host can communicate with the device through the same RS-485 network.
- If the host is a PC installed with a Windows operating system, then execute the DCON Utility to determine whether the module can be found. The DCON Utility can be downloaded from the ICP DAS website <http://www.icpdas.com>. The DCON Utility documentation can be found in the **”Getting Started For I-7000 Series Modules”** manual.
- Set the module to “INIT mode” and communicate with the module using the following settings: address 00, Baud Rate 9600bps and no checksum. See Section A.1 for details.

A. Appendix

A.1 INIT Mode

Each I-7000 and M-7000 module has a built-in EEPROM to store configuration information such as module address, type code, Baud Rate, etc. Occasionally, the configuration of a module may be forgotten and there are no visual indications of the configuration of the module. It is difficult to communicate with the module when the configuration of the module is unknown. To help avoid this problem, the I-7000 and M-7000 series has a special mode called **“INIT mode”**. When the module is powered on in **“INIT mode”** the configuration of the module is reset as follows, allowing it to be operated as normal.

1. Address: 00
2. Baud Rate: 9600 bps
3. No checksum
4. Protocol: DCON

The configuration information stored in the EEPROM is not changed and can be read by sending the \$002(CR) command at 9600bps.

There are commands that require the module to be in INIT mode. They are:

1. %AANN TTCCFF when changing the Baud Rate and checksum settings. See Section 2.1 for details.
2. \$AAPN, see Section 2.20 for details.

Originally, the INIT mode is accessed by connecting the INIT* terminal to the GND terminal. New I-7000 and M-7000 modules have the INIT switch located on the rear side of the module to allow easier access to the INIT mode. For these modules, INIT mode is accessed by sliding the INIT switch to the Init position as shown below.

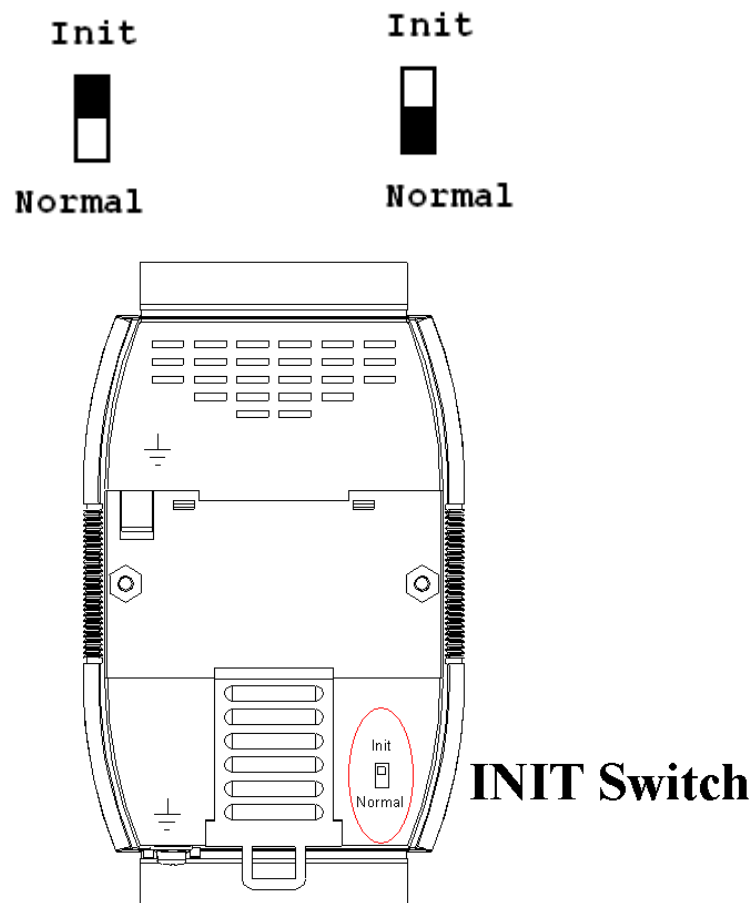

A.2 Dual Watchdog Operation

Dual Watchdog = Module Watchdog + Host Watchdog

The Module Watchdog is a hardware reset circuit that monitors the operating status of the module. While working in harsh or noisy environments, the module may be shut down by external signals. The circuit allows the module to work continuously without disruption.

The Host Watchdog is a software function that monitors the operating status of the host. Its purpose is to prevent problems due to network/communication errors or host malfunctions. When a host watchdog timeout occurs, the module will reset all outputs to a safe state in order to prevent any erroneous operations of the controlled target.

I-7000 and M-7000 series modules include an internal Dual Watchdog, making the control system more reliable and stable.

For more information regarding the Dual Watchdog, please refer to Chapter 5 of the “**Getting Started For I-7000 Series Modules**” manual that can be downloaded from the ICP DAS website <http://www.icpdas.com>.

A.3 Frame Ground

Electronic circuits are constantly vulnerable to Electro-Static Discharge (ESD), which become worse in a continental climate area. Some I-7000 and M-7000 modules feature a new design for the frame ground, which provides a path for bypassing ESD, allowing enhanced static protection (ESD) capability and ensures that the module is more reliable.

Either of the following options will provide a better protection for the module:

1. If the module is DIN rail mounted, connect the DIN rail to the earth ground because the DIN rail is in contact with the upper frame ground as shown in the figure below.
2. Alternatively, connect the lower frame ground terminal to a wire and connect the wire to the earth ground, as shown in the figure below.

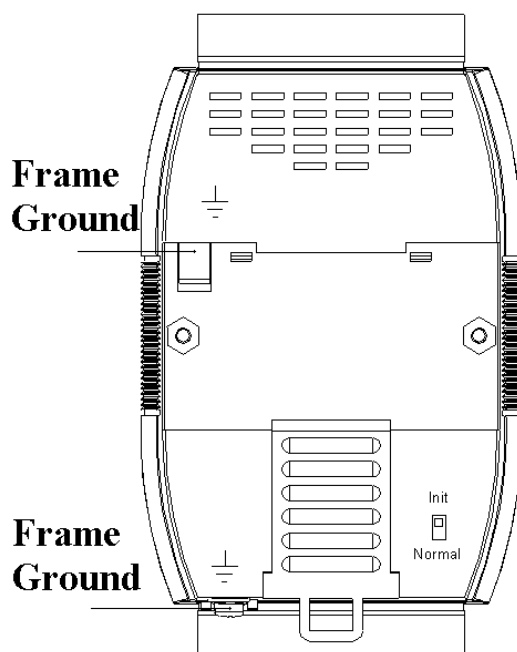

New DIN rail models are available that can easily be connected to the earth ground. Each is made of stainless steel, which is stronger than those made of aluminum. There is a screw at one end and a ring terminal is included as shown in the figure below. Refer to Section 1.13.1 for more information about the new DIN rail models.

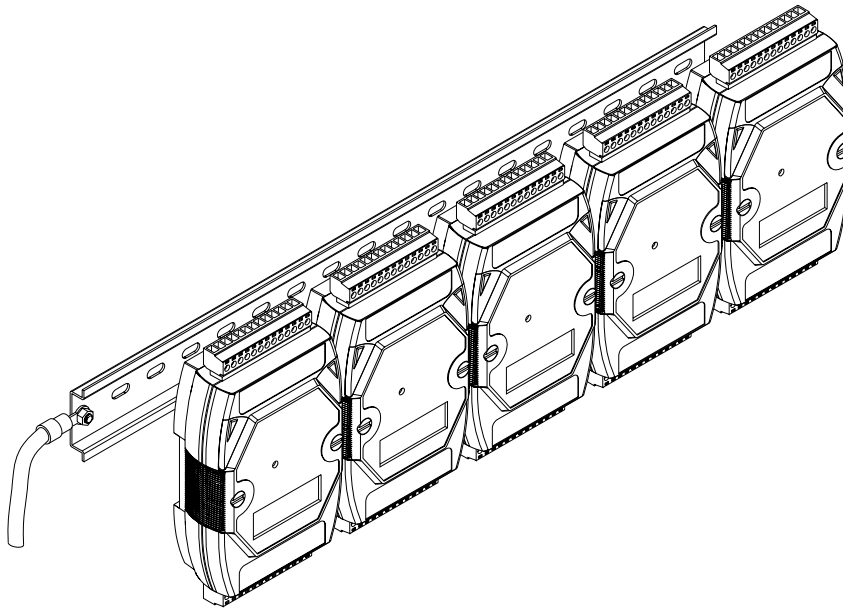

A.4 Node Information Area

Each I-7000 and M-7000 module has a built-in EEPROM to store configuration information such as module address, type code, Baud Rate, etc. One minor drawback is that there are no visual indications of the configuration of the module. New I-7000 and M-7000 modules include node information areas that are protected by a cover, as shown below, and can be used to make a written record of the node information, such as module address, Baud Rate, etc. To access the node information areas, first slide the covers outward, as shown in the figure below.

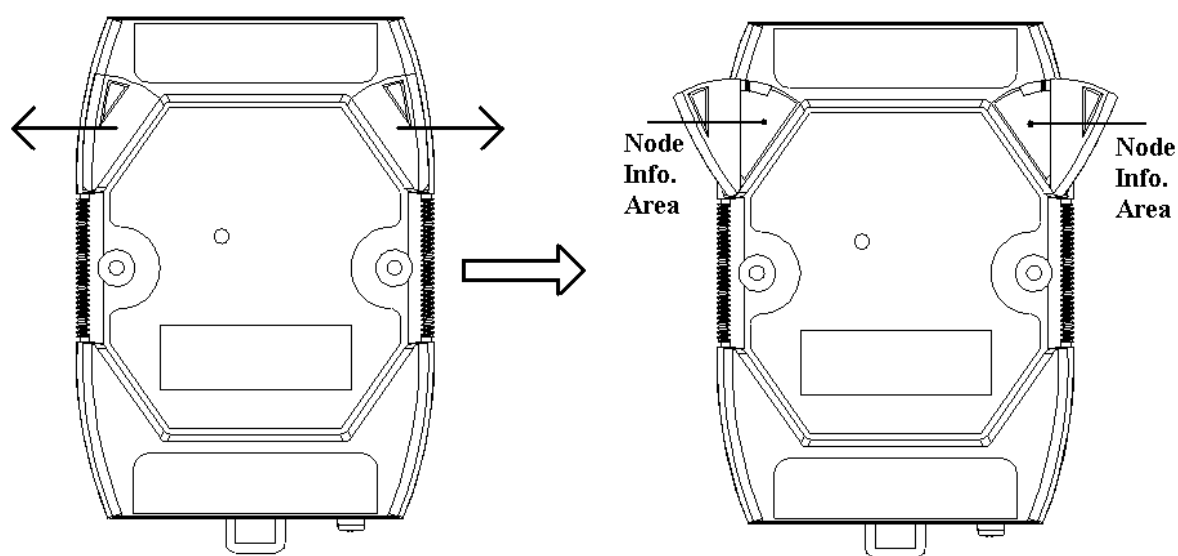

A.5 Reset Status

The reset status of a module is set when the module is powered-on or when the module is reset by the module watchdog. It is cleared after the responding of the first \$AA5 command. This can be used to check whether the module had been reset. When the \$AA5 command responds that the reset status is cleared, that means the module has not been reset since the last \$AA5 command was sent. When the \$AA5 command responds that the reset status is set and it is not the first time \$AA5 command is sent, it means the module has been reset and the digital output value had been changed to the power-on value.

A.6 Safe Value and Power-on Value of Digital Output

Besides setting by the set digital output commands, the digital outputs can be set under two other conditions.

When the host watchdog is enabled and a host watchdog timeout occurs, the “**safe value**” is loaded into the digital output ports. The set digital output commands have no effect on the digital output ports until the host watchdog timeout status is cleared. The host watchdog timeout status is saved in the EEPROM. The status is not changed even after power-on reset. It can be cleared only by the reset host watchdog timeout status command ~AA1. See Section A.2 for host watchdog details.

When the module is powered on and the host watchdog timeout status is cleared, the “**power-on value**” is loaded into the digital output ports. If the host watchdog timeout status is not cleared on power-on, then the safe value is loaded into the digital output ports.

Both the safe value and power-on value are set by the ~AA5V command. Refer to Section 2.30 for details.

A.7 Latched Digital Input

The I-7000 and M-7000 DIO modules provide commands to read the latched high digital input and latched low digital input status. Following is an example to show the usefulness of the latched digital input. When we want to read the key stroke of a key switch connected to the digital input channel of a module, the input signal of the key stroke is a pulse signal as shown in the following figure.

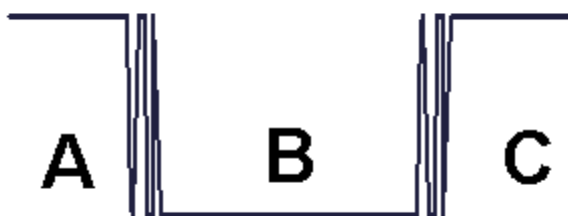

If we just use the read digital input status command to read the signal and we cannot send the command during the B period due to some reasons, then we will lose the key stroke information. However, with the read latched digital input command, we can still get the key stroke information even we are not able to send command in B period. For details of the read latched digital input command, please refer to Sections 2.17 and 3.1.

A.8 DN Module

The DN modules are the I/O extension of the I-7000 and M-7000 modules. They can drive more power and heavy load. User may use I-7000 and M-7000 modules to control the DN modules to drive the loads. Following is an example of using the I-7043 with the DN module.

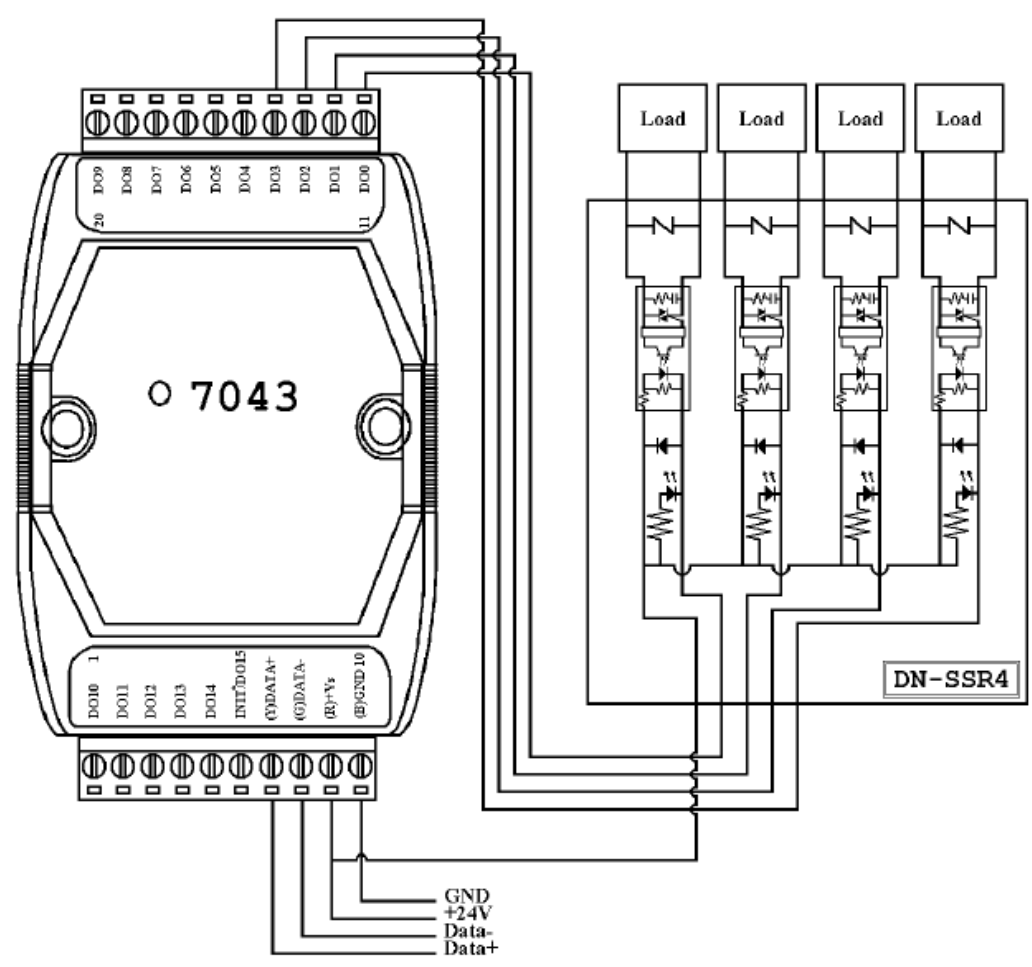

A.8.1 DN-SSR4

| | |
|--------------------------------|--|
| Output Channel | 4 solid state relay contact |
| Output Specifications | |
| Type | Zero-cross AC solid-state relay output |
| Rated Load Voltage | 200 to 240 VAC |
| Rated Load Current | 4 A _{rms} |
| Surge Current | 50 A |
| Max. Off-State Leakage Current | 5.0 mA |
| Operate Time | 1/2 cycle of voltage sine wave + 1ms |
| Input Impedance | 1.5K Ohms |
| Power Input | +24 VDC |
| DIN-Rail Mounted | |

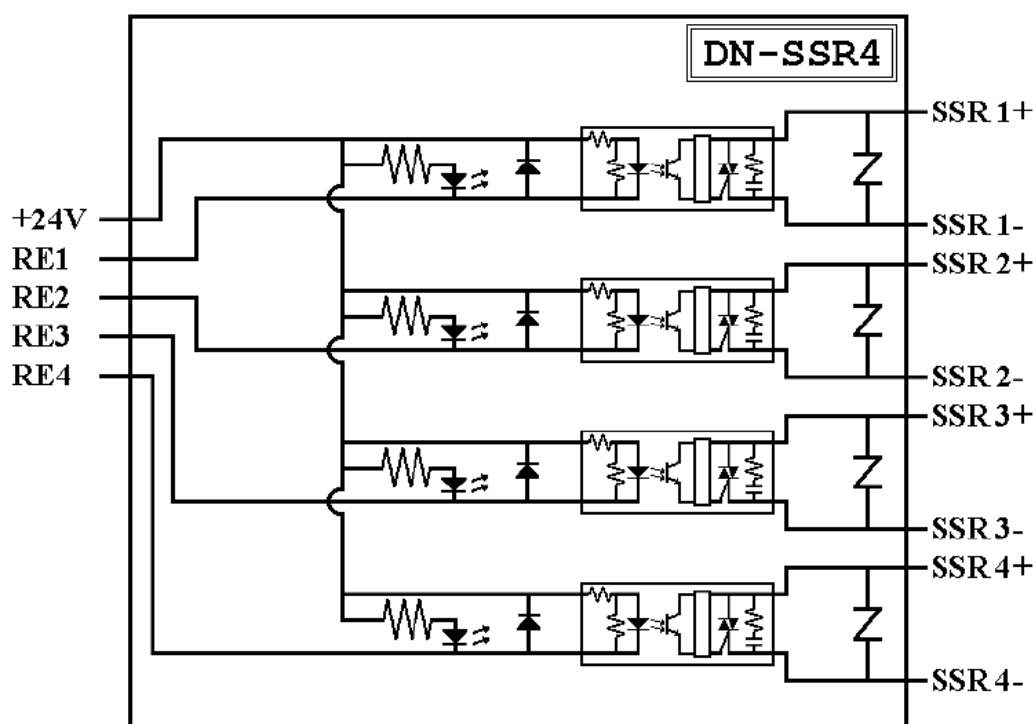

A.8.2 DN-PR4

| | |
|------------------------|---------------------------------------|
| Output Channel | 4 relay contact |
| Output Specifications | |
| Type | 1 Form C relay contact |
| Nominal Load | 5A@250VAC, 5A@30VDC |
| Max. Switching Power | 1250 VA |
| Max. Switching Voltage | 250 VAC, 150 VDC |
| Max. Switching Current | 5 A |
| Mechanical Life | 10 x 10 ⁶ operations min. |
| Electric Life | 100 x 10 ³ operations min. |
| Operate/Release Time | Max. 10 ms / 5 ms |
| Dielectric Strength | 2000 VAC 1 minute |
| Nominal Coil Power | 360 mW |
| Power Input | +24 VDC |
| DIN-Rail Mounted | |

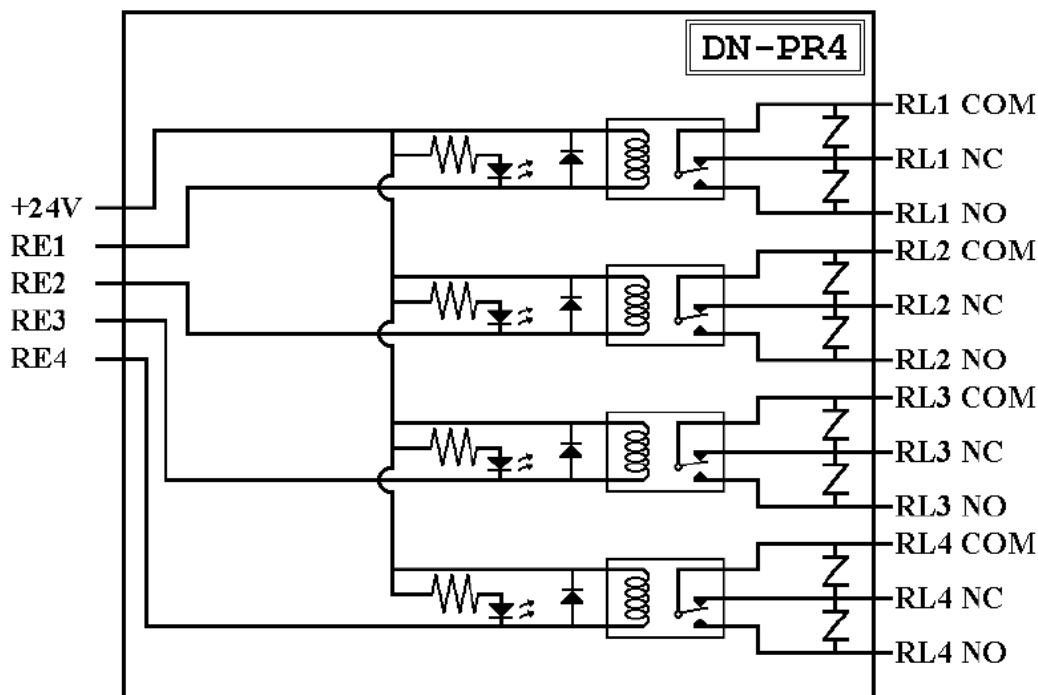

A.8.3 RM-104, RM-108, and RM-116

| | |
|------------------------|------------------------|
| Output Channel | 4/8/16 relay contact |
| Output Specifications | |
| Type | 1 Form C relay contact |
| Rated Load | 16A@250VAC |
| Max. Switching Voltage | 400 VAC |
| Max. Peak Current | 30 A |
| Contact Material | AgCdO |
| Min. Life | 100,000 operations |
| Dimensions | |
| RM-104 | 78 mm x 77 mm |
| RM-108 | 135 mm x 77 mm |
| RM-116 | 270 mm x 77 mm |
| Power Input | +24 VDC |
| DIN-Rail Mounted | |

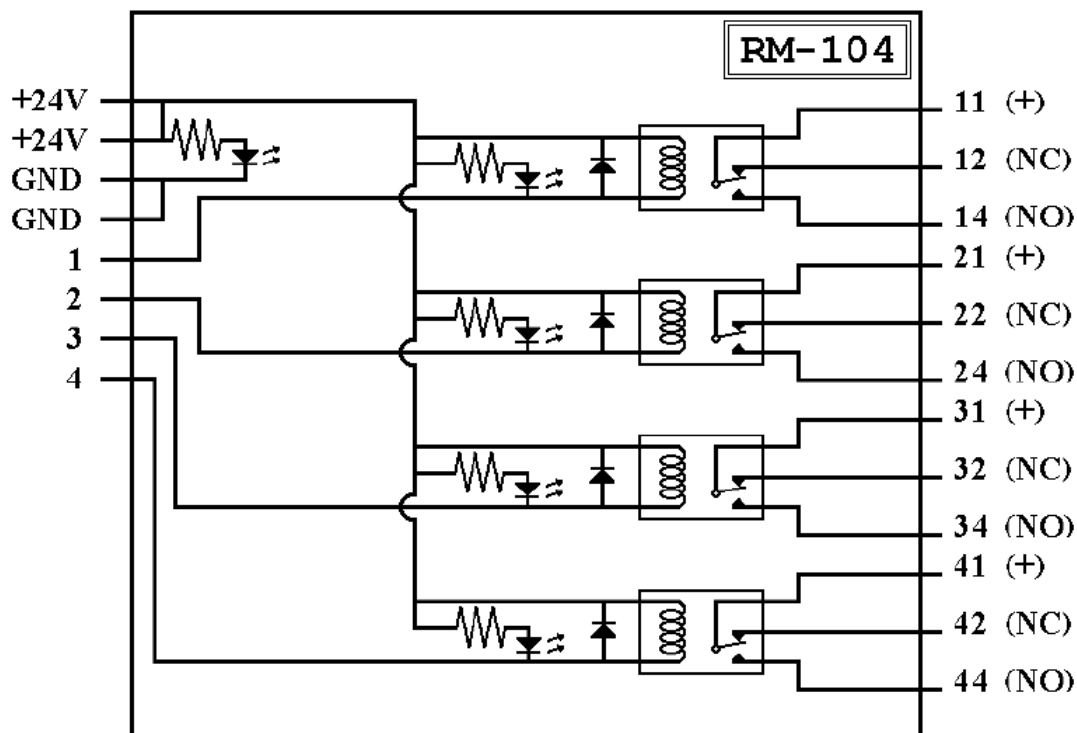

A.8.4 RM-204, RM-208, RM-216

| | |
|------------------------|------------------------|
| Output Channel | 4/8/16 relay contact |
| Output Specifications | |
| Type | 2 Form C relay contact |
| Rated Load | 5A@250VAC |
| Max. Switching Voltage | 400 VAC |
| Max. Peak Current | 10 A |
| Contact Material | AgNi |
| Min. Life | 100,000 operations |
| Dimensions | |
| RM-204 | 78 mm x 77 mm |
| RM-208 | 135 mm x 77 mm |
| RM-216 | 270 mm x 77 mm |
| Power Input | +24 VDC |
| DIN-Rail Mounted | |

