

I-7012/12D/12F/12FD, I-7014D, I-7017/17F User's Manual

Warranty

All products manufactured by ICP DAS are warranted against defective materials for a period of one year from the date of delivery to the original purchaser.

Warning

ICP DAS assume no liability for damages consequent to the use of this product. ICP DAS reserves the right to change this manual at any time without notice. The information furnished by ICP DAS is believed to be accurate and reliable. However, no responsibility is assumed by ICP DAS for its use, nor for any infringements of patents or other rights of third parties resulting from its use.

Copyright

Copyright 1999 by ICP DAS. All rights are reserved.

Trademark

The names used for identification only maybe registered trademarks of their respective companies.

Date:2001-11

Table of Contents

1. Introduction	5
1.1 More Information.....	5
1.2 Pin Assignment	6
1.3 Specifications.....	9
1.4 Block Diagram	12
1.5 Wire Connection	14
1.6 Quick Start	16
1.7 Default Setting	16
1.8 Jumper Setting	16
1.9 Calibration	17
1.10 Configuration Tables.....	18
2. Command	20
2.1 %AANNTTCCFF	24
2.2 #**	26
2.3 #AA.....	27
2.4 #AAN.....	28
2.5 \$AA0.....	29
2.6 \$AA1.....	30
2.7 \$AA2.....	31
2.8 \$AA4.....	32
2.9 \$AA5VV	33
2.10 \$AA6.....	34

2.11 \$AA8	35
2.12 \$AA8V	36
2.13 \$AA9(Data)	37
2.14 \$AAA	38
2.15 \$AAF	39
2.16 \$AAM	40
2.17 ~AAO(Data)	41
2.18 ~AAEV	42
2.19 @AADI	43
2.20 @AADO(Data)	44
2.21 @AAEAT	45
2.22 @AAHI(Data)	46
2.23 @AALO(Data)	47
2.24 @AADA	48
2.25 @AACA	49
2.26 @AARH	50
2.27 @AARL	51
2.28 @AARE	52
2.29 @AACE	53
2.30 \$AA3	54
2.31 \$AA5	55
2.32 \$AA6(SL)(SH)	56
2.33 \$AA7(TL)(TH)	57
2.34 \$AAA	58

2.35 \$AAAV	59
2.36 ~**	60
2.37 ~AA0	61
2.38 ~AA1	62
2.39 ~AA2	63
2.40 ~AA3EVV	64
2.41 ~AA4	65
2.42 ~AA5PPSS	66
3. Application Note	67
3.1 INIT* pin Operation	67
3.2 Module Status	67
3.3 Dual Watchdog Operation	68
3.4 Digital Input and Event Counter	68
3.5 Digital Output	68
3.6 High/Low Alarm	69
3.7 Transmitter	69
3.8 Linear Mapping	70

1. Introduction

I-7000 is a family of network data acquisition and control modules. They provide analog-to-digital, digital-to-analog, digital input/output, timer/counter and other functions. These modules can be remote controlled by a set of commands. The common features of analog input modules are given as follows :

- 3000VDC Isolated analog input.
- 24-bits sigma-delta ADC to provide excellent accuracy.
- Software calibration

The I-7012 is a single channel analog input module with high/low alarm function. The I-7012D is the I-7012 with a 4½ digit LED display. The I-7012F/12FD is a I-7012/12D with high speed analog input function. The I-7014D is I-7012D with Linear Mapping function and support +15V loop power for transmitter. The I-7017 is a 8-channel analog input module. The I-7017F is I-7017 with high speed analog input function.

1.1 More Information

Refer to “**I-7000 Bus Converter User Manual**” chapter 1 for more information as following:

1.1 I-7000 Overview

1.2 I-7000 Related Documentation

1.3 I-7000 Command Features

1.4 I-7000 System Network Configuration

1.5 I-7000 Dimension

1.2 Pin Assignment

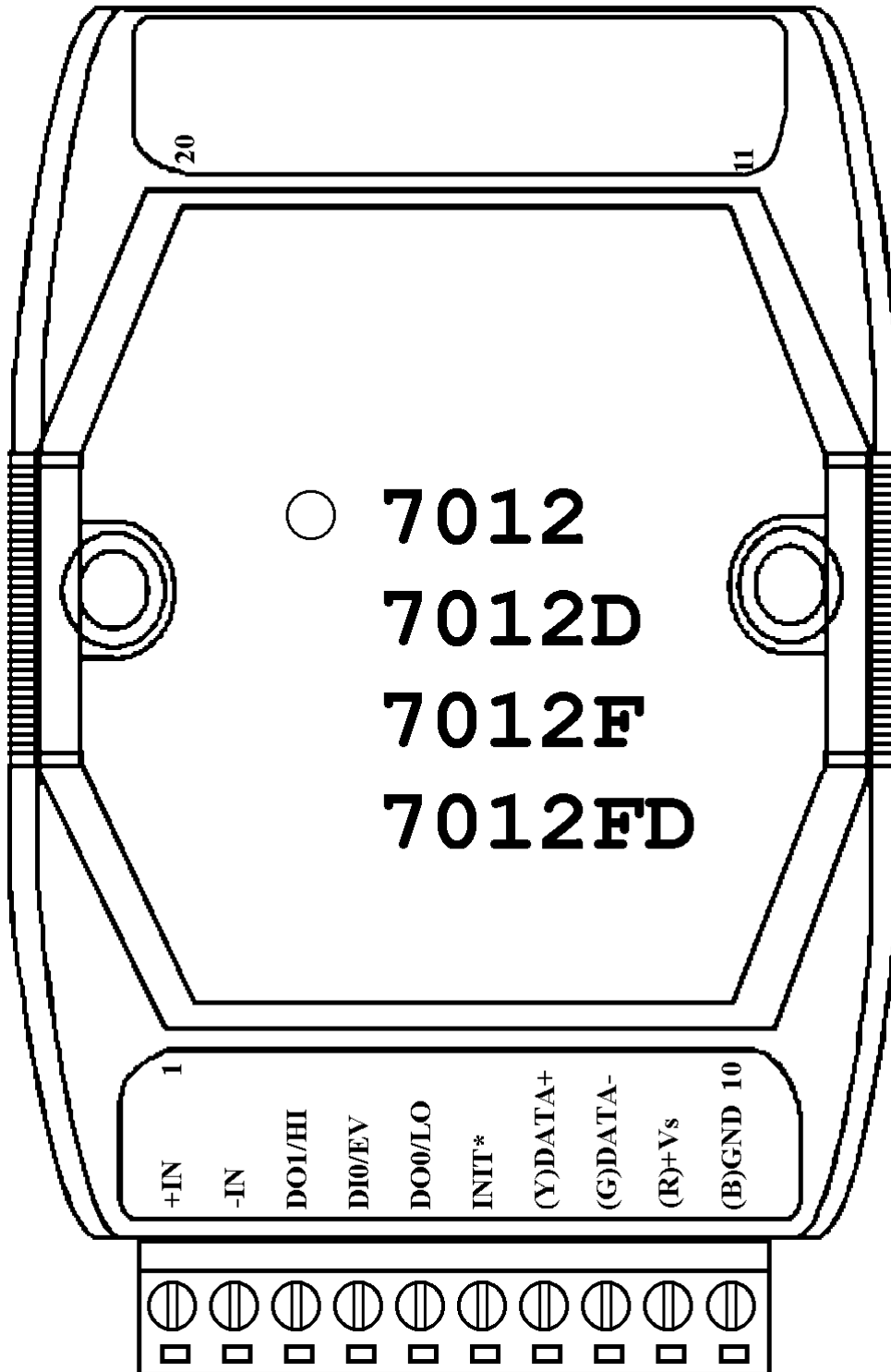

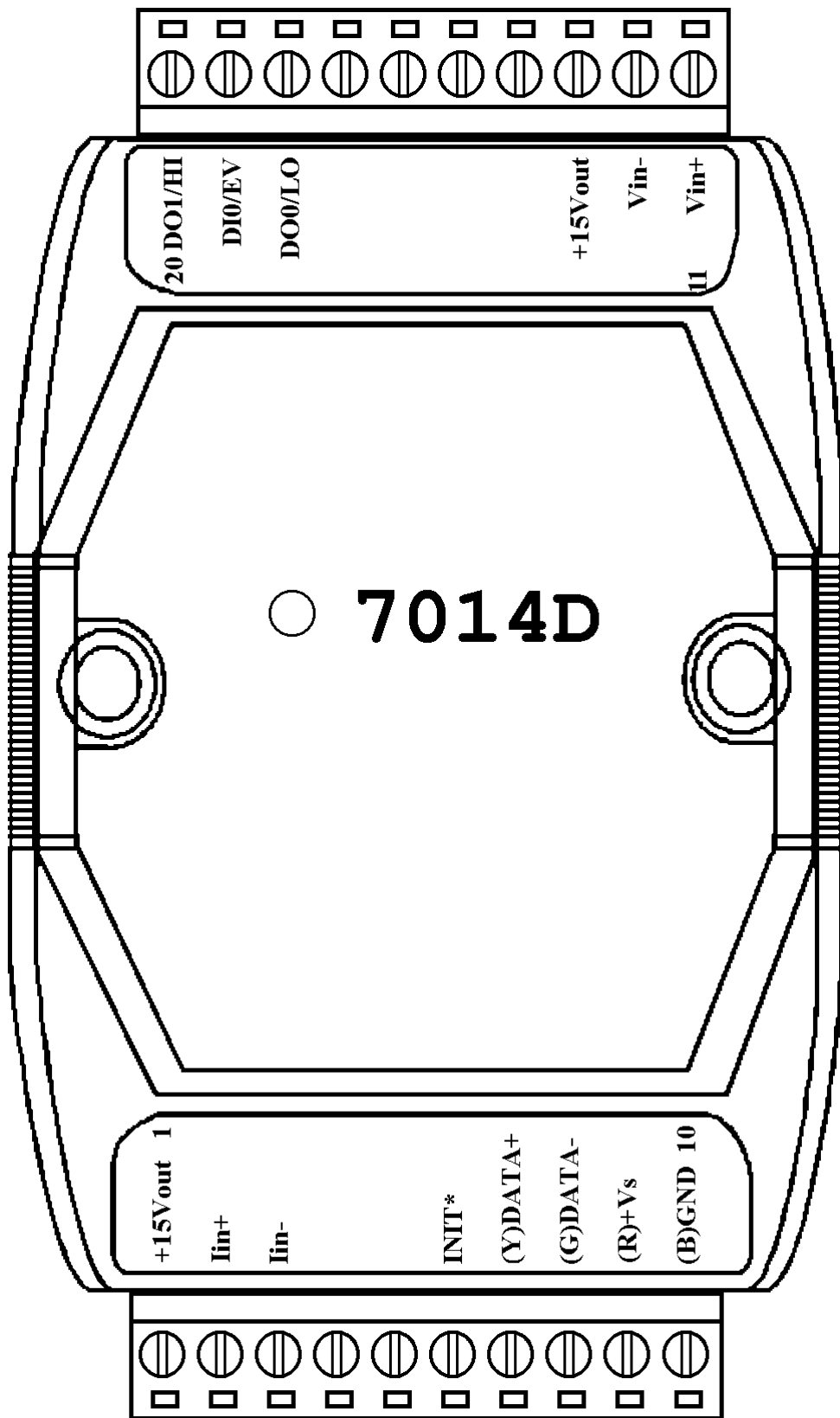

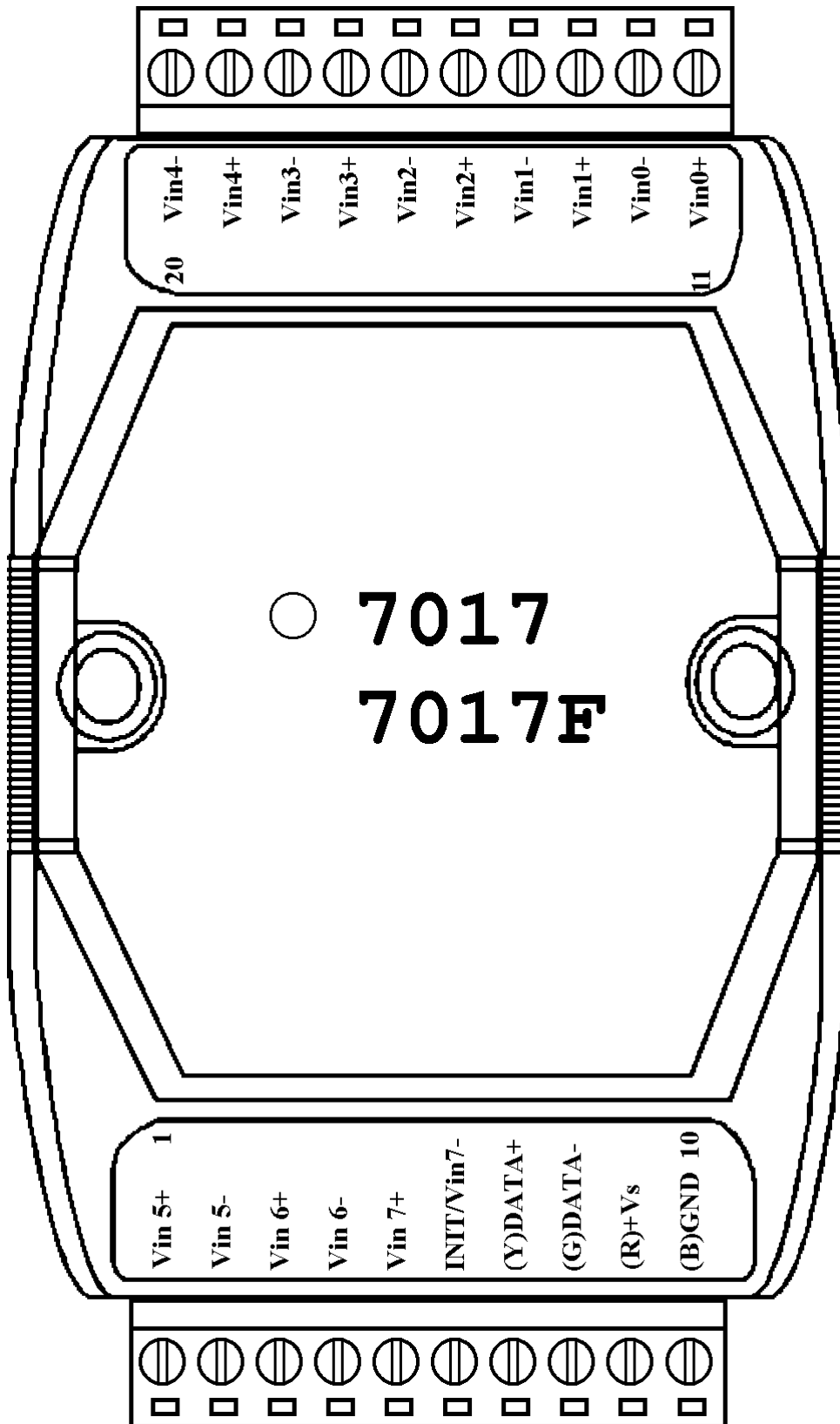

1.3 Specifications

I-7012/I-7012D

Analog Input

Input Channel : 1

Input Type :

mV, V, mA(with external
125 ohms resistor)

Sampling Rate :

10 Samples/Second

Bandwidth : 5.24 Hz

Accuracy : $\pm 0.05\%$

Zero Drift : $20\mu\text{V}/^\circ\text{C}$

Span Drift : $25\text{ppm}/^\circ\text{C}$

CMR : 86dB

Input Impedance : 20M Ohms

Isolation : 3000VDC

Digital Output

Output Channel : 2

Open Collector to 30V

Output Load : sink 30mA max

Power Dissipation : 300mW

Digital Input

Input Channel : 1

Logic Level 0 : +1V max

Logic Level 1 : +3.5 to 30V

Event Counter

Max Input Frequency : 50 Hz

Min. Pulse Width : 1 mS

Displayed LED

4½ digits (for I-7012D)

Power Supply

Input : +10 to +30VDC

Consumption :

1.3W for I-7012

1.9W for I-7012D

I-7012F/I-7012FD

Analog Input

Input Channel : 1

Input Type :

mV, V, mA(with external
125 ohms resistor)

Fast Mode Sampling Rate :

100 Samples/Second

Fast Mode Bandwidth : 52.4 Hz

Fast Mode Accuracy : $\pm 0.25\%$

Normal Mode :

Same as I-7012

Input Impedance : 20M Ohms

Isolation : 3000VDC

Digital Input/Output

Same as I-7012

Displayed LED

4½ digits (for I-7012FD)

Power Supply

Input : +10 to +30VDC

Consumption :

1.3W for I-7012F

1.9W for I-7012FD

I-7014D

Analog Input

Input Channel and Type:

1 Voltage Input : mV, V

1 Current Input : mA

Sampling Rate :

10 Samples/Second

Bandwidth : 5.24 Hz

Accuracy : $\pm 0.05\%$

Zero Drift : $20\mu\text{V}/^\circ\text{C}$

Span Drift : 25ppm/ $^\circ\text{C}$

CMR@50/60Hz : 150dB min

Input Impedance :

Voltage Input : 30K Ohms

Current Input : 125 Ohms

Isolation : 3000VDC

Excitation Voltage Output

Output Rating : 30mA@15V

Digital Input/Output

Same as I-7012

Displayed LED

4½ digits

Power Supply

Input : +10 to +30VDC

Consumption : 1.9W

I-7017

Analog Input

Input Channel :

8 differential or 6 differential and 2 single-ended by jumper select.

Analog Input Type :

mV, V, mA(with external 125 ohms resistor)

Sampling Rate :

10 Samples/Second

Bandwidth : 15.7 Hz

Accuracy : $\pm 0.1\%$

Zero Drift : $20\mu\text{V}/^\circ\text{C}$

Span Drift : $25\text{ppm}/^\circ\text{C}$

CMR : 86dB

Input Impedance : 20M Ohms

Overvoltage Protection : $\pm 35\text{V}$

Isolation : 3000VDC

Power Supply

Input : +10 to +30VDC

Consumption : 1.3W

I-7017F

Analog Input

Input Channel :

8 differential or 6 differential and 2 single-ended by jumper select.

Analog Input Type :

mV, V, mA(with external 125 ohms resistor)

Fast Mode Sampling Rate :

75 Samples/Second

Fast Mode Bandwidth : 78.7 Hz

Fast Mode Accuracy : $\pm 0.5\%$

Normal Mode:

Same as I-7017

Input Impedance : 20M Ohms

Overvoltage Protection : $\pm 35\text{V}$

Isolation : 3000VDC

Power Supply

Input : +10 to +30VDC

Consumption : 1.3W

1.4 Block Diagram

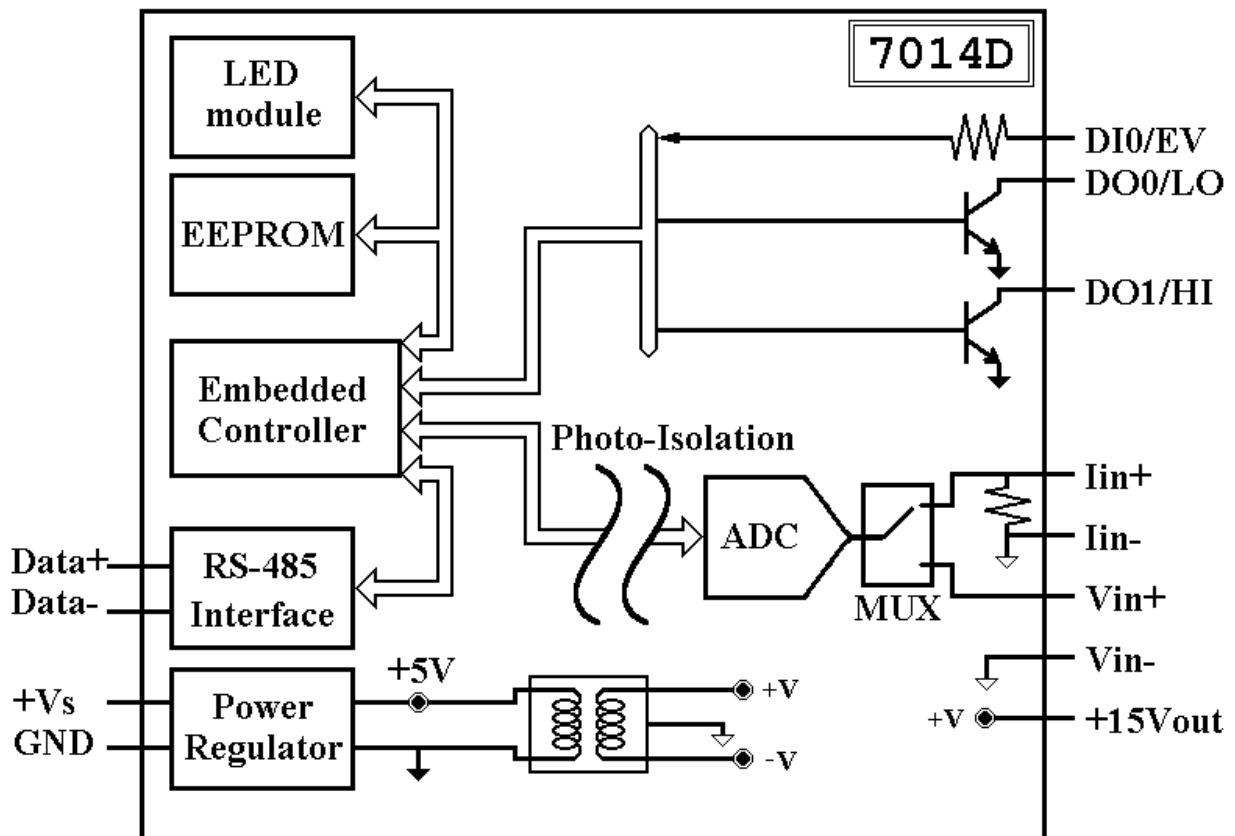
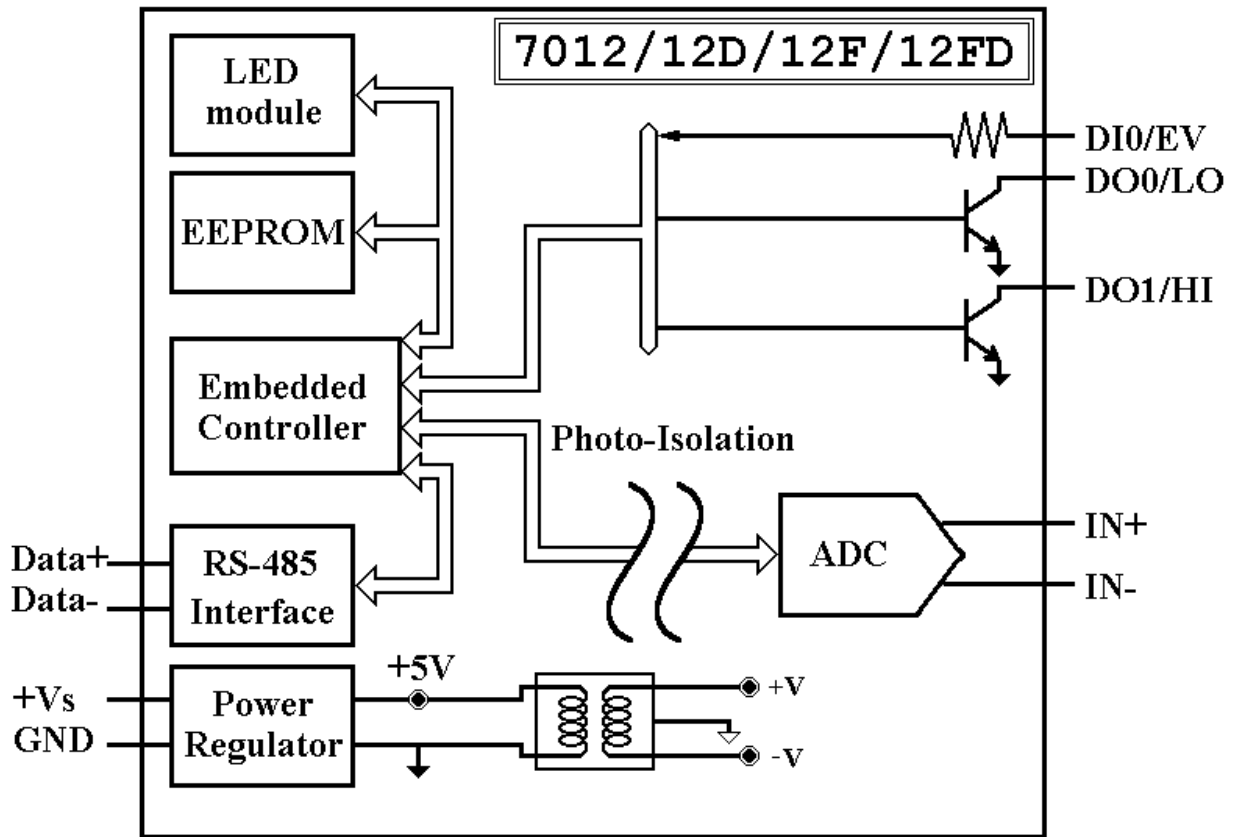

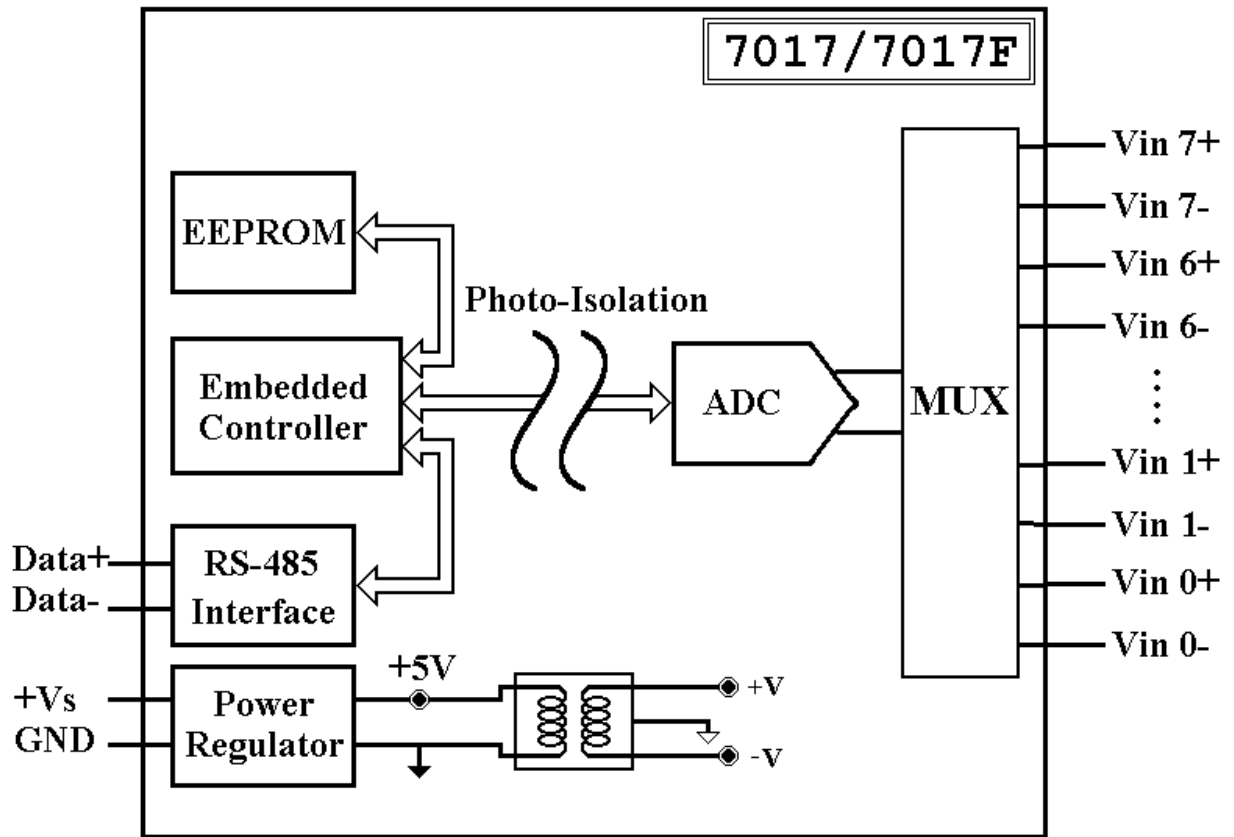

1.5 Wire Connection

I-7012/12D/12F/12FD Analog Input Wire Connection

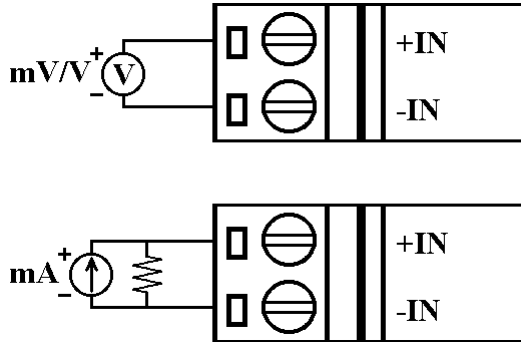

I-7014D Analog Input Wire Connection

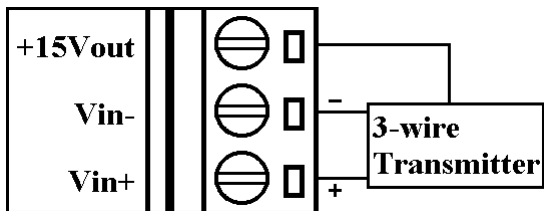
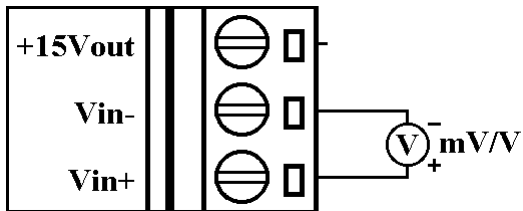
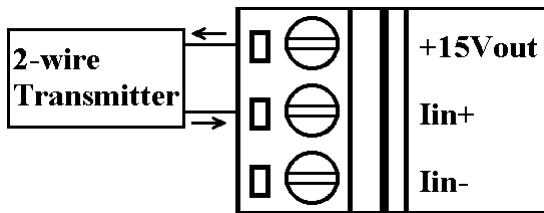
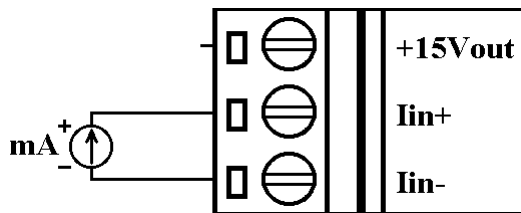

I-7012/12D/12F/12FD/14D Digital Input Wire Connection

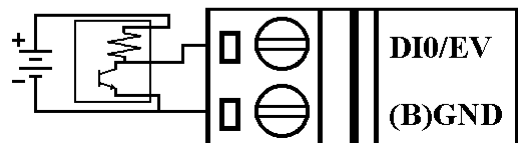
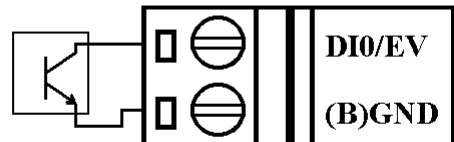
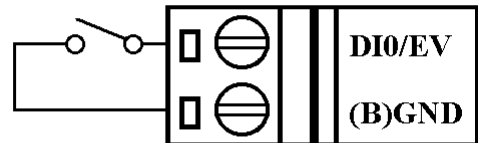
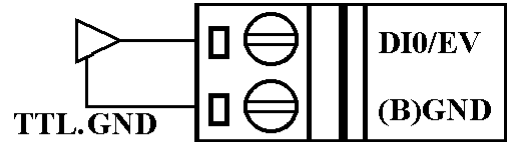

I-7012/12D/12F/12FD/14D Digital Output Wire Connection

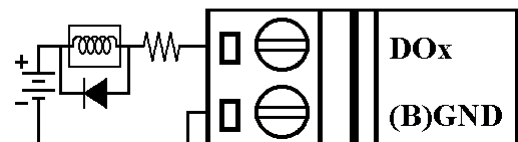
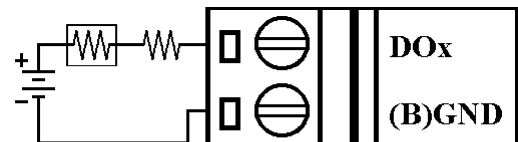

I-7017/17F Analog Input Channel 0 to 5 Wire Connection

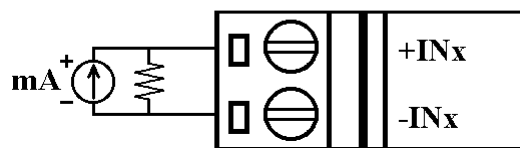
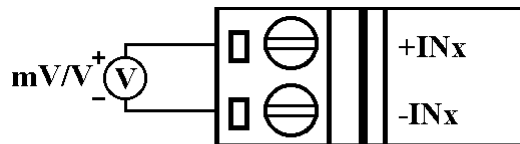

I-7017/17F Analog Input Channel 6 and 7 Wire Connection, while the jumper JP1 setting is 8 differential mode.

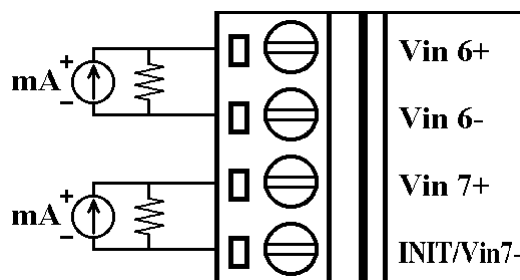
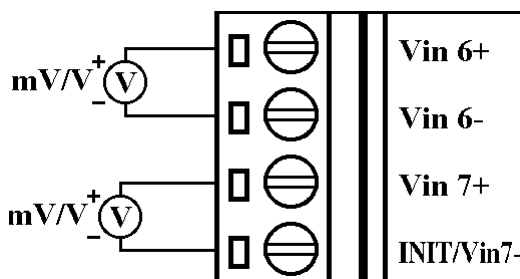

I-7017/17F Analog Input Channel 6 and 7 Wire Connection, while the jumper JP1 setting is INIT* mode.

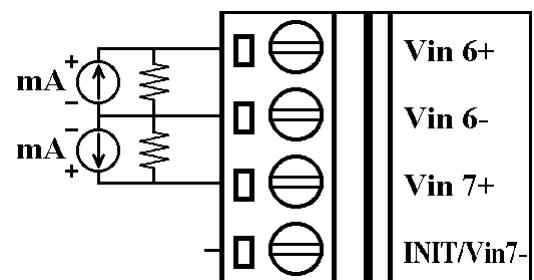
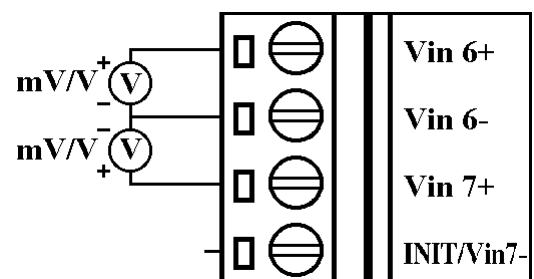

1.6 Quick Start

Refer to “**I-7000 Bus Converter User Manual**” and “**Getting Start**” for more detail.

1.7 Default Setting

Default setting for I-7012/12D/12F/12FD/14D/17/17F :

- Address : 01
- Analog Input Type : Type 08, -10 to +10 V
- Baudrate : 9600 bps
- 60Hz filter rejection, Checksum disable, engineer unit format
- I-7017/17F set as 6 differential and 2 single-ended mode
- I-7012F and I-7017F set as Fast Mode

1.8 Jumper Setting

I-7017/17F : Jumper JP1 for select the pin INIT*/Vin 7-

Select 8 differential JP1  NIT*/Vin7- is set to Vin7-

Select INIT* mode, JP1  Vin7- is set to INIT*

1.9 Calibration

Don't Perform Calibrate Until You Really Understand.

Calibration Requirement for I-7012/12D/12F/12FD/14D/17/17F, While calibrate type 0D, the I-7012/12D/12F/12FD/17/17F need connect external shunt resistor, 125 ohms, 0.1% (Ref *Sec.1.5*).

Type Code	08	09	0A	0B	0C	0D
Zero Input	0 V	0 V	0 V	0 mV	0 mV	0 mA
Span Input	+10 V	+5 V	+1 V	+500 mV	+150 mV	+20 mA

Calibration Sequence :

- 1 Connect calibration voltage/current to module's input. For I-7017/17F, connect to channel 0. (Wire connect ref *Sec.1.5*)
- 2 Warm-Up for 30 minutes
- 3 Setting Type to 08 -> Ref *Sec.2.1*.
- 4 Enable Calibration -> Ref *Sec.2.18*.
- 5 Apply Zero Calibration Voltage
- 6 Perform Zero Calibration Command -> Ref *Sec.2.6*.
- 7 Apply Span Calibration Voltage
- 8 Perform Span Calibration Command -> Ref *Sec.2.5*.
- 9 Repeat step4 to step8 three times.

1.10 Configuration Tables

Configuration Table of I-7012/12F/12D/12FD/14D/17/17F :

Baudrate Setting (CC)

Code	03	04	05	06	07	08	09	0A
Baudrate	1200	2400	4800	9600	19200	38400	57600	115200

Analog Input Type Setting (TT)

Type Code	08	09	0A	0B	0C	0D
Min. Input	-10 V	-5 V	-1 V	-500 mV	-150 mV	-20 mA
Max Input	+10 V	+5 V	+1 V	+500 mV	+150 mV	+20 mA

Data Format Setting (FF)

7	6	5	4	3	2	1	0
*1	*2	*3	0	0	0	*4	

*1 :0 = 60Hz rejection

1 = 50Hz rejection

*2 :Checksum Bit : 0=Disable, 1=Enable

*3 :Fast/Normal Bit : 0=Normal, 1=Fast

(For I-7012F/12FD/17F only)

*4 :00 = Engineer Unit Format

01 = Percent Format

10 = 2's Complement HEX Format

Analog input type and data format table

Type Code	Input Range	Data Format	+F.S.	Zero	-F.S.
08	-10 to +10 V	Engineer Unit	+10.000	+00.000	-10.000
		% of FSR	+100.00	+000.00	-100.00
		2's complement HEX	7FFF	0000	8000
09	-5 to +5 V	Engineer Unit	+5.0000	+0.0000	-5.0000
		% of FSR	+100.00	+000.00	-100.00
		2's complement HEX	7FFF	0000	8000
0A	-1 to +1 V	Engineer Unit	+1.0000	+0.0000	-1.0000
		% of FSR	+100.00	+000.00	-100.00
		2's complement HEX	7FFF	0000	8000
0B	-500 to +500 mV	Engineer Unit	+500.00	+000.00	-500.00
		% of FSR	+100.00	+000.00	-100.00
		2's complement HEX	7FFF	0000	8000
0C	-150 to +150 mV	Engineer Unit	+150.00	+000.00	-150.00
		% of FSR	+100.00	+000.00	-100.00
		2's complement HEX	7FFF	0000	8000
0D	-20 to +20 mA	Engineer Unit	+20.000	+00.000	-20.000
		% of FSR	+100.00	+000.00	-100.00
		2's complement HEX	7FFF	0000	8000

2. Command

Command Format : **(Leading)(Address)(Command)[CHK](cr)**

Response Format : **(Leading)(Address)(Data)[CHK](cr)**

[CHK] 2-character checksum

(cr) end-of-command character, character return(0x0D)

Calculate Checksum :

1. Calculate ASCII sum of all characters of command(or response) string except the character return(cr).
2. Mask the sum of string with 0ffh.

Example :

Command string : \$012(cr)

Sum of string = '\$'+ '0'+ '1'+ '2' = 24h+30h+31h+32h = B7h

The checksum is B7h, and [CHK] = "B7"

Command string with checksum : \$012B7(cr)

Response string : !01070600(cr)

Sum of string : '!'+ '0'+ '1'+ '0'+ '7'+ '0'+ '6'+ '0'+ '0'

= 21h+30h+31h+30h+37h+30h+36h+30h+30h = 1AFh

The checksum is AFh, and [CHK] = "AF"

Response string with checksum : !01070600AF(cr)

General Command Sets			
Command	Response	Description	Section
%AANN TTCCFF	!AA	Set Module Configuration	<i>Sec.2.1</i>
##**	No Response	Synchronized Sampling	<i>Sec.2.2</i>
#AA	>(Data)	Read Analog Input	<i>Sec.2.3</i>
#AAN	>(Data)	Read Analog Input from channel N	<i>Sec.2.4</i>
\$AA0	!AA	Perform Span Calibration	<i>Sec.2.5</i>
\$AA1	!AA	Perform Zero Calibration	<i>Sec.2.6</i>
\$AA2	!AANN TTCCFF	Read Configuration	<i>Sec.2.7</i>
\$AA4	>AAS(Data)	Read Synchronized Data	<i>Sec.2.8</i>
\$AA5VV	!AA	Set Channel Enable	<i>Sec.2.9</i>
\$AA6	!AAVV	Read Channel Status	<i>Sec.2.10</i>
\$AA8	!AAV	Read LED Configuration	<i>Sec.2.11</i>
\$AA8V	!AA	Set LED Configuration	<i>Sec.2.12</i>
\$AA9(Data)	!AA	Set LED Data	<i>Sec.2.13</i>
\$AAA	!(Data)	Read 8 channel data	<i>Sec.2.14</i>
\$AAF	!AA(Data)	Read Firmware Version	<i>Sec.2.15</i>
\$AAM	!AA(Data)	Read Module Name	<i>Sec.2.16</i>
~AAO(Data)	!AA	Set Module Name	<i>Sec.2.17</i>
~AAEV	!AA	Enable/Disable Calibration	<i>Sec.2.18</i>

Digital Input/Output, Alarm and Event Counter Command Sets			
Command	Response	Description	Section
@AADI	!AASOOII	Read Digital I/O and Alarm Status	<i>Sec.2.19</i>
@AADO(Data)	!AA	Set Digital Output	<i>Sec.2.20</i>
@AAEAT	!AA	Enable Alarm	<i>Sec.2.21</i>
@AAHI(Data)	!AA	Set High Alarm	<i>Sec.2.22</i>
@AALO(Data)	!AA	Set Low Alarm	<i>Sec.2.23</i>
@AADA	!AA	Disable Alarm	<i>Sec.2.24</i>
@AACA	!AA	Clear Latch Alarm	<i>Sec.2.25</i>
@AARH	!AA(Data)	Read High Alarm	<i>Sec.2.26</i>
@AARL	!AA(Data)	Read Low Alarm	<i>Sec.2.27</i>
@AARE	!AA(Data)	Read Event Counter	<i>Sec.2.28</i>
@AACE	!AA	Clear Event Counter	<i>Sec.2.29</i>

Linear Mapping Command Sets			
Command	Response	Description	Section
\$AA3	!AA(SL)(SH)	Read Source Low/High Values for Linear Mapping	<i>Sec.2.30</i>
\$AA5	!AA(TL)(TH)	Read Target Low/High Values for Linear Mapping	<i>Sec.2.31</i>
\$AA6(SL)(SH)	!AA	Set Source Low/High Values for Linear Mapping	<i>Sec.2.32</i>
\$AA7(TL)(TH)	!AA	Set Target Low/High Values for Linear Mapping	<i>Sec.2.33</i>
\$AAA	!AAV	Read Linear Mapping Status	<i>Sec.2.34</i>
\$AAAV	!AA	Enable/Disable Linear Mapping	<i>Sec.2.35</i>

Host Watchdog Related Command Sets			
Command	Response	Description	Section
~**	No Response	Host OK	<i>Sec.2.36</i>
~AA0	!AASS	Read Module Status	<i>Sec.2.37</i>
~AA1	!AA	Reset Module Status	<i>Sec.2.38</i>
~AA2	!AAVV	Read Host Watchdog Timeout Interval	<i>Sec.2.39</i>
~AA3Evv	!AA	Set Host Watchdog Timeout Interval	<i>Sec.2.40</i>
~AA4	!AAPPSS	Read PowerOn Value and Safe Value	<i>Sec.2.41</i>
~AA5PPSS	!AA	Set PowerOn Value and Safe Value	<i>Sec.2.42</i>

2.1 %AANNTCCFF

Description : Set module Configuration

Syntax : %AANNTCCFF[CHK](cr)

% a delimiter character

AA address of setting module (00 to FF)

NN new address for setting module (00 to FF)

TT new type for setting module (Ref *Sec.1.10*)

CC new baudrate for setting module (Ref *Sec.1.10*). It is needed to short INIT* to ground while change baudrate. (Ref *Sec.3.1*)

FF new data format for setting module (Ref *Sec.1.10*). It is needed to short INIT* to ground while change checksum setting. (Ref *Sec.3.1*)

Response : Valid Command : !AA[CHK](cr)

Invalid Command : ?AA[CHK](cr)

Syntax error or communication error may get no response.

! delimiter for valid command

? delimiter for invalid command. While change baudrate or checksum setting without short INIT* to ground, the module will return invalid command.

AA address of response module (00 to FF)

Example :

Command : %0102080600 Receive : !02

Change address from 01 to 02, return success.

Command : %0202080602 Receive : !02

Change data format from 00 to 02, return success.

Related Command :

Sec.2.7 \$AA2

Related Topics :

Sec.1.10 Configuration Tables, Sec.3.1 INIT pin Operation*

2.2 #**

Description : Synchronized Sampling

Syntax : #**[CHK](cr)

a delimiter character

** synchronized sampling command

Response : No response

Example :

Command : #** No response

Send synchronized sampling command.

Command : \$014 Receive : >011+025.123

First read, get status=1.

Command : \$014 Receive : >010+025.123

Second read, get status=0.

Related Command :

Sec.2.8 \$AA4

Note : The command is for I-7012/12D/12F/12FD/14D only

2.4 #AAN

Description : Read Analog Input from channel N

Syntax : #AAN[CHK](cr)

delimiter character

AA address of reading module (00 to FF)

N channel to read, from 0 to 7

Response : Valid Command : >(Data)[CHK](cr)

Invalid Command : ?AA[CHK](cr)

Syntax error or communication error may get no response.

> delimiter for valid command

? delimiter for invalid command

AA address of response module (00 to FF)

(Data) analog input value, reference *Sec.1.10* for its format

Example :

Command : #032 Receive : >+02.513

Read address 03 channel 2, get data successfully.

Command : #029 Receive : ?02

Read address 02 channel 9, return error channel number.

Related Command :

Sec.2.1 %AANNTTCFF, *Sec.2.7* \$AA2

Related Topics :

Sec.1.10 Configuration Tables

Note : The command is for I-7017/17F only

2.5 \$AA0

Description : Perform Span Calibration

Syntax : \$AA0[CHK](cr)

\$ delimiter character

AA address of setting module (00 to FF)

0 command for performing span calibration

Response : Valid Command : !AA[CHK](cr)

Invalid Command : ?AA[CHK](cr)

Syntax error or communication error may get no response.

! delimiter for valid command

? delimiter for invalid command

AA address of response module (00 to FF)

Example :

Command : \$010 Receive : !01

Perform address 01 span calibration, return success.

Command : \$020 Receive : ?02

Perform address 02 span calibration, return not enable calibration before perform calibration command.

Related Command :

Sec.2.6 \$AA1, Sec.2.18 ~AAEV

Related Topics :

Sec.1.9 Calibration

2.6 \$AA1

Description : Perform Zero Calibration

Syntax : \$AA1[CHK](cr)

\$ delimiter character

AA address of setting module (00 to FF)

1 command for performing zero calibration

Response : Valid Command : !AA[CHK](cr)

Invalid Command : ?AA[CHK](cr)

Syntax error or communication error may get no response.

! delimiter for valid command

? delimiter for invalid command

AA address of response module (00 to FF)

Example :

Command : \$011 Receive : !01

Perform address 01 zero calibration, return success.

Command : \$021 Receive : ?02

Perform address 02 zero calibration, return not enable calibration before perform calibration command.

Related Command :

Sec.2.5 \$AA0, Sec.2.18 ~AAEV

Related Topics :

Sec.1.9 Calibration

2.7 \$AA2

Description : Read Configuration

Syntax : \$AA2[CHK](cr)

\$ delimiter character

AA address of reading module (00 to FF)

2 command for reading configuration

Response : Valid Command : !AATTCCFF[CHK](cr)

Invalid Command : ?AA[CHK](cr)

Syntax error or communication error may get no response.

! delimiter for valid command

? delimiter for invalid command

AA address of response module (00 to FF)

TT type code of module (reference *Sec.1.10*)

CC baudrate code of module (reference *Sec.1.10*)

FF data format of module (reference *Sec.1.10*)

Example :

Command : \$012 Receive : !01080600

Read address 01 configuration, return success.

Command : \$022 Receive : !020A0602

Read address 02 configuration, return success.

Related Command :

Sec.2.1 %AANNTTCCFF

Related Topics :

Sec.1.10 Configuration Tables, *Sec3.1* INIT* pin Operation

2.8 \$AA4

Description : Read Synchronized Data

Syntax : \$AA4[CHK](cr)

\$ delimiter character

AA address of reading module (00 to FF)

4 command for reading synchronized data

Response : Valid Command : >AAS(Data)[CHK](cr)

Invalid Command : ?AA[CHK](cr)

Syntax error or communication error may get no response.

! delimiter for valid command

? delimiter for invalid command

AA address of response module (00 to FF)

S status of synchronized data, 1 = first read, 0 = been readed

(Data) synchronized data, format reference *Sec.1.10*

Example :

Command : \$014 Receive : ?01

Read address 01 synchronized data, return no data valid.

Command : #** Receive : no response

Preform synchronized sampling

Command : \$014 Receive : >011+02.556

Read address 01 synchronized data, return status 1 and data.

Command : \$014 Receive : >010+02.556

Read address 01 synchronized data, return status 0 and data.

Related Command :

*Sec.2.2 #***

Note : The command is for I-7012/12D/12F/12FD/14D only

2.9 \$AA5VV

Description : Set Channel Enable

Syntax : \$AA5VV[CHK](cr)

\$ delimiter character

AA address of setting module (00 to FF)

5 command for set channel enable

VV channel enable/disable, 00 is all disabled and FF is all enabled.

Response : Valid Command : !AA[CHK](cr)

Invalid Command : ?AA[CHK](cr)

Syntax error or communication error may get no response.

! delimiter for valid command

? delimiter for invalid command

AA address of response module (00 to FF)

Example :

Command : \$0155A Receive : !01

Set address 01 to enable channel 1,3,4,6 and disable channel 0, 2,5,7, return success.

Command : \$016 Receive : !015A

Read address 01 channel status, return channel 1,3,4,6 are enabled and channel 0,2,5,7 are disabled.

Related Command :

Sec.2.10 \$AA6

Note : The command is for I-7017/17F only

2.10 \$AA6

Description : Read Channel Status

Syntax : \$AA6[CHK](cr)

\$ delimiter character

AA address of reading module (00 to FF)

6 command for read channel status

Response : Valid Command : !AAVV[CHK](cr)

Invalid Command : ?AA[CHK](cr)

Syntax error or communication error may get no response.

! delimiter for valid command

? delimiter for invalid command

AA address of response module (00 to FF)

VV channel enable/disable, 00 is all disabled and FF is all enabled.

Example :

Command : \$015A5 Receive : !01

Set address 01 to enable channel 0,2,5,7 and disable channel 1, 3,4,6, return success.

Command : \$016 Receive : !01A5

Read address 01 channel status, return channel 0,2,5,7 are enabled and channel 1,3,4,6 are disabled.

Related Command :

Sec.2.9 \$AA5VV

Note : The command is for I-7017/17F only

2.11 \$AA8

Description : Read LED Configuration

Syntax : \$AA8[CHK](cr)

\$ delimiter character

AA address of reading module (00 to FF)

8 command for reading LED configuration

Response : Valid Command : !AAV[CHK](cr)

Invalid Command : ?AA[CHK](cr)

Syntax error or communication error may get no response.

! delimiter for valid command

? delimiter for invalid command

AA address of response module (00 to FF)

V LED configuration

1=module control, 2=host control

Example :

Command : \$018 Receive : !011

Read address 01 LED configuration, return module control.

Command : \$028 Receive : !012

Read address 02 LED configuration, return host control.

Related Command :

Sec.2.12 \$AA8V, Sec.2.13 \$AA9(Data)

Note : The command is for I-7012D/12FD/14D only

2.12 \$AA8V

Description : Set LED Configuration

Syntax : \$AA8V[CHK](cr)

\$ delimiter character

AA address of setting module (00 to FF)

8 command for setting LED configuration

V 1=Set LED to module, 2=Set LED to host

Response : Valid Command : !AA[CHK](cr)

Invalid Command : ?AA[CHK](cr)

Syntax error or communication error may get no response.

! delimiter for valid command

? delimiter for invalid command

AA address of response module (00 to FF)

Example :

Command : \$0182 Receive : !01

Set address 01 LED to host control, return success.

Command : \$0281 Receive : !02

Set address 02 LED to module control, return success.

Related Command :

Sec.2.11 \$AA8, Sec.2.13 \$AA9(Data)

Note : The command is for I-7012D/12FD/14D only

2.13 \$AA9(Data)

Description : Set LED Data

Syntax : \$AA9(Data)[CHK](cr)

\$ delimiter character

AA address of setting module (00 to FF)

9 command for setting LED data

(Data) data for show on the LED, from -19999. to +19999. The data format is sign, 5 numeral and decimal point.

Response : Valid Command : !AA[CHK](cr)

Invalid Command : ?AA[CHK](cr)

Syntax error or communication error may get no response.

! delimiter for valid command

? delimiter for invalid command or LED not set to host control.

AA address of response module (00 to FF)

Example :

Command : \$019+123.45 Receive : !01

Send address 01 LED data +123.45, return success.

Command : \$029+512.34 Receive : ?02

Send address 02 LED data +512.34, return the LED is not setting in the host mode.

Related Command :

Sec.2.11 \$AA8, Sec.2.12 \$AA8V

Note : The command is for I-7012D/12FD/14D only

2.14 \$AAA

Description : Read 8 channel data

Syntax : \$AAA[CHK](cr)

\$ delimiter character

AA address of reading module (00 to FF)

A command for read 8 channel analog input data

Response : Valid Command : >(Data1)..(Data8)[CHK](cr)

Invalid Command : ?AA[CHK](cr)

Syntax error or communication error may get no response.

! delimiter for valid command

? delimiter for invalid command

AA address of response module (00 to FF)

(Data1)..(Data8) 8 channel analog input data, in format 2's complement HEX.

Example :

Command : \$01A

Receive : >0000012301257FFF1802744F98238124

Read address 01 8-channel analog input data, return success.

Related Command :

Sec.2.3 #AA

Note : The command is for I-7017/17F only

2.15 \$AAF

Description : Read Firmware Version

Syntax : \$AAF[CHK](cr)

\$ delimiter character

AA address of reading module (00 to FF)

F command for read firmware version

Response : Valid Command : !AA(Data)[CHK](cr)

Invalid Command : ?AA[CHK](cr)

Syntax error or communication error may get no response.

! delimiter for valid command

? delimiter for invalid command

AA address of response module (00 to FF)

(Data) firmware version of module

Example :

Command : \$01F Receive : !01A2.0

Read address 01 firmware version, return version A2.0.

Command : \$02F Receive : !01B1.1

Read address 02 firmware version, return version B1.1.

2.16 \$AAM

Description : Read Module Name

Syntax : \$AAM[CHK](cr)

\$ delimiter character

AA address of reading module (00 to FF)

M command for read module name

Response : Valid Command : !AA(Data)[CHK](cr)

Invalid Command : ?AA[CHK](cr)

Syntax error or communication error may get no response.

! delimiter for valid command

? delimiter for invalid command

AA address of response module (00 to FF)

(Data) Name of module

Example :

Command : \$01M Receive : !017012

Read address 01 module name, return name 7012.

Command : \$03M Receive : !037014D

Read address 03 module name, return name 7014D.

Related Command :

Sec.2.17 ~AAO(Data)

2.17 ~AAO(Data)

Description : Set Module Name

Syntax : ~AAO(Data)[CHK](cr)

~ delimiter character

AA address of setting module (00 to FF)

O command for set module name

(Data) new name for module, max 6 characters

Response : Valid Command : !AA[CHK](cr)

Invalid Command : ?AA[CHK](cr)

Syntax error or communication error may get no response.

! delimiter for valid command

? delimiter for invalid command

AA address of response module (00 to FF)

Example :

Command : ~01O7012 Receive : !01

Set address 01 module name to 7012, return success.

Command : \$01M Receive : !017012

Read address 01 module name, return 7012.

Related Command :

Sec.2.16 \$AAM

2.18 ~AAEV

Description : Enable/Disable Calibration

Syntax : ~AAEV[CHK](cr)

~ delimiter character

AA address of setting module (00 to FF)

E command for enable/disable calibration

V 1=Enable/0=Disable calibration

Response : Valid Command : !AA[CHK](cr)

Invalid Command : ?AA[CHK](cr)

Syntax error or communication error may get no response.

! delimiter for valid command

? delimiter for invalid command

AA address of response module (00 to FF)

Example :

Command : \$010 Receive : ?01

Perform address 01 span calibration, return the command is invalid before enable calibration.

Command : ~01E1 Receive : !01

Set address 01 to enable calibration, return success.

Command : \$010 Receive : !01

Perform address 01 span calibration, return success.

Related Command :

Sec.2.5 \$AA0, Sec.2.6 \$AA1

Related Topic :

Sec.1.9 Calibration

2.19 @AADI

Description : Read Digital I/O and Alarm Status

Syntax : @AADI[CHK](cr)

@ delimiter character

AA address of reading module (00 to FF)

DI command for reading digital input and alarm status

Response : Valid Command : !AASOOII[CHK](cr)

Invalid Command : ?AA[CHK](cr)

Syntax error or communication error may get no response.

! delimiter for valid command

? delimiter for invalid command

AA address of response module (00 to FF)

S alarm enable status, 0=alarm disable, 1=momentary alarm enabled, 2=latch alarm enabled.

OO digital output status, 00=DO0 off, DO1 off, 01=DO0 on, DO1 off, 02=DO0 off, DO1 on, 03=OD0 on, DO1 on.

II digital input status, 00=input low level, 01=input high level.

Example :

Command : @01DI Receive : !0100001

Read address 01 digital input, return alarm disable, digital output all off, and digital input high level.

Related Command :

Sec.2.20 @AADO(Data), Set.2.21 @AAEAT, Sec.2.24 @AADA

Related Topic :

Sec.3.4 Digital Input and Event Counter, Sec.3.5 Digital Output

Note : The command is for I-7012/12D/12F/12FD/14D only

2.20 @AADO(Data)

Description : Set Digital Output

Syntax : @AADO(Data)[CHK](cr)

@ delimiter character

AA address of setting module (00 to FF)

DO command for set digital output

(Data) output value, 00=DO0 off, DO1 off, 01=DO0 on, DO1 off, 02=DO0 off, DO1 on, 03=DO0 on, DO1 on

Response : Valid Command : !AA[CHK](cr)

Invalid Command : ?AA[CHK](cr)

Syntax error or communication error may get no response.

! delimiter for valid command

? delimiter for invalid command. While the alarm is enabled, the command will return invalid.

AA address of response module (00 to FF)

Example :

Command : @01DO00 Receive : !01

Set address 01 digital output 00, return success.

Related Command :

Sec.2.19 @AADI, Set.2.21 @AAEAT, Sec.2.24 @AADA

Related Topic :

Sec.3.5 Digital Output

Note : The command is for I-7012/12D/12F/12FD/14D only

2.21 @AAEAT

Description : Enable Alarm

Syntax : @AAEAT[CHK](cr)

@ delimiter character

AA address of setting module (00 to FF)

EA command for enable alarm.

T alarm type, M=momentary alarm, L=latch alarm.

Response : Valid Command : !AA[CHK](cr)

Invalid Command : ?AA[CHK](cr)

Syntax error or communication error may get no response.

! delimiter for valid command

? delimiter for invalid command

AA address of response module (00 to FF)

Example :

Command : @01EAM Receive : !01

Set address 01 momentary alarm, return success.

Related Command :

Sec.2.19 @AADI, Sec.2.24 @AADA, Sec.2.25 @AACA

Related Topic :

Sec.3.6 High/Low Alarm

Note : The command is for I-7012/12D/12F/12FD/14D only

2.22 @AAHI(Data)

Description : Set High Alarm

Syntax : @AAHI(Data)[CHK](cr)

@ delimiter character

AA address of setting module (00 to FF)

HI command for set high alarm value

(Data) high alarm values, data format is in engineer unit format.

Response : Valid Command : !AA[CHK](cr)

Invalid Command : ?AA[CHK](cr)

Syntax error or communication error may get no response.

! delimiter for valid command

? delimiter for invalid command

AA address of response module (00 to FF)

Example :

Command : @01HI+10.000 Receive : !01

Set address 01 high alarm +10.000, return success.

Related Command :

Sec.2.21 @AAEAT, Sec.2.26 @AARH

Related Topic :

Sec.3.6 High/Low Alarm

Note : The command is for I-7012/12D/12F/12FD/14D only

2.23 @AALO(Data)

Description : Set Low Alarm

Syntax : @AALO(Data)[CHK](cr)

@ delimiter character

AA address of setting module (00 to FF)

LO command for setting low alarm value

(Data) low alarm values, data format is in engineer unit format.

Response : Valid Command : !AA[CHK](cr)

Invalid Command : ?AA[CHK](cr)

Syntax error or communication error may get no response.

! delimiter for valid command

? delimiter for invalid command

AA address of response module (00 to FF)

Example :

Command : @01LO-10.000 Receive : !01

Set address 01 low alarm -10.000, return success.

Related Command :

Sec.2.21 @AAEAT, Sec.2.27 @AARL

Related Topic :

Sec.3.6 High/Low Alarm

Note : The command is for I-7012/12D/12F/12FD/14D only

2.24 @AADA

Description : Disable Alarm

Syntax : @AADA[CHK](cr)

@ delimiter character

AA address of setting module (00 to FF)

DA command for disable alarm

Response : Valid Command : !AA[CHK](cr)

Invalid Command : ?AA[CHK](cr)

Syntax error or communication error may get no response.

! delimiter for valid command

? delimiter for invalid command

AA address of response module (00 to FF)

Example :

Command : @01DA Receive : !01

Disable address 01 alarm, return success.

Related Command :

Sec.2.21 @AAEAT

Related Topic :

Sec.3.6 High/Low Alarm

Note : The command is for I-7012/12D/12F/12FD/14D only

2.25 @AACCA

Description : Clear Latch Alarm

Syntax : @AACCA[CHK](cr)

@ delimiter character

AA address of setting module (00 to FF)

CA command for clear latch alarm

Response : Valid Command : !AA[CHK](cr)

Invalid Command : ?AA[CHK](cr)

Syntax error or communication error may get no response.

! delimiter for valid command

? delimiter for invalid command

AA address of response module (00 to FF)

Example :

Command : @01DI Receive : !0120101

Read address 01 digital input, return latch alarm mode, low alarm active.

Command : @01CA Receive : !01

Clear address 01 latch alarm, return success.

Command : @01DI Receive : !0120001

Read address 01 digital input, return latch alarm mode, no alarm active.

Related Command :

Sec.2.19 @AADI, Sec.2.21 @AAEAT, Sec.2.24 @AADA

Related Topic :

Sec.3.6 High/Low Alarm

Note : The command is for I-7012/12D/12F/12FD/14D only

2.26 @AARH

Description : Read High Alarm

Syntax : @AARH[CHK](cr)

@ delimiter character

AA address of reading module (00 to FF)

RH command for reading high alarm

Response : Valid Command : !AA(Data)[CHK](cr)

Invalid Command : ?AA[CHK](cr)

Syntax error or communication error may get no response.

! delimiter for valid command.

? delimiter for invalid command.

AA address of response module (00 to FF)

(Data) high alarm value in engineer unit format.

Example :

Command : @01RH Receive : !01+10.000

Read address 01 high alarm, return +10.000.

Related Command :

Sec.2.22 @AAHI

Related Topic :

Sec.3.6 High/Low Alarm

Note : The command is for I-7012/12D/12F/12FD/14D only

2.27 @AARL

Description : Read Low Alarm

Syntax : @AARL[CHK](cr)

@ delimiter character

AA address of reading module (00 to FF)

RL command for reading low alarm

Response : Valid Command : !AA(Data)[CHK](cr)

Invalid Command : ?AA[CHK](cr)

Syntax error or communication error may get no response.

! delimiter for valid command.

? delimiter for invalid command.

AA address of response module (00 to FF)

(Data) low alarm value in engineer unit format.

Example :

Command : @01RL Receive : !01-10.000

Read address 01 low alarm, return -10.000.

Related Command :

Sec.2.23 @AALO

Related Topic :

Sec.3.6 High/Low Alarm

Note : The command is for I-7012/12D/12F/12FD/14D only

2.28 @AARE

Description : Read Event Counter

Syntax : @AARE[CHK](cr)

@ delimiter character

AA address of reading module (00 to FF)

RH command for reading event counter

Response : Valid Command : !AA(Data)[CHK](cr)

Invalid Command : ?AA[CHK](cr)

Syntax error or communication error may get no response.

! delimiter for valid command

? delimiter for invalid command

AA address of response module (00 to FF)

(Data) event counter value, from 00000 to 65535.

Example :

Command : @01RE Receive : !0101234

Read address 01 event counter, return 1234.

Related Command :

Sec.2.29 @AACE

Related Topic :

Sec.3.4 Digital Input and Event Counter

Note : The command is for I-7012/12D/12F/12FD/14D only

2.29 @AAACE

Description : Clear Event Counter

Syntax : @AAACE[CHK](cr)

@ delimiter character

AA address of setting module (00 to FF)

CE command for clear event counter

Response : Valid Command : !AA[CHK](cr)

Invalid Command : ?AA[CHK](cr)

Syntax error or communication error may get no response.

! delimiter for valid command

? delimiter for invalid command

AA address of response module (00 to FF)

Example :

Command : @01RE Receive : !0101234

Read address 01 event counter, return 1234.

Command : @01CE Receive : !01

Clear address 01 event counter, return success.

Command : @01RE Receive : !0100000

Read address 01 event counter, return 0.

Related Command :

Sec.2.28 @AARE

Related Topic :

Sec.3.4 Digital Input and Event Counter

Note : The command is for I-7012/12D/12F/12FD/14D only

2.31 \$AA5

Description : Read Target Low/High Values for Linear Mapping

Syntax : \$AA5[CHK](cr)

\$ delimiter character

AA address of reading module (00 to FF)

5 command for reading target values

Response : Valid Command : !AA(TL)(TH)[CHK](cr)

Invalid Command : ?AA[CHK](cr)

Syntax error or communication error may get no response.

! delimiter for valid command

? delimiter for invalid command

AA address of response module (00 to FF)

TL target low values in engineer unit format.

TH target high values in engineer unit format.

Example :

Command : \$015 Receive : !01-10.000+10.000

Read address 01 target value, return from -10 to +10.

Related Command :

Sec.2.30 \$AA3, Sec.2.32 \$AA6(SL)(SH), Sec.2.33 \$AA7(TL)(TH)

Related Topic :

Sec.3.8 Linear Mapping

Note : The command is for I-7014D only

2.32 \$AA6(SL)(SH)

Description : Set Source Low/High Values for Linear Mapping.
The data is stored into EEPROM after the command \$AA7(TL)(TH) applied.

Syntax : \$AA6(SL)(SH)[CHK](cr)

\$ delimiter character

AA address of setting module (00 to FF)

6 command for setting source values

SL source low level value in engineer unit format

SH source high level value in engineer unit format

Response : Valid Command : !AA[CHK](cr)

Invalid Command : ?AA[CHK](cr)

Syntax error or communication error may get no response.

! delimiter for valid command

? delimiter for invalid command

AA address of response module (00 to FF)

Example :

Command : \$016-10.000+10.000 Receive : !01

Set address 01 source value -10 to +10, return success.

Related Command :

Sec.2.30 \$AA3, Sec.2.31 \$AA5, Sec.2.33 \$AA7(TL)(TH)

Related Topic :

Sec.3.8 Linear Mapping

Note : The command is for I-7014D only

2.33 \$AA7(TL)(TH)

Description : Set Target Low/High Values for Linear Mapping

The command follows \$AA6(SL)(SH) command.

Syntax : \$AA7(TL)(TH)[CHK](cr)

\$ delimiter character

AA address of setting module (00 to FF)

7 command for setting target values

TL target low level value in engineer unit format

TH target high level value in engineer unit format

Response : Valid Command : !AA[CHK](cr)

Invalid Command : ?AA[CHK](cr)

Syntax error or communication error may get no response.

! delimiter for valid command

? delimiter for invalid command

AA address of response module (00 to FF)

Example :

Command : \$076-10.000+10.000 Receive : !01

Set address 01 target value -10 to +10, return success.

Related Command :

Sec.2.30 \$AA3, Sec.2.31 \$AA5, Sec.2.32 \$AA6(SL)(SH)

Related Topic :

Sec.3.8 Linear Mapping

Note : The command is for I-7014D only

2.34 \$AAA

Description : Read Linear Mapping Status

Syntax : \$AAA[CHK](cr)

\$ delimiter character

AA address of reading module (00 to FF)

A command for reading linear mapping status

Response : Valid Command : !AAV[CHK](cr)

Invalid Command : ?AA[CHK](cr)

Syntax error or communication error may get no response.

! delimiter for valid command

? delimiter for invalid command

AA address of response module (00 to FF)

V 0=disable linear mapping, 1=enable linear mapping

Example :

Command : \$01A Receive : !011

Read address 01 linear mapping status, return enable.

Related Command :

Sec.2.32 \$AA6(SL)(SH), Sec.2.33 \$AA7(TL)(TH)

Related Topic :

Sec.3.8 Linear Mapping

Note : The command is for I-7014D only

2.35 \$AAAV

Description : Enable/Disable Linear Mapping

Syntax : \$AAAV[CHK](cr)

\$ delimiter character

AA address of setting module (00 to FF)

A command for enable/disable linear mapping

V 0=disable linear mapping, 1=enable linear mapping

Response : Valid Command : !AA[CHK](cr)

Invalid Command : ?AA[CHK](cr)

Syntax error or communication error may get no response.

! delimiter for valid command

? delimiter for invalid command

AA address of response module (00 to FF)

Example :

Command : \$01A0 Receive : !01

Disable address 01 linear mapping, return success.

Related Command :

Sec.2.32 \$AA6(SL)(SH), Sec.2.33 \$AA7(TL)(TH)

Related Topic :

Sec.3.8 Linear Mapping

Note : The command is for I-7014D only

2.37 ~AA0

Description : Read Module Status

Syntax : ~AA0[CHK](cr)

~ delimiter character

AA address of reading module (00 to FF)

0 command for reading module status

Response : Valid Command : !AASS[CHK](cr)

Invalid Command : ?AA[CHK](cr)

Syntax error or communication error may get no response.

! delimiter for valid command

? delimiter for invalid command

AA address of response module (00 to FF)

SS module status, 00=host watchdog status is clear, 04=host watchdog status is set. The status will store into EEPROM and only may reset by the command ~AA1.

Example :

Command : ~010 Receive : !0100

Read address 01 module status, return 00.

Command : ~020 Receive : !0204

Read address 02 module status, return 04, means the host watchdog timeout status is set.

Related Command :

Sec.2.38 ~AA1, Sec.2.40 ~AA3EVV

Related Topic :

Set.3.2 Module Status, Sec.3.3 Dual Watchdog Operation

2.38 ~AA1

Description : Reset Module Status

Syntax : ~AA1[CHK](cr)

~ delimiter character

AA address of setting module (00 to FF)

1 command for reset module status

Response : Valid Command : !AA[CHK](cr)

Invalid Command : ?AA[CHK](cr)

Syntax error or communication error may get no response.

! delimiter for valid command

? delimiter for invalid command

AA address of response module (00 to FF)

Example :

Command : ~010 Receive : !0104

Read address 01 module status, return 04, host watchdog timeout status is set.

Command : ~011 Receive : !01

Reset address 01 module status, return success.

Command : ~010 Receive : !0100

Read address 01 module status, return 00, host watchdog timeout status is clear.

Related Command :

*Sec.2.36 ~**, Sec.2.37 ~AA0*

Related Topic :

Set.3.2 Module Status, Sec.3.3 Dual Watchdog Operation

2.39 ~AA2

Description : Read Host Watchdog Timeout Interval

Syntax : ~AA2[CHK](cr)

~ delimiter character

AA address of reading module (00 to FF)

2 command for reading host watchdog timeout interval

Response : Valid Command : !AAVV[CHK](cr)

Invalid Command : ?AA[CHK](cr)

Syntax error or communication error may get no response.

! delimiter for valid command

? delimiter for invalid command

AA address of response module (00 to FF)

VV timeout interval in HEX format, each count for 0.1 second,
01=0.1 second and FF=25.5 second

Example :

Command : ~012 Receive : !01FF

Read address 01 host watchdog timeout interval, return FF,
the host watchdog timeout interval is 25.5 second.

Related Command :

*Sec.2.36 ~**, Sec.2.40 ~AA3E VV*

Related Topic :

Set.3.2 Module Status, Sec.3.3 Dual Watchdog Operation

2.40 ~AA3E VV

Description : Set Host Watchdog Timeout Interval

Syntax : ~AA3E VV[CHK](cr)

~ delimiter character

AA address of setting module (00 to FF)

3 command for setting host watchdog timeout interval

E 1=Enable/0=Disable host watchdog

VV timeout interval, from 01 to FF, each for 0.1 second

Response : Valid Command : !AA[CHK](cr)

Invalid Command : ?AA[CHK](cr)

Syntax error or communication error may get no response.

! delimiter for valid command

? delimiter for invalid command

AA address of response module (00 to FF)

Example :

Command : ~013164 Receive : !01

Set address 01 enable host watchdog and timeout interval is 64 (10.0 second), return success.

Command : ~012 Receive : !0164

Read address 01 host watchdog timeout interval, return 64, the timeout interval is 10.0 second.

Related Command :

*Sec.2.36 ~**, Sec.2.39 ~AA2*

Related Topic :

Set.3.2 Module Status, Sec.3.3 Dual Watchdog Operation

2.41 ~AA4

Description : Read PowerOn Value and Safe Value

Syntax : ~AA4[CHK](cr)

~ delimiter character

AA address of reading module (00 to FF)

4 command for reading PowerOn Value and Safe Value

Response : Valid Command : !AAPPSS[CHK](cr)

Invalid Command : ?AA[CHK](cr)

Syntax error or communication error may get no response.

! delimiter for valid command

? delimiter for invalid command

AA address of response module (00 to FF)

PP PowerOn Value, 00=DO0 off, DO1 off, 01=DO0 on, DO1 off, 02=DO0 off, DO1 on, 03=DO0 on, DO1 on

SS Safe Value, 00=DO0 off, DO1 off, 01=DO0 on, DO1 off, 02=DO0 off, DO1 on, 03=DO0 on, DO1 on

Example :

Command : ~014 Receive : !010000

Read address 01 PowerOn/Safe Value, return PowerOn Value is DO0 off, DO1 off, Safe Value is DO0 off, DO1 off.

Related Command :

Sec.2.42 ~AA5PPSS

Related Topic :

Set.3.2 Module Status, Sec.3.3 Dual Watchdog Operation

Note : The command is for I-7012/12D/12F/12FD/14D only

2.42 ~AA5PPSS

Description : Set PowerOn Value and Safe Value

Syntax : ~AA5PPSS[CHK](cr)

~ delimiter character

AA address of setting module (00 to FF)

5 command for setting PowerOn Value and Safe Value

PP PowerOn Value, 00=DO0 off, DO1 off, 01=DO0 on, DO1 off, 02=DO0 off, DO1 on, 03=DO0 on, DO1 on

SS Safe Value, 00=DO0 off, DO1 off, 01=DO0 on, DO1 off, 02=DO0 off, DO1 on, 03=DO0 on, DO1 on

Response : Valid Command : !AA[CHK](cr)

Invalid Command : ?AA[CHK](cr)

Syntax error or communication error may get no response.

! delimiter for valid command

? delimiter for invalid command

AA address of response module (00 to FF)

Example :

Command : ~0150003 Receive : !01

Set address 01 PowerOn Value is DO0 off, DO1 off, Safe Value is DO0 on, DO1 on, return success.

Related Command :

Sec.2.41 ~AA4

Related Topic :

Set.3.2 Module Status, Sec.3.3 Dual Watchdog Operation

Note : The command is for I-7012/12D/12F/12FD/14D only

3. Application Note

3.1 INIT* pin Operation

Each I-7000 module has a build-in EEPROM to store configuration information such as address, type, baudrate and other information. Sometimes, user may forget the configuration of the module. Therefore, the I-7000 have a special mode named “**INIT mode**”, to help user to resolve the problem. The “**INIT mode**” is setting as **Address=00, baudrate=9600bps, no checksum**

To enable INIT mode, please follow these steps:

Step1. Power off the module

Step2. Connect the INIT* pin with the GND pin.

Step3. Power on

Step4. Send command \$002(cr) in 9600bps to read the configuration stored in the module’s EEPROM.

Refer to “**7000 Bus Converter User Manual**” *Sec.5.1* and “**Getting Start**” for more information.

3.2 Module Status

PowerOn Reset or **Module Watchdog Reset** will let all output goto **PowerOn Value**. And the module may accept the host’s command to change the output value.

Host Watchdog Timeout will let all digital output goto **Safe Value**.The module’s status (readed by command ~AA0) will be 04, and the output command will be ignored.

3.3 Dual Watchdog Operation

Dual Watchdog = Module Watchdog + Host Watchdog

The Module Watchdog is a hardware reset circuit to monitor the module's operation status. When working in harsh or noisy environment, the module may be down by the external signal. The circuit may let the module to work continuously and never halt.

The Host Watchdog is a software function to monitor the host's operation status. Its purpose is to prevent from the network/communication problem or host halt. While the timeout interval expired, the module will turn the all output to safe state to prevent from unexpected problem of controlled target.

The I-7000 module with Dual Watchdog may let the control system more reliable and stable.

3.4 Digital Input and Event Counter

The digital input DI0 may work as event counter. The counter updates while the input changes from high level to low level. The counter is 16-bit width and useful for low speed count, frequency is lower than 50Hz.

3.5 Digital Output

When the module power on, the host watchdog timeout status is checked first. If the status is set, the digital outputs (DO0 and DO1) of module will set to Safe Value. If the status is clear, the digital outputs will set to PowerOn Value.

If the host watchdog timeout status is set, the module will ignore the digital output command @AADO(Data).

3.6 High/Low Alarm

Some analog input modules, like I-7012, equip with the high/low alarm function. When the alarm function is enabled, the digital output DO0 is the low alarm indicator, DO1 is the high alarm indicator, and the digital output command to change the DO0 and DO1 is ignored. The alarm function is to compare the analog input value with given high alarm value and low alarm value. There are two alarm types as follows :

- **Momentary Alarm** : the alarm status is cleared while the analog input is not exceed the alarm value.

If Analog Input Value $>$ High Alarm, DO1(High alarm) is on, else DO1 is off.

If Analog Input Value $<$ Low Alarm, DO0(Low alarm) is on, else DO0 is off.

- **Latch Alarm** : the alarm is cleared only the user send command to clear.

If Analog Input Value $>$ High Alarm, DO1(High alarm) is on, else if Analog Input Value $<$ Low Alarm, DO0(Low alarm) is on.

3.7 Transmitter

Transmitter is an instrument to convert the signal from the sensor to 4-20mA or 0-5V signal level. Transmitters may support driving or compensation circuit for sensor, and the output is after linearization and amplification.

2-wire transmitter, typical 4 to 20mA current output signal.

One for power input, the other is signal output.

3-wire transmitters, typical 0 to 5V voltage output signal.

One pair for power input and ground and the other is signal output.

3.8 Linear Mapping

Linear mapping function is to translate the input value to the desired output value. The linear mapping is a mechanism that convert the analog input value into physical quantity.

Linear mapping have some values to given : mapping source low value (SL) to target low value(TL), source high value (SH) to target high value(TH). For input value(AI), the output value is :

if $AI < SL$, output value = -19999. (under limit)

else if $AI > SH$, output value = +19999. (over limit)

else output value = $(AI-SL)/(SH-SL) * (TH-TL) + TL$

For example, if we connect a temperature sensor to I-7014D, and the sensor output is 4mA while the temperature is 0 degree Celsius, 20mA while the temperature is 100 degree Celsius. We want to read the temperature directly. We have the source values, 4 to 20mA, and target values, 0 to 100 degree Celsius. Suppose the I-7014D is address 01, and baud 9600 bps, no-checksum.

1. Set the I-7014D to read ± 20 mA type.

Command : `%01010D0600`

Receive : `!01`

(Ref *Sec.2.1* %AANN TTCCFF)

2. Set the source low value(SL)=4 and source high value(SH)=20.

Command : `$016+04.000+20.000`

Receive : `!01`

(Ref *Sec.2.32* ~AA6(SL)(SH))

3. Set the target low value(TL)=0 and target high value(TH)=100.

Command : $\$017+000.00+100.00$ Receive : *!01*

(Ref *Sec.2.33* \$AA7(TL)(TH))

4. Enable linear mapping function.

Command : $\$01A1$ Receive : *!01*

(Ref *Sec.2.34* \$AAAV)

Then we'll get the temperature value from I-7014D directly for command #AA.